

General Specifications

EJA118E Diaphragm Sealed Differential Pressure Transmitter



GS 01C31H01-01EN

Diaphragm seals are used to prevent process medium from entering directly into the pressure-sensing assembly of the differential pressure transmitter, they are connected to the transmitter using capillaries filled with fill fluid.

EJA118E Diaphragm Sealed Differential Pressure Transmitters can be used to measure liquid, gas, or steam flow, as well as liquid level, density, and pressure. EJA118E outputs a 4 to 20 mA DC signal corresponding to the measured differential pressure.

Its highly accurate and stable sensor can also measure the static pressure which can be shown on the integral indicator or remotely monitored via BRAIN or HART communications. Other key features include quick response, remote set-up using communications, and self-diagnostics.

FOUNDATION Fieldbus, PROFIBUS PA and 1 to 5 V DC with HART (Low Power) protocol types are also available. All EJA-E series models in their standard configuration, with the exception of the Fieldbus, PROFIBUS and Low Power types, are certified as complying with SIL 2 for safety requirement.



■ STANDARD SPECIFICATIONS

Refer to GS 01C31T02-01EN for Fieldbus communication type and GS 01C31T04-01EN for PROFIBUS PA communication type for the items marked with “◇.”

□ SPAN AND RANGE LIMITS

Measurement Span/Range	kPa	inH ₂ O (/D1)	mbar (/D3)	mmH ₂ O (/D4)	
M	Span	2.5 to 100	10 to 400	25 to 1000	
	Range	-100 to 100	-400 to 400	-1000 to 1000	-10000 to 10000
H	Span	25 to 500	100 to 2000	250 to 5000	0.25 to 5 kgf/cm ²
	Range	-500 to 500	-2000 to 2000	-5000 to 5000	-5 to 5 kgf/cm ²

□ PERFORMANCE SPECIFICATIONS

Zero-based calibrated span, linear output, wetted parts material code SW for 3-inch flange flush type, fill fluid code B, and capillary length of 5 m. For Fieldbus and PROFIBUS communication types, use caribrated range instead of span in the following specifications.

Specification Conformance

EJA-E series ensures specification conformance to at least $\pm 3\sigma$.

Reference Accuracy of Calibrated Span (includes terminal-based linearity, hysteresis, and repeatability)

Measurement span	H
Reference accuracy X ≤ span	±0.2% of Span
X > span	±(0.15+0.01 URL/span)% of Span
X	100 kPa (400 inH ₂ O)
URL (upper range limit)	500 kPa (2000 inH ₂ O)

Measurement span	M
Reference accuracy X ≤ span	±0.2% of Span
X > span	±(0.15+0.01 URL/span)% of Span
X	20 kPa (80 inH ₂ O)
URL (upper range limit)	100 kPa (400 inH ₂ O)

Square Root Output Accuracy

The square root accuracy is a percent of flow span.

Output	Accuracy
50% or Greater	Same as reference accuracy
50% to Dropout point	$\frac{\text{Reference accuracy} \times 50}{\text{Square root output}} (\%)$

Ambient Temperature Effects per 28°C (50°F) Change

Capsule	Effect
M and H	±(0.48% Span+0.06% URL)

Static Pressure Effects per 0.69 MPa (100 psi) Change**Span Effects**M and H capsules

±0.02% of span

Effect on ZeroM and H capsules

±0.014% of URL

Power Supply Effects(Output signal code D and J)

±0.005 % per Volt (from 21.6 to 32 V DC, 350Ω)

Response Time (Differential pressure) “◇”

M and H capsule: 200 ms (approximate value at normal temperature)

When software damping is set to zero and including dead time of 45 ms (nominal)

Static Pressure Signal Range and Accuracy (For monitoring via communication or on indicator. Includes terminal-based linearity, hysteresis, and repeatability)**Range**

Upper Range Value and Lower Range Value of the static pressure can be set in the range between 0 and Maximum Working Pressure (MWP*). The upper range value must be greater than the lower range value. Minimum setting span is 0.5 MPa (73 psi).

*: Maximum Working Pressure (MWP) is within flange rating pressure.

AccuracyAbsolute Pressure

1 MPa or higher: ±0.5% of span

Less than 1 MPa: ±0.5%×(1 MPa/span) of span

Gauge Pressure Reference

Gauge pressure reference is 1013 hPa (1 atm)

Note: Gauge pressure variable is based on the above fixed reference and thus subject to be affected by the change of atmospheric pressure.

□ **FUNCTIONAL SPECIFICATIONS****Output “◇”****For 4 to 20 mA HART / BRAIN****(Output signal code D and J)**

Two wire 4 to 20 mA DC output with digital communications, linear or square root programmable. BRAIN or HART FSK protocol are superimposed on the 4 to 20 mA signal.

Output range: 3.6 mA to 21.6 mA

Output limits conform to NAMUR NE43 can be preset by option code C2 or C3.

For 1 to 5 V HART (Output signal code Q)

Three or four wire low power 1 to 5 V DC output with HART, linear or square root programmable. HART protocol are superimposed on the 1 to 5 V DC signal. Output range: 0.9 V to 5.4 V DC

Failure Alarm**For 4 to 20 mA HART / BRAIN****(Output signal code D and J)**

Output status at CPU failure and hardware error;

Up-scale: 110%, 21.6 mA DC or more (standard)

Down-scale: -5%, 3.2 mA DC or less

For 1 to 5 V HART (Output signal code Q)

Analog output status at CPU failure and hardware error;

Up-scale: 110%, 5.4 V DC or more (standard)

Down-scale: -5%, 0.8 V DC or less

Damping Time Constant (1st order)

Amplifier damping time constant is adjustable from 0.00 to 100.00 s by software and added to response time.

Note: For BRAIN protocol type, when amplifier software damping is set to less than 0.5 s, communication may occasionally be unavailable during the operation, especially while output changes dynamically. The default setting of damping ensures stable communication.

Update Period “◇”

Differential pressure: 45 ms

Static pressure: 360 ms

Zero Adjustment Limits

Zero can be fully elevated or suppressed, within the lower and upper range limits of the capsule.

External Zero Adjustment

External zero is continuously adjustable with 0.01% incremental resolution of span. Re-range can be done locally using the digital indicator with rangesetting switch.

Integral Indicator (LCD display, optional) “◇”

5-digit numerical display, 6-digit unit display and bar graph.

The indicator is configurable to display one or up to four of the following variables periodically.; Measured differential pressure, differential pressure in %, scaled differential pressure, measured static pressure. See also “Factory Setting.”

Local Parameter Setting**(Output signal code D, J and Q)**

Parameter configuration by the external zero adjustment screw and push button (Integral indicator code E) offers easy and quick setup for parameters of Tag number, Unit, LRV, URV, Damping, Output mode (linear/square root), Display out 1, and Re-range by applying actual pressure (LRV/URV).

Self Diagnostics

CPU failure, hardware failure, configuration error, process alarm for differential pressure, static pressure or capsule temperature.

User-configurable process high/low alarm for differential pressure and static pressure is also available.

Signal Characterizer**(Output signal code D, J and Q)**

User-configurable 10-segment signal characterizer for 4 to 20 mA output.

Capillary Fill Fluid Density Compensation**(Output signal code D, J and Q)**

Compensation of the zero shift by the ambient temperature effect on the capillary tube.

SIL Certification

EJA-E series transmitters except Fieldbus and PROFIBUS PA and 1-5V DC with HART (Low Power) communication types are certified in compliance with the following standards; IEC 61508: 2000; Part1 to Part 7 Functional Safety of Electrical/electronic/programmable electronic related systems; SIL 2 capability for single transmitter use, SIL 3 capability for dual transmitter use.

□ **NORMAL OPERATING CONDITION**
(Optional features or approval codes may affect limits.)

Ambient Temperature Limits

- 40 to 60°C (-40 to 140°F)
- 30 to 60°C (-22 to 140°F) with LCD display
(Note: The ambient temperature limits must be within the fill fluid operating temperature range, see table 1.)

Process Temperature Limits

See table 1.

Ambient Humidity Limits

0 to 100% RH

Working Pressure Limits

See table 1.
For atmospheric pressure or below, see figure 1-1, 1-2, 1-3, 1-4, and 1-5.

Supply & Load Requirements

(Output signal code D and J. Optional features or approval codes may affect electrical requirements.)

With 24 V DC supply, up to a 550Ω load can be used. See figure 2.

Supply Voltage “◇”

For 4 to 20 mA HART / BRAIN

(Output signal code D and J)

- 10.5 to 42 V DC for general use and flameproof type.
- 10.5 to 32 V DC for lightning protector
(option code /A.)
- 10.5 to 30 V DC for intrinsically safe, type n, or non-incendive.

Minimum voltage limited at 16.6 V DC for digital communications, BRAIN and HART

For 1 to 5 V HART (Output signal code Q)

- Power supply :
9 to 28 V DC for general use and flame proof type.
- Power Consumption :
0.96 mA to 3 mA, 27 mW

Load for 4 to 20 mA HART / BRAIN

(Output signal code D and J)

- 0 to 1290Ω for operation
- 250 to 600Ω for digital communication

Output Load for 1 to 5 V HART

(Output signal code Q)

- 1 MΩ or greater (meter input impedance)
- Note that with three-wire connection, the cable length may affect the measurement accuracy of the output signal.

Communication Requirements “◇”

(Approval codes may affect electrical requirements.)

BRAIN

Communication Distance

Up to 2 km (1.25 miles) when using CEV polyethylene-insulated PVC-sheathed cables. Communication distance varies depending on type of cable used.

Load Capacitance

0.22 μF or less

Load Inductance

3.3 mH or less

Input Impedance of communicating device

10 kΩ or more at 2.4 kHz.

EMC Conformity Standards

- EN 61326-1 Class A, Table2 (For use in industrial locations)
- EN 61326-2-3
- EN 61326-2-5 (for fieldbus)

European Pressure Equipment Directive 97/23/EC (until 18th July, 2016)

2014/68/EU (from 19th July, 2016)
Sound Engineering Practice

Safety Requirement Standards

- EN 61010-1, EN 61010-2-030
- C22.2 No.61010-1, C22.2 No.61010-2-030
- Altitude of installation site: Max. 2,000 m above sea level
- Installation category: I
(Anticipated transient overvoltage 330 V)
- Pollution degree: 2
- Indoor/Outdoor use

Table 1. Process temperature, Ambient temperature, and Working pressure

	Code	Process temperature*1	Ambient temperature*2	Working pressure	Specific gravity*3
Silicone oil (general use)	A	-10 to 250°C *4 (14 to 482°F)	-10 to 60°C (14 to 140°F)	2.7 kPa abs (0.38 psi abs) to flange rating pressure	1.07
Silicone oil (general use)	B	-30 to 180°C (-22 to 356°F)	-15 to 60°C (5 to 140°F)		0.94
Silicone oil (high temperature use)	C	10 to 310°C (50 to 590°F)	10 to 60°C (50 to 140°F)		1.09
Fluorinated oil (oil-prohibited use)	D	-20 to 120°C (-4 to 248°F)	-10 to 60°C (14 to 140°F)	51 kPa abs (7.4 psi abs) to flange rating pressure	1.90 to 1.92
Ethylene glycol (low temperature use)	E	-50 to 100°C (-58 to 212°F)	-40 to 60°C (-40 to 140°F)	100 kPa abs (atmospheric pressure) to flange pressure rating	1.09
Silicone oil (high temp. and high vacuum use)	1	-10 to 250°C *4 (14 to 482°F)	-10 to 60°C *5 (14 to 140°F)	0.013 kPa abs (0.0019 psi abs) to flange rating pressure	1.07
Silicone oil (high temp. and high vacuum use)	2	10 to 310°C (50 to 590°F)	10 to 60°C *5 (50 to 140°F)		1.09
Silicone oil (high vacuum use)	4	-10 to 100°C (14 to 212°F)	-10 to 60°C *5 (14 to 140°F)		1.07

*1: See figure 1-1, 1-2, 1-3, 1-4, and 1-5 'Working Pressure and Process Temperature.'

*2: This ambient temperature is the transmitter ambient temperature.

*3: Approximate values at a temperature of 25°C (77°F)

*4: In case of wetted parts material code TW (Tantalum), process temperature limit is up to 200°C (392°F).

*5: The upper ambient temperature limit is 50°(122°F) in the following combinations.

Process connection style code	Process connection size code
W (Flush type)	2 (2-inch) or 8 (1 1/2-inch)
E (Extension type)	3 (3-inch)

Note: The differential pressure transmitter should be installed at least 600 mm below the high pressure (HP) process connection. However, this value (600 mm) may be affected by ambient temperature, operating pressure, fill fluid or material of the wetted diaphragm.

Contact YOKOGAWA when the transmitter can not be installed at least 600 mm below the HP process connection.

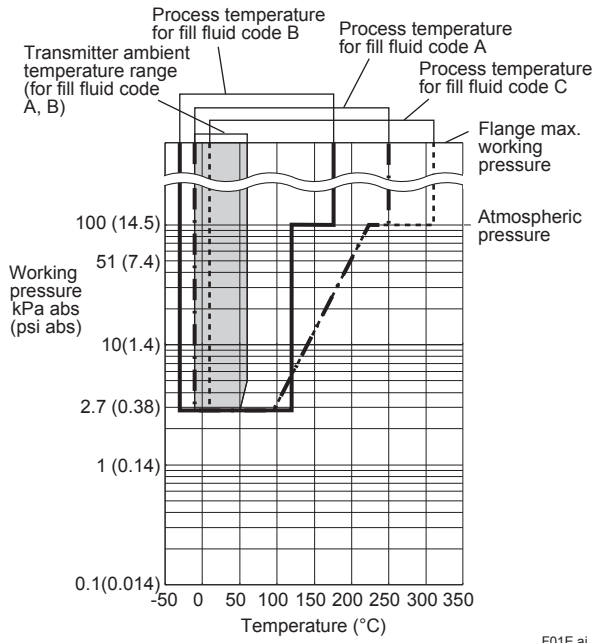

F01E.ai

Figure 1-1. Working Pressure and Process Temperature (Fill fluid: silicone oil for general and high temperature use)

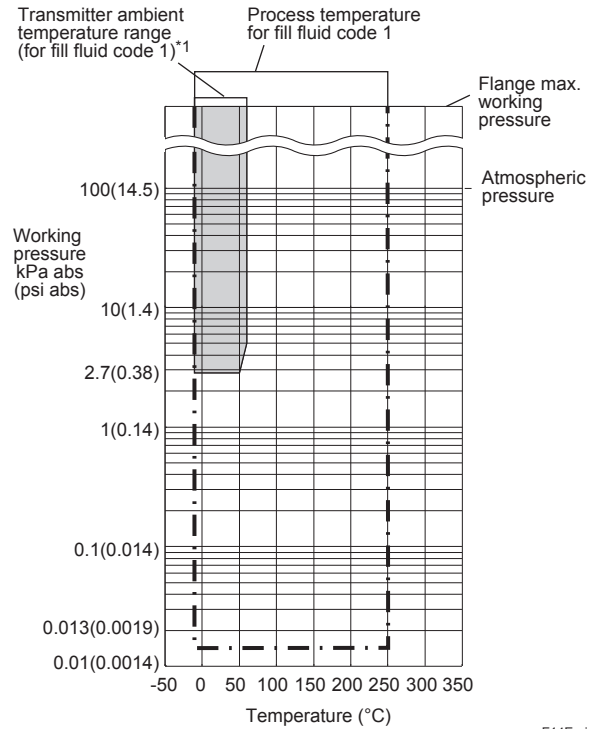

F14E.ai

Figure 1-3. Working Pressure and Process Temperature (Fill fluid: silicone oil for high temp. and high vacuum use)

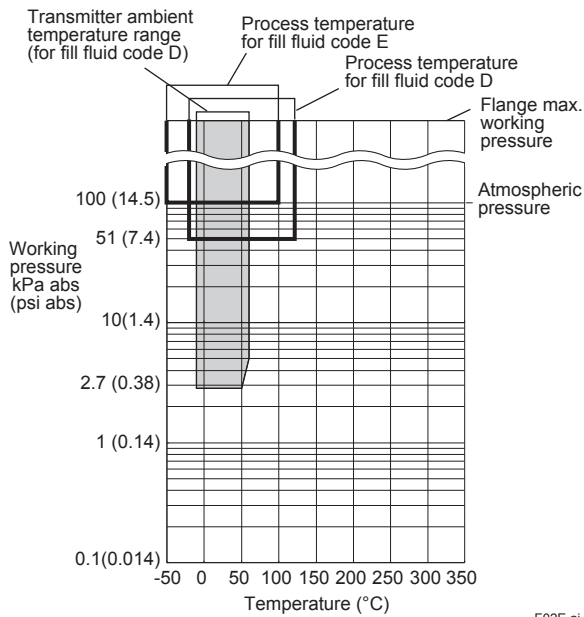

F02E.ai

Figure 1-2. Working Pressure and Process Temperature (Fill fluid: fluorinated oil for oil-prohibited use and ethylene glycol for low temperature use)

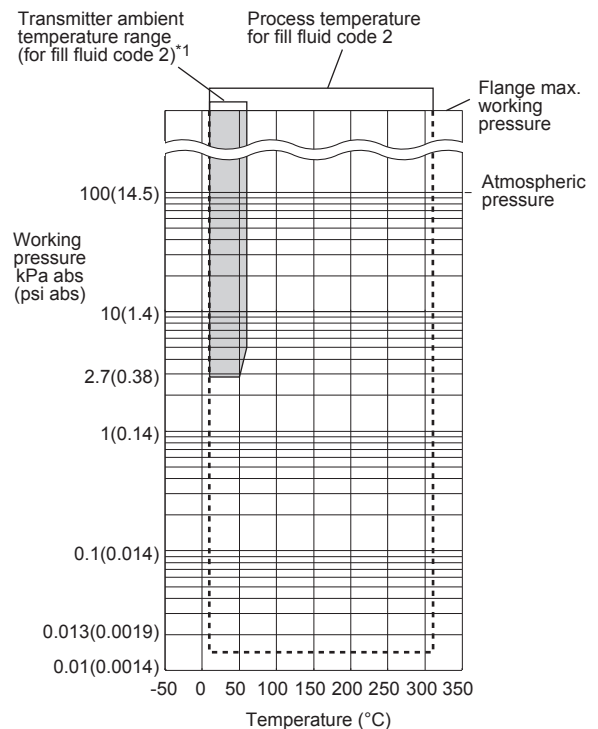

F15E.ai

Figure 1-4. Working Pressure and Process Temperature (Fill fluid: silicone oil for high temp. and high vacuum use)

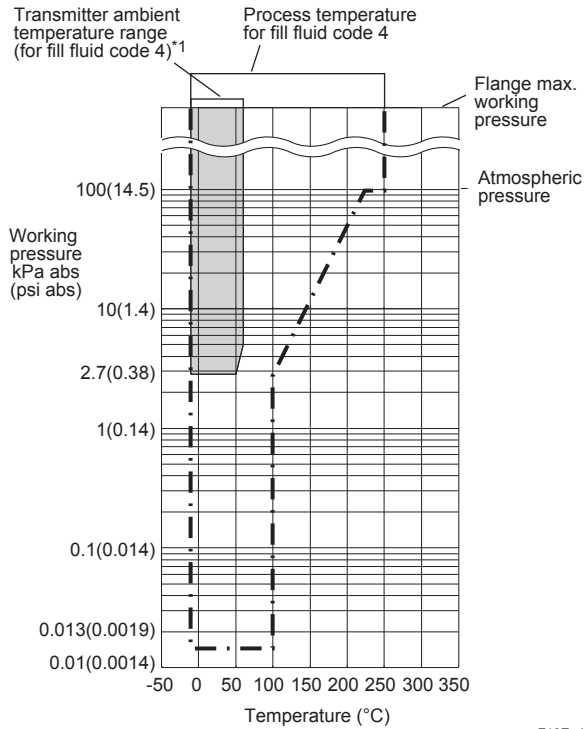

Figure 1-5. Working Pressure and Process Temperature (Fill fluid: silicone oil for high vacuum use)

*1: The upper ambient temperature limit is 50°(122°F) in the following combinations.

Process connection style code	Process connection size code
W (Flush type)	2 (2-inch) or 8 (1 1/2-inch)
E (Extension type)	3 (3-inch)

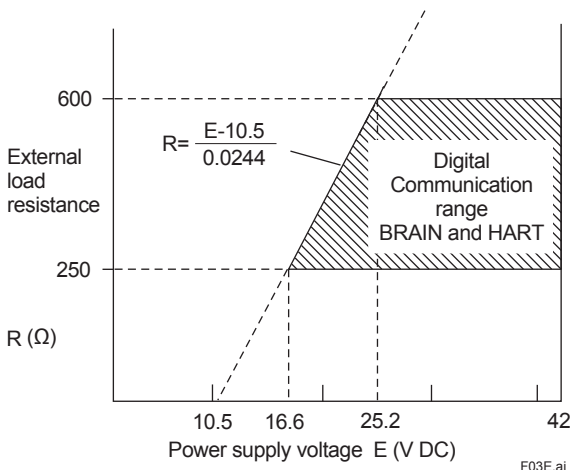

Figure 2. Relationship Between Power Supply Voltage and External Load Resistance (Output signal code D and J)

□ **PHYSICAL SPECIFICATIONS**

Process connections

See the following table.

Table 2. Flange size and rating

Process connection style	Size	Flange
Flush type	3-inch 2-inch 1 1/2-inch*	JIS 10K, 20K, 40K ANSI Class 150, 300, 600 JPI Class 150, 300, 600 DIN PN10/16, 25/40, 64
Extended type	4-inch 3-inch	JIS 10K, 20K ANSI Class 150, 300 JPI Class 150, 300 DIN PN10/16, 25/40
Combination type (Extended and Flush)	High pressure side: 4-inch Low pressure side: 3-inch	JIS 10K, 20K ANSI Class 150, 300 JPI Class 150, 300 DIN PN10/16, 25/40

* : Flushing connection rings are always attached.

Gasket Contact Surface

See the following table.

Table 3. Gasket contact surface

	Flange	JIS/JPI/DIN		ANSI	
		SW, SE, SY	HW, TW, UW	SW, SE, SY	HW, TW, UW
Wetted parts material code					
Gasket contact Surface	Serration*1	—	—	●	—
	Flat (No serration)	●	●	●	●

● : Applicable
— : Not applicable
*1: ANSI B16.5

Electrical Connections

See "MODEL AND SUFFIX CODES."

Transmitter Mounting

2-inch pipe mounting

Wetted Parts Materials

Diaphragm seal

Diaphragm and other wetted parts;
Refer to "MODEL AND SUFFIX CODES."

Flushing connection ring (optional)

Ring and Vent / Drain plugs
Refer to "MODEL AND SUFFIX CODES."
(Spiral) gasket for transmitter side
316SST (Hoop), PTFE Teflon (Filler)

Non-wetted Parts Materials

Transmitter body section:

Cover flange
ASTM CF-8M
Cover flange bolting
B7 carbon steel, 316L SST or 660 SST

Housing
Low copper cast aluminum alloy with polyurethane, deep sea moss green paint (Munsell 0.6GY3.1/2.0 or its equivalent) or ASTM CF-8M stainless steel

Degrees of Protection
IP66/IP67, Type 4X

Cover O-rings
Buna-N, fluoro-rubber (optional)

Name plate and tag
316 SST

Diaphragm seal section:

Process Flange

JIS S25C, JIS SUS304, or JIS SUS316

Capillary tube

JIS SUS316

Protection tube

JIS SUS304 PVC-sheathed
(Max. operating temperature of PVC, 100°C (212°F))

Fill fluid

See table 1.

Weight

Flush type: 16.1 kg (35.5 lbs)
(3-inch ANSI Class150 flange, capillary length 5 m;
without integral indicator and mounting bracket.)
Extended type: 21.7 kg (47.9 lbs)
(4-inch ANSI Class150 flange, extension length
(X₂)=100 mm, capillary length 5 m; without integral
indicator and mounting bracket.)
Combination type: 18.9 kg (41.7 lbs)
(4-inch and 3-inch ANSI Class150 flange, extension
length (X₂) =100 mm, capillary length 5 m; without
integral indicator and mounting bracket.)

Add 1.5kg (3.3lb) for Amplifier housing code 2.

< Related Instruments > “◇”

Power Distributor: Refer to GS 01B04T01-02E or
GS 01B04T02-02E
BRAIN TERMINAL: Refer to GS 01C00A11-00E

< Reference >

- *DPHarp EJA* is a registered trademark of Yokogawa Electric Corporation.
 - FieldMate; Trademark of Yokogawa Electric Corporation.
 - Teflon; Trademark of E.I. DuPont de Nemours & Co.
 - Hastelloy; Trademark of Haynes International Inc.
 - HART; Trademark of the HART Communication Foundation.
 - FOUNDATION Fieldbus; Trademark of Fieldbus Foundation.
 - PROFIBUS; Registered trademark of Profibus Nutzerorganisation e.v., Karlsruhe, Germany.
- Other company names and product names used in this material are registered trademarks or trademarks of their respective owners.

■ MODEL AND SUFFIX CODES

● Instruction

The model and suffix codes for EJA118E consist of two parts; a transmitter body section (I) and a diaphragm seal section (II). This specification sheet introduces these two parts separately. The transmitter body section is shown in one table, and the diaphragm seal section specifications are listed according to the process connection style.

First select the model and suffix codes of transmitter body section and then continue on one of the diaphragm seal section.

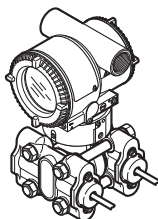
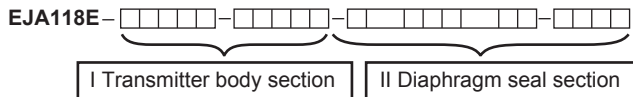

See Page 8

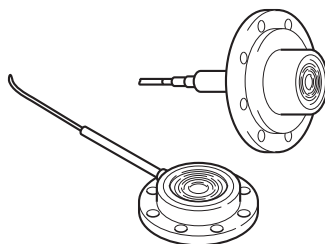

Flush type

- Flange size: 3-inch, 2-inch ••• See Page 9
- Flange size: 1 1/2-inch ••• See Page 11
- Extended type ••• See Page 12
- Combination type ••• See Page 14

F04E.ai

I. Transmitter body section

EJA118E-

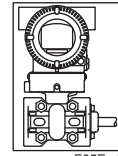

F05E.ai

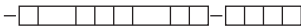
Model	Suffix Codes	Description		
EJA118E	Diaphragm sealed differential pressure transmitter		
Output signal	-D -J -F -G -Q	4 to 20 mA DC with digital communication (BRAIN protocol) 4 to 20 mA DC with digital communication (HART 5/HART 7 protocol)*1 Digital communication (FOUNDATION Fieldbus protocol, refer to GS 01C31T02-01EN) Digital communication (PROFIBUS PA protocol, refer to GS 01C31T04-01EN) Low Power, 1 to 5 V DC with digital communication (HART 7 protocol)*7		
Measurement span (capsule)	M H	2.5 to 100 kPa (10 to 400 inH ₂ O) 25 to 500 kPa (100 to 2000 inH ₂ O)		
	S	Always S		
	C	Always C		
Coverflange bolts and nuts material	J G C	B7 carbon steel 316L SST 660 SST		
Installation	-9	Horizontal piping type and left side high pressure		
Amplifier housing	1 3 2	Cast aluminum alloy Cast aluminum alloy with corrosion resistance properties*2 ASTM CF-8M stainless steel*3		
	Electrical connection	0 2 4 5 7 9 A C D	G 1/2 female, one electrical connection without blind plugs 1/2 NPT female, two electrical connections without blind plugs M20 female, two electrical connections without blind plugs G 1/2 female, two electrical connections with a blind plug *4 1/2 NPT female, two electrical connections with a blind plug *4 M20 female, two electrical connections with a blind plug *4 G1/2 female, two electrical connections and a 316 SST blind plug 1/2 NPT female, two electrical connections and a 316 SST blind plug M20 female, two electrical connections and a 316 SST blind plug	
		Integral indicator	D E N	Digital indicator*5 Digital indicator with the range setting switch (push button)*6 None
Mounting bracket			B J N	304 SST 2-inch pipe mounting, flat type (for horizontal piping) 316 SST 2-inch pipe mounting, flat type (for horizontal piping) None
			Diaphragm seal section	-  Continued on diaphragm seal section (II)

The "▶" marks indicate the most typical selection for each specification.
 *1: HART 5 or HART 7 is selectable. Specify upon ordering.
 *2: Not applicable for electrical connection code 0, 5, 7, 9 and A. Content rate of copper in the material is 0.03% or less and content rate of iron is 0.15% or less.
 *3: Not applicable for electrical connection code 0, 5, 7 and 9.
 *4: Material of a blind plug is aluminum alloy or 304 SST
 *5: Not applicable for output signal code G.
 *6: Not applicable for output signal code F.
 *7: As CE marking is still pending, not applicable for those countries which require CE marking.

II. Diaphragm seal section (Flush type)

- Process connection size: 3-inch (80mm) / 2-inch (50mm)

EJA118E-□□□□□□-□□□□□□-W 3 2 □□□□□□□□□□□□

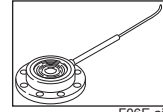

F06E.ai

Model	Suffix codes	Description																		
EJA118E	-□□□□□□-□□□□□□	Transmitter body section (I)																		
Process connection style	-W.....	Flush type																		
Flange rating	J1..... JIS 10K J2..... JIS 20K J4..... JIS 40K A1..... ANSI class 150 A2..... ANSI class 300 A4..... ANSI class 600 D2..... DIN PN10/16 D4..... DIN PN25/40 D5..... DIN PN64 P1..... JPI class 150 P2..... JPI class 300 P4..... JPI class 600																			
Process connection size (Process flange size)	3..... 3-inch (80 mm) 2..... 2-inch (50 mm)																			
Flange material	▶ A..... JIS S25C B..... 304 SST *11 C..... 316 SST *11																			
Gasket contact surface*1	1..... Serration (for ANSI flange with wetted parts material SW only) 2..... Flat (no serration)																			
Wetted parts material*10	<table border="0"> <tr> <td>SW.....</td> <td>[Diaphragm]</td> <td>[Others]</td> </tr> <tr> <td>HW.....</td> <td>316L SST</td> <td>316L SST</td> </tr> <tr> <td>TW.....</td> <td>Hastelloy C-276*9#</td> <td>Hastelloy C-276*9#</td> </tr> <tr> <td>UW.....</td> <td>Tantalum *7</td> <td>Tantalum *7</td> </tr> <tr> <td></td> <td>Titanium</td> <td>Titanium (for 3-inch process flange only)</td> </tr> </table>	SW.....	[Diaphragm]	[Others]	HW.....	316L SST	316L SST	TW.....	Hastelloy C-276*9#	Hastelloy C-276*9#	UW.....	Tantalum *7	Tantalum *7		Titanium	Titanium (for 3-inch process flange only)				
SW.....	[Diaphragm]	[Others]																		
HW.....	316L SST	316L SST																		
TW.....	Hastelloy C-276*9#	Hastelloy C-276*9#																		
UW.....	Tantalum *7	Tantalum *7																		
	Titanium	Titanium (for 3-inch process flange only)																		
Flushing connection ring*2	▶ 0..... [Ring] None 1..... Straight type 2..... Straight type	<table border="0"> <tr> <th>[Vent/Drain plugs]</th> <th>[Material]</th> </tr> <tr> <td>—</td> <td>—</td> </tr> <tr> <td>R 1/4 connections</td> <td>316 SST #</td> </tr> <tr> <td>1/4 NPT connections</td> <td>316 SST #</td> </tr> </table>	[Vent/Drain plugs]	[Material]	—	—	R 1/4 connections	316 SST #	1/4 NPT connections	316 SST #										
[Vent/Drain plugs]	[Material]																			
—	—																			
R 1/4 connections	316 SST #																			
1/4 NPT connections	316 SST #																			
Extension	0.....	None																		
Fill fluid*5	▶ -A..... For general use (silicone oil) ³ -B..... For general use (silicone oil) -C..... For high temperature use (silicone oil) ^{4*7} -D..... For oil-prohibited use (fluorinated oil) ⁵ -E..... For low temperature use (ethylene glycol) -1..... High temp. and high vacuum use (Silicone oil) ^{3*12} -2..... High temp. and high vacuum use (Silicone oil) ^{4*7*12} -4..... High vacuum use (Silicone oil) ¹²	<table border="0"> <tr> <th>[Process temperature]</th> <th>[Ambient temperature]</th> </tr> <tr> <td>-10 to 250°C</td> <td>-10 to 60°C</td> </tr> <tr> <td>-30 to 180°C</td> <td>-15 to 60°C</td> </tr> <tr> <td>10 to 310°C</td> <td>10 to 60°C</td> </tr> <tr> <td>-20 to 120°C</td> <td>-10 to 60°C</td> </tr> <tr> <td>-50 to 100°C</td> <td>-40 to 60°C</td> </tr> <tr> <td>-10 to 250°C</td> <td>-10 to 60°C(50°C)¹³</td> </tr> <tr> <td>10 to 310°C</td> <td>10 to 60°C(50°C)¹³</td> </tr> <tr> <td>-10 to 100°C</td> <td>-10 to 60°C(50°C)¹³</td> </tr> </table>	[Process temperature]	[Ambient temperature]	-10 to 250°C	-10 to 60°C	-30 to 180°C	-15 to 60°C	10 to 310°C	10 to 60°C	-20 to 120°C	-10 to 60°C	-50 to 100°C	-40 to 60°C	-10 to 250°C	-10 to 60°C(50°C) ¹³	10 to 310°C	10 to 60°C(50°C) ¹³	-10 to 100°C	-10 to 60°C(50°C) ¹³
[Process temperature]	[Ambient temperature]																			
-10 to 250°C	-10 to 60°C																			
-30 to 180°C	-15 to 60°C																			
10 to 310°C	10 to 60°C																			
-20 to 120°C	-10 to 60°C																			
-50 to 100°C	-40 to 60°C																			
-10 to 250°C	-10 to 60°C(50°C) ¹³																			
10 to 310°C	10 to 60°C(50°C) ¹³																			
-10 to 100°C	-10 to 60°C(50°C) ¹³																			
Capillary connection	A.....	Side of diaphragm seal unit																		
—	2.....	Always 2																		
Capillary length*6	1... 1 m 2... 2 m 3... 3 m 4... 4 m 5... 5 m	6..... 6 m 7..... 7 m 8..... 8 m 9..... 9 m A..... 10 m																		
Option codes		/□ Optional specification																		

The “▶” marks indicate the most typical selection for each specification.
 Example: EJA118E-DMSCG-912EN-WA13B1SW00-BA25/□

-
- *1: See table 3 'Gasket contact surface' on page 6.
 - *2: When specified flushing connection ring code 1 or 2, exclusive gaskets are provided for transmitter side.
 - *3: In case of wetted parts material code TW (Tantalum), the process temperature limit is -10 to 200°C.
 - *4: Wetted parts material code TW (Tantalum) cannot be applied.
 - *5: Even in case where fill fluid code D (fluorinated oil) is selected, if degrease cleansing treatment or both degrease cleansing and dehydrating treatment for the wetted parts is required, specify option code K1 or K5.
 - *6: In case of wetted parts material code HW (Hastelloy C) and TW (Tantalum) for 2-inch process flange, specify capillary length from 1 to 5m.
 - *7: Not applicable for flashing connection ring code 1 and 2.
 - *8: Not applicable for gasket contact surface code 1.
 - *9: Hastelloy C-276 or N10276.
 - *10: Δ Users must consider the characteristics of selected wetted parts material and the influence of process fluids. The use of inappropriate materials can result in the leakage of corrosive process fluids and cause injury to personnel and/or damage to plant facilities. It is also possible that the diaphragm itself can be damaged and that material from the broken diaphragm and the fill fluid can contaminate the user's process fluids.
Be very careful with highly corrosive process fluids such as hydrochloric acid, sulfuric acid, hydrogen sulfide, sodium hypochlorite, and hightemperature steam (150°C [302°F] or above). Contact Yokogawa for detailed information of the wetted parts material.
 - *11: Forged version of the material may be used.
 - *12: Not applicable for wetted parts material code UW.
 - *13: The upper ambient temperature limit is 50°(122°F) when specifying process connection size code 2 (2-inch).
- The #marks indicate the construction materials conform to NACE material recommendations per MR0175/ISO 15156. Please refer to the latest standards for details. Selected materials also conform to NACE MR0103.

II. Diaphragm seal section (Flush type)

● Process connection size: 1 1/2-inch (40 mm)

EJA118E-□□□□-□□□□-W 8 □□□□□□□□□□

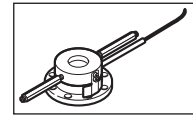

F07E.ai

Model	Suffix codes	Description
EJA118E	-□□□□□□-□□□□□□	Transmitter body section (I)
Process connection style	-W.....	Flush type
Flange rating	J1..... J2..... J4..... A1..... A2..... A4..... P1..... P2..... P4.....	JIS 10K JIS 20K JIS 40K ANSI class 150 ANSI class 300 ANSI class 600 JPI class 150 JPI class 300 JPI class 600
Process connection size (Process flange size)	8.....	1 1/2-inch (40 mm)
Flange material	▶ A..... B..... C.....	JIS S25C 304 SST *6 316 SST *6
Gasket contact surface*1	1..... 2.....	Serration (for ANSI flange only) Flat (no serration)
Wetted parts material*5	SW.....	[Diaphragm] 316L SST [Others] 316L SST
Flushing connection ring*2	3..... 4.....	[Ring] Reducer type [Vent/Drain plugs] R 1/4 connections*4 [Material] 316 SST # [Ring] Reducer type [Vent/Drain plugs] 1/4 NPT connections [Material] 316 SST #
Extension	0.....	None
Fill fluid	▶ -A..... -B..... -D..... -E..... -1..... -4.....	[Process temperature] [Ambient temperature] For general use (silicone oil) -10 to 250°C -10 to 60°C For general use (silicone oil) -30 to 180°C -15 to 60°C For oil-prohibited use (fluorinated oil)*3 -20 to 120°C -10 to 60°C For low temperature use (ethylene glycol) -50 to 100°C -40 to 60°C High temp. and high vacuum use (Silicone oil) -10 to 250°C -10 to 50°C High vacuum use (Silicone oil) -10 to 100°C -10 to 50°C
Capillary connection	A.....	Side of diaphragm seal unit
—	2.....	Always 2
Capillary length	1... 2... 3... 4... 5... 6... 7... 8... 9... A...	1 m 2 m 3 m 4 m 5 m 6 m 7 m 8 m 9 m 10 m
Option codes		/□ Optional specification

The “▶” marks indicate the most typical selection for each specification.

Example: EJA118E-DMSCG-912EN-WA18B1SW40-BA25/□

*1: See table 3 'Gasket contact surface' on page 6.

*2: When specified flushing connection ring code 3 or 4, exclusive gaskets are provided for transmitter side.

*3: Even in case where fill fluid code D (fluorinated oil) is selected, if degrease cleansing treatment or both degrease cleansing and dehydrating treatment for the wetted parts is required, specify option code K1 or K5.

*4: Not applicable for gasket contact surface code 1.

*5: ⚠ Users must consider the characteristics of selected wetted parts material and the influence of process fluids. The use of inappropriate materials can result in the leakage of corrosive process fluids and cause injury to personnel and/or damage to plant facilities. It is also possible that the diaphragm itself can be damaged and that material from the broken diaphragm and the fill fluid can contaminate the user's process fluids.

Be very careful with highly corrosive process fluids such as hydrochloric acid, sulfuric acid, hydrogen sulfide, sodium hypochlorite, and hightemperature steam (150°C [302°F] or above). Contact Yokogawa for detailed information of the wetted parts material.

*6: Forged version of the material may be used.

II. Diaphragm seal section (Extended type)

- Process connection size: 4-inch (100 mm) / 3-inch (80 mm)

EJA118E-□□□□-□□□□-E $\frac{4}{3}$ □□□□-□□□□

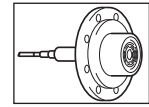

F08E.ai

Model	Suffix codes	Description																											
EJA118E	-□□□□-□□□□	Transmitter body section (I)																											
Process connection style	-E	Extended type																											
Flange rating	J1 J2 A1 A2 P1 P2 D2 D4	JIS 10K JIS 20K ANSI class 150 ANSI class 300 JPI class 150 JPI class 300 DIN PN10/16 DIN PN25/40																											
Process connection size (Process flange size)	4 3	4-inch (100 mm) 3-inch (80 mm)																											
Flange material	▶ A B C	JIS S25C 304 SST *5 316 SST *5																											
Gasket contact surface*1	1 2	Serration (for ANSI flange only) Flat (no serration)																											
Wetted parts material*4	SE.....	[Diaphragm] [Pipe] [Others] 316L SST 316 SST 316 SST																											
Flushing connection ring	0	None																											
Extension	2 4 6	Length (X2) = 50 mm Length (X2) = 100 mm Length (X2) = 150 mm																											
Fill fluid	▶ -A -B -C -D -E -1 -2 -4	<table border="0"> <tr> <td></td> <td>[Process temperature]</td> <td>[Ambient temperature]</td> </tr> <tr> <td>-A</td> <td>For general use (silicone oil) -10 to 250°C</td> <td>-10 to 60°C</td> </tr> <tr> <td>-B</td> <td>For general use (silicone oil) -30 to 180°C</td> <td>-15 to 60°C</td> </tr> <tr> <td>-C</td> <td>For high temperature use (silicone oil) 10 to 310°C</td> <td>10 to 60°C</td> </tr> <tr> <td>-D</td> <td>For oil-prohibited use (fluorinated oil)*2 -20 to 120°C</td> <td>-10 to 60°C</td> </tr> <tr> <td>-E</td> <td>For low temperature use (ethylene glycol) -50 to 100°C</td> <td>-40 to 60°C</td> </tr> <tr> <td>-1</td> <td>High temp. and high vacuum use (Silicone oil) -10 to 250°C</td> <td>-10 to 60°C(50°C)*6</td> </tr> <tr> <td>-2</td> <td>High temp. and high vacuum use (Silicone oil) 10 to 310°C</td> <td>10 to 60°C(50°C)*6</td> </tr> <tr> <td>-4</td> <td>High vacuum use (Silicone oil) -10 to 100°C</td> <td>-10 to 60°C(50°C)*6</td> </tr> </table>		[Process temperature]	[Ambient temperature]	-A	For general use (silicone oil) -10 to 250°C	-10 to 60°C	-B	For general use (silicone oil) -30 to 180°C	-15 to 60°C	-C	For high temperature use (silicone oil) 10 to 310°C	10 to 60°C	-D	For oil-prohibited use (fluorinated oil)*2 -20 to 120°C	-10 to 60°C	-E	For low temperature use (ethylene glycol) -50 to 100°C	-40 to 60°C	-1	High temp. and high vacuum use (Silicone oil) -10 to 250°C	-10 to 60°C(50°C)*6	-2	High temp. and high vacuum use (Silicone oil) 10 to 310°C	10 to 60°C(50°C)*6	-4	High vacuum use (Silicone oil) -10 to 100°C	-10 to 60°C(50°C)*6
	[Process temperature]	[Ambient temperature]																											
-A	For general use (silicone oil) -10 to 250°C	-10 to 60°C																											
-B	For general use (silicone oil) -30 to 180°C	-15 to 60°C																											
-C	For high temperature use (silicone oil) 10 to 310°C	10 to 60°C																											
-D	For oil-prohibited use (fluorinated oil)*2 -20 to 120°C	-10 to 60°C																											
-E	For low temperature use (ethylene glycol) -50 to 100°C	-40 to 60°C																											
-1	High temp. and high vacuum use (Silicone oil) -10 to 250°C	-10 to 60°C(50°C)*6																											
-2	High temp. and high vacuum use (Silicone oil) 10 to 310°C	10 to 60°C(50°C)*6																											
-4	High vacuum use (Silicone oil) -10 to 100°C	-10 to 60°C(50°C)*6																											
Capillary connection	B.....	Back of diaphragm seal unit																											
—	2.....	Always 2																											
Capillary length*3	1... 2... 3... 4... 5...	6 6 m 7 7 m 8 8 m 9 9 m A 10 m																											
Option codes		/□ Optional specification																											

The “▶” marks indicate the most typical selection for each specification.

Example: EJA118E-DMSCG-912EN-EA14B1SE02-BB25/□

*1: See table 3 ‘Gasket contact surface’ on page 6.

*2: Even in case where fill fluid code D (fluorinated oil) is selected, if degrease cleansing treatment or both degrease cleansing and dehydrating treatment for the wetted parts is required, specify option code K1 or K5.

*3: The specified capillary length includes the extension length (X2) and the flange thickness (t).

-
- *4: ⚠ Users must consider the characteristics of selected wetted parts material and the influence of process fluids. The use of inappropriate materials can result in the leakage of corrosive process fluids and cause injury to personnel and/or damage to plant facilities. It is also possible that the diaphragm itself can be damaged and that material from the broken diaphragm and the fill fluid can contaminate the user's process fluids.
Be very careful with highly corrosive process fluids such as hydrochloric acid, sulfuric acid, hydrogen sulfide, sodium hypochlorite, and hightemperature steam (150°C [302°F] or above). Contact Yokogawa for detailed information of the wetted parts material.
 - *5: Forged version of the material may be used.
 - *6: The upper ambient temperature limit is 50°(122°F) when specifying process connection size code 3 (3-inch).

II. Diaphragm seal section (Combination type)

- Process connection size: High pressure side; 4-inch (100 mm) • • • Extended type
Low pressure side; 3-inch (80 mm) • • • Flush type

EJA118E-□□□□□□-□□□□□□-Y □ W □□□□□□□□□□

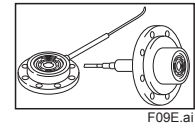

Model	Suffix codes	Description																											
EJA118E	-□□□□□□-□□□□□□	Transmitter body section (I)																											
Process connection style	-Y	Combination type (Extended and Flush)																											
Flange rating	J1 J2 A1 A2 P1 P2 D2 D4	JIS 10K JIS 20K ANSI class 150 ANSI class 300 JPI class 150 JPI class 300 DIN PN10/16 DIN PN25/40																											
Process connection size (Process flange size)	W	High pressure side 4-inch (100 mm) Low pressure side 3-inch (80 mm)																											
Flange material	▶ A B C	JIS S25C 304 SST *5 316 SST *5																											
Gasket contact surface*1	1 2	Serration (for ANSI flange only) Flat (no serration)																											
Wetted parts material*4	SY	<table border="0"> <tr> <td></td> <td>[Diaphragm]</td> <td>[Pipe]</td> <td>[Others]</td> </tr> <tr> <td>High pressure side:</td> <td>316L SST</td> <td>316 SST</td> <td>316 SST</td> </tr> <tr> <td>Low pressure side:</td> <td>316L SST</td> <td>—</td> <td>316L SST</td> </tr> </table>		[Diaphragm]	[Pipe]	[Others]	High pressure side:	316L SST	316 SST	316 SST	Low pressure side:	316L SST	—	316L SST															
	[Diaphragm]	[Pipe]	[Others]																										
High pressure side:	316L SST	316 SST	316 SST																										
Low pressure side:	316L SST	—	316L SST																										
Flushing connection ring	0	None																											
Extension	1 3 5	Length (X2) = 50 mm Length (X2) = 100 mm Length (X2) = 150 mm																											
Fill fluid	▶ -A -B -C -D -E -1 -2 -4	<table border="0"> <tr> <td></td> <td>[Process temperature]</td> <td>[Ambient temperature]</td> </tr> <tr> <td>-A</td> <td>For general use (silicone oil) -10 to 250°C</td> <td>-10 to 60°C</td> </tr> <tr> <td>-B</td> <td>For general use (silicone oil) -30 to 180°C</td> <td>-15 to 60°C</td> </tr> <tr> <td>-C</td> <td>For high temperature use (silicone oil) 10 to 310°C</td> <td>10 to 60°C</td> </tr> <tr> <td>-D</td> <td>For oil-prohibited use (fluorinated oil)*2 -20 to 120°C</td> <td>-10 to 60°C</td> </tr> <tr> <td>-E</td> <td>For low temperature use (ethylene glycol) -50 to 100°C</td> <td>-40 to 60°C</td> </tr> <tr> <td>-1</td> <td>High temp. and high vacuum use (Silicone oil) -10 to 250°C</td> <td>-10 to 60°C</td> </tr> <tr> <td>-2</td> <td>High temp. and high vacuum use (Silicone oil) 10 to 310°C</td> <td>10 to 60°C</td> </tr> <tr> <td>-4</td> <td>High vacuum use (Silicone oil) -10 to 100°C</td> <td>-10 to 60°C</td> </tr> </table>		[Process temperature]	[Ambient temperature]	-A	For general use (silicone oil) -10 to 250°C	-10 to 60°C	-B	For general use (silicone oil) -30 to 180°C	-15 to 60°C	-C	For high temperature use (silicone oil) 10 to 310°C	10 to 60°C	-D	For oil-prohibited use (fluorinated oil)*2 -20 to 120°C	-10 to 60°C	-E	For low temperature use (ethylene glycol) -50 to 100°C	-40 to 60°C	-1	High temp. and high vacuum use (Silicone oil) -10 to 250°C	-10 to 60°C	-2	High temp. and high vacuum use (Silicone oil) 10 to 310°C	10 to 60°C	-4	High vacuum use (Silicone oil) -10 to 100°C	-10 to 60°C
	[Process temperature]	[Ambient temperature]																											
-A	For general use (silicone oil) -10 to 250°C	-10 to 60°C																											
-B	For general use (silicone oil) -30 to 180°C	-15 to 60°C																											
-C	For high temperature use (silicone oil) 10 to 310°C	10 to 60°C																											
-D	For oil-prohibited use (fluorinated oil)*2 -20 to 120°C	-10 to 60°C																											
-E	For low temperature use (ethylene glycol) -50 to 100°C	-40 to 60°C																											
-1	High temp. and high vacuum use (Silicone oil) -10 to 250°C	-10 to 60°C																											
-2	High temp. and high vacuum use (Silicone oil) 10 to 310°C	10 to 60°C																											
-4	High vacuum use (Silicone oil) -10 to 100°C	-10 to 60°C																											
Capillary connection	C	High pressure side: Back of diaphragm seal unit Low pressure side: Side of diaphragm seal unit																											
—	2	Always 2																											
Capillary length*3	1 ... 2 ... 3 ... 4 ... 5 ...	6 6 m 7 7 m 8 8 m 9 9 m A 10 m																											
Option codes		/□ Optional specification																											

The “▶” marks indicate the most typical selection for each specification.

Example: EJA118E-DMSCG-912EN-YA1WB1SY01-BC25/□

*1: See table 3 'Gasket contact surface' on page 6.

*2: Even in case where fill fluid code D (fluorinated oil) is selected, if degrease cleansing treatment or both degrease cleansing and dehydrating treatment for the wetted parts is required, specify option code K1 or K5.

*3: The specified capillary length of high pressure side (extended side) includes the extension length (X2) and the flange thickness (t).

-
- *4: ⚠ Users must consider the characteristics of selected wetted parts material and the influence of process fluids. The use of inappropriate materials can result in the leakage of corrosive process fluids and cause injury to personnel and/or damage to plant facilities. It is also possible that the diaphragm itself can be damaged and that material from the broken diaphragm and the fill fluid can contaminate the user's process fluids.
Be very careful with highly corrosive process fluids such as hydrochloric acid, sulfuric acid, hydrogen sulfide, sodium hypochlorite, and hightemperature steam (150°C [302°F] or above). Contact Yokogawa for detailed information of the wetted parts material.
- *5: Forged version of the material may be used.

■ OPTIONAL SPECIFICATIONS (For Explosion Protected type) “◇”

For other agency approvals and marine approvals, please refer to GS 01C25A20-01EN.

Item	Description	Code
Factory Mutual (FM)	FM Explosionproof Approval ^{**1} Applicable Standard: FM3600, FM3615, FM3810, ANSI/NEMA 250 Explosionproof for Class I, Division 1, Groups B, C and D, Dust-ignitionproof for Class II/III, Division 1, Groups E, F and G, in Hazardous locations, indoors and outdoors (Enclosure: Type 4X) “FACTORY SEALED, CONDUIT SEAL NOT REQUIRED.” Temperature class: T6, Amb. Temp.: -40 to 60°C (-40 to 140°F)	FF1
	FM Intrinsically safe Approval ^{**1,3} Applicable Standard: FM3600, FM3610, FM3611, FM3810 Intrinsically Safe for Class I, Division 1, Groups A, B, C & D, Class II, Division 1, Groups E, F & G and Class III, Division 1, Class I, Zone 0, in Hazardous Locations, AEx ia IIC Nonincendive for Class I, Division 2, Groups A, B, C & D, Class II, Division. 2, Groups F & G, Class I, Zone 2, Group IIC, in Hazardous Locations Enclosure: Type 4X, Temp. Class: T4, Amb. Temp.: -60 to 60°C (-75 to 140°F) Intrinsically Safe Apparatus Parameters [Groups A, B, C, D, E, F and G] Vmax=30 V, Imax=200 mA, Pmax=1 W, Ci=6 nF, Li=0 μH [Groups C, D, E, F and G] Vmax=30 V, Imax=225 mA, Pmax=1 W, Ci=6 nF, Li=0 μH	FS1
	Combined FF1 and FS1 ^{**1,3}	FU1
ATEX	ATEX Flameproof Approval ^{**1,3} Applicable Standard: EN 60079-0:2012/A11:2013, EN 60079-1:2007, EN 60079-31:2009 Certificate: KEMA 07ATEX0109 X II 2G, 2D Ex d IIC T6...T4 Gb, Ex tb IIIC T85°C Db Degree of protection: IP66/IP67 Amb. Temp. (Tamb) for gas-proof: T4; -50 to 75°C (-58 to 167°F), T5; -50 to 80°C (-58 to 176°F), T6; -50 to 75°C (-58 to 167°F) Process Temp. for gas-proof (Tp): T4; -50 to 120°C (-58 to 248°F), T5; -50 to 100°C (-58 to 212°F), T6; -50 to 85°C (-58 to 185°F) Max. surface Temp. for dust-proof: T85°C (Tamb: -30 to 75°C, Tp: -30 to 85°C) ^{**2}	KF22
	ATEX Intrinsically safe Approval ^{**1,3} Applicable Standard: EN 60079-0:2012/A11:2013, EN 60079-11:2012, EN 60079-26:2007 Certificate: DEKRA 11ATEX0228 X II 1G, 2D Ex ia IIC T4 Ga, Ex ia IIIC T85°C T100°C T120°C Db Degree of protection: IP66/IP67 Amb. Temp. (Tamb) for EPL Ga: -50 to 60°C (-58 to 140°F) Maximum Process Temp. (Tp) for EPL Ga: 120°C Electrical data: Ui=30 V, Ii=200 mA, Pi=0.9 W, Ci=27.6 nF, Li=0 μH Amb. Temp. for EPL Db: -30 to 60°C ^{**2} Max. surface Temp. for EPL Db: T85°C (Tp: 80°C), T100°C (Tp: 100°C), T120°C (Tp: 120°C)	KS21
	Combined KF22, KS21 and ATEX Intrinsically safe Ex ic ^{**1,3} [ATEX Intrinsically safe Ex ic] Applicable Standard: EN 60079-0:2012, EN 60079-11:2012 II 3G Ex ic IIC T4 Gc, Amb. Temp.: -30 to 60°C (-22 to 140°F) ^{**2} Ui=30 V, Ci=27.6 nF, Li=0 μH	KU22

Item	Description	Code
Canadian Standards Association (CSA)	<p>CSA Explosionproof Approval *1 Certificate: 2014354 Applicable Standard: C22.2 No.0, C22.2 No.0.4, C22.2 No.0.5, C22.2 No.25, C22.2 No.30, C22.2 No.94, C22.2 No.60079-0, C22.2 No.60079-1, C22.2 No.61010-1, C22.2 No.61010-2-030 Explosion-proof for Class I, Groups B, C and D. Dustignition-proof for Class II/III, Groups E, F and G. When installed in Division 2, "SEAL NOT REQUIRED" Enclosure: Type 4X, Temp. Code: T6...T4 Ex d IIC T6...T4 Enclosure: IP66/IP67 Max.Process Temp.: T4;120°C(248°F), T5;100°C(212°F), T6; 85°C(185°F) Amb.Temp.: -50 to 75°C(-58 to 167°F) for T4, -50 to 80°C(-58 to 176°F) for T5, -50 to 75°C(-58 to 167°F) for T6 *2 Process Sealing Certification Dual Seal Certified by CSA to the requirement of ANSI/ISA 12.27.01 No additional sealing required Primary seal failure annunciation: at the zero adjustment screw</p>	CF1
	<p>CSA Intrinsically safe Approval *1*3 Certificate: 1606623 [For CSA C22.2] Applicable Standard: C22.2 No.0, C22.2 No.0.4, C22.2 No.25, C22.2 No.94, C22.2 No.157, C22.2 No.213, C22.2 No.61010-1, C22.2 No.60079-0, C22.2 No.61010-2-030 Intrinsically Safe for Class I, Division 1, Groups A, B, C & D, Class II, Division 1, Groups E, F & G, Class III, Division 1, Nonincendive for Class I, Division 2, Groups A, B, C & D, Class II, Division 2, Groups F & G, Class III, Division 1 Enclosure: Type 4X, Temp. Code: T4 Amb. Temp.: -50 to 60°C(-58 to 140°F) *2 Electrical Parameters: [Intrinsically Safe] Vmax=30V, Imax=200mA, Pmax=0.9W, Ci=10nF, Li=0 μH [Nonincendive] Vmax=30V, Ci=10nF, Li=0 μH [For CSA E60079] Applicable Standard: CAN/CSA E60079-11, CAN/CSA E60079-15, IEC 60529:2001 Ex ia IIC T4, Ex nL IIC T4 Enclosure: IP66/IP67 Amb. Temp.: -50 to 60°C(-58 to 140°F) *2, Max. Process Temp.: 120°C(248°F) Electrical Parameters: [Ex ia] Ui=30V, li=200mA, Pi=0.9W, Ci=10nF, Li=0 μH [Ex nL] Ui=30V, Ci=10nF, Li=0 μH Process Sealing Certification Dual Seal Certified by CSA to the requirement of ANSI/ISA 12.27.01 No additional sealing required Primary seal failure annunciation: at the zero adjustment screw</p>	CS1
	Combined CF1 and CS1 *1*3	CU1
IECEx	<p>IECEx Flameproof Approval *1 Applicable Standard: IEC 60079-0:2011, IEC60079-1:2007-4 Certificate: IECEx CSA 07.0008 Flameproof for Zone 1, Ex d IIC T6...T4 Gb Enclosure: IP66/IP67 Max.Process Temp.: T4;120°C(248°F), T5;100°C(212°F), T6; 85°C(185°F) Amb.Temp.: -50 to 75°C(-58 to 167°F) for T4, -50 to 80°C(-58 to 176°F) for T5, -50 to 75°C(-58 to 167°F) for T6</p>	SF2
	<p>IECEx Intrinsically safe and Flameproof Approval *1*3 Intrinsically safe Ex ia Certificate: IECEx DEK 11.0081X Applicable Standard: IEC 60079-0:2011, IEC 60079-11:2011, IEC 60079-26:2006 Ex ia IIC T4 Ga Amb. Temp.: -50 to 60 °C(-58 to 140 °F), Max. Process Temp.: 120 °C(248 °F) Electrical Parameters: Ui=30 V, li=200 mA, Pi=0.9 W, Ci=27.6 nF, Li=0 μH Intrinsically safe Ex ic Certificate: IECEx DEK 13.0061X Applicable Standard: IEC 60079-0:2011, IEC 60079-11:2011 Ex ic IIC T4 Gc IP code: IP66 Amb. Temp.: -30 to 60°C(-22 to 140°F) *2, Max. Process Temp.: 120°C(248°F) Electrical Parameters: Ui=30V,Ci=27.6 nF, Li=0 μH Flameproof Certificate: IECEx CSA 07.0008 Applicable Standard: IEC 60079-0:2011, IEC60079-1:2007-4 Flameproof for Zone 1, Ex d IIC T6...T4 Gb Enclosure: IP66/IP67 Max.Process Temp.: T4;120°C(248°F), T5;100°C(212°F), T6; 85°C(185°F) Amb.Temp.: -50 to 75°C(-58 to 167°F) for T4, -50 to 80°C(-58 to 176°F) for T5, -50 to 75°C(-58 to 167°F) for T6</p>	SU21

*1: Applicable for Electrical connection code 2, 4, 7, 9, C and D.
 *2: Lower limit of ambient temperature is -15°C (5°F) when /HE is specified.
 *3: Not applicable for output signal code Q.

OPTIONAL SPECIFICATIONS

Item		Description	Code	
Painting	Color change	Amplifier cover only *1	P□	
		Amplifier cover and terminal cover, Munsell 7.5 R4/14	PR	
	Coating change	Anti-corrosion coating *1*2	X2	
316 SST exterior parts		316 SST zero-adjustment screw and setscrews *3	HC	
Fluoro-rubber O-ring		All O-rings of amplifier housing. Lower limit of ambient temperature: -15°C (5°F)	HE	
Lightning protector		Transmitter power supply voltage: 10.5 to 32 V DC (10.5 to 30 V DC for intrinsically safe type.) Allowable current: Max. 6000 A (1×40 μs), Repeating 1000 A (1×40 μs) 100 times Applicable Standards: IEC 61000-4-4, IEC 61000-4-5	A	
Oil-prohibited use		Degrease cleansing treatment	K1	
Oil-prohibited use with dehydrating treatment		Degrease cleansing and dehydrating treatment	K5	
Calibration units *4*16		P calibration (psi unit)	(See Table for Span and Range Limits.) D1	
		bar calibration (bar unit)		D3
		M calibration (kgf/cm ² unit)		D4
Teflon film *5*6		Diaphragm protection from sticky process fluid by FEP Teflon film attached with fluorinated oil. Operation range: 20 to 150°C, 0 to 2 MPa (Not applicable for vacuum service).	TF1	
Operating temperature correction *7		Adjusting range: 80°C to Maximum temperature of specified fill fluid	R	
Capillary without PVC sheaths		When ambient temperature exceeds 100°C, or use of PVC is prohibited	V	
Output limits and failure operation *8		Failure alarm down-scale: Output status at CPU failure and hardware error is -5%, 3.2mA DC or less for 4 to 20 mA output type, and -5%, 0.8V DC or less for 1 to 5 V output type.	C1	
		NAMUR NE43 Compliant Output signal limits: 3.8 mA to 20.5 mA *17	Failure alarm down-scale: Output status at CPU failure and hardware error is -5%, 3.2 mA DC or less. C2	
			Failure alarm up-scale: Output status at CPU failure and hardware error is 110%, 21.6 mA or more. C3	
Gold-plated diaphragm *9		Inside of isolating diaphragms (fill fluid side) are gold plated, effective for hydrogen permeation.	A1	
Wired tag plate		316 SST tag plate wired onto transmitter	N4	
Data configuration at factory *10		Data configuration for HART communication type	Software damping, Descriptor, Message CA	
		Data configuration for BRAIN communication type	Software damping CB	
Material certificate		Process flange, Block	For Flush type M2W	
		Process flange, Block, Ring *11		M5W
		Process flange, Block, Pipe, Base	For Extended type M2E	
		High Pressure side: Process flange, Block, Pipe, base Low Pressure side: Process flange, Block	For Combination type M2Y	
Pressure test/ Leak test certificate *12*13		[Flange rating]	[Test pressure]	
		JIS 10K	2 MPa (290 psi)	T51
		JIS 20K	5 MPa (720 psi)	T54
		JIS 40K *2	10 MPa (1450 psi)	T57
		ANSI/JPI Class 150	3 MPa (430 psi)	Nitrogen (N ₂) Gas *15 Retention time: one minute
		ANSI/JPI Class 300 *5	8 MPa (1160 psi)	
		ANSI/JPI Class 300 *14	7 MPa (1000 psi)	
		ANSI/JPI Class 600 *5	16 MPa (2300 psi)	
			T52	
			T56	
			T55	
			T58	

- *1: Not applicable for amplifier housing code 2 and 3.
- *2: Not applicable with color change option.
- *3: 316 or 316L SST. The specification is included in amplifier code 2.
- *4: The unit of MWP (Max. working pressure) on the name plate of a housing is the same unit as specified by option code D1, D3, and D4.
- *5: Applicable for flush type (process connection style code W.)
- *6: Applicable for flushing connection ring code 0.
- *7: Specify the process operating temperature for zero correction. Example: Zero correction by process temperature 90°C.
- *8: Applicable for output signal code D and J. The hardware error indicates faulty amplifier or capsule.
- *9: Applicable for wetted parts material code SW, SE, SY, and HW.
- *10: Also see 'Ordering Information.'
- *11: Applicable for flushing connection ring code 1, 2, 3, and 4.
- *12: The unit on the certificate is always MPa regardless of selection of option code D1, D3, or D4.
- *13: A flushing connection ring will not be applied when conducting the pressure test or leak test.
- *14: Applicable for extended type and Combination type (process connection style code E and Y.)
- *15: Pure nitrogen gas is used for oil-prohibited use (option code K1 and K5.)
- *16: Not applicable for Fill fluid code 1, 2, or 4.
- *17: The 1 to 5 V voltage output corresponding to 4 to 20 mA current output is applied to output signal code Q which is non-compliant to NAMUR NE43.

■ DIMENSIONS

Unit: mm (approx.inch)

< Transmitter body section >

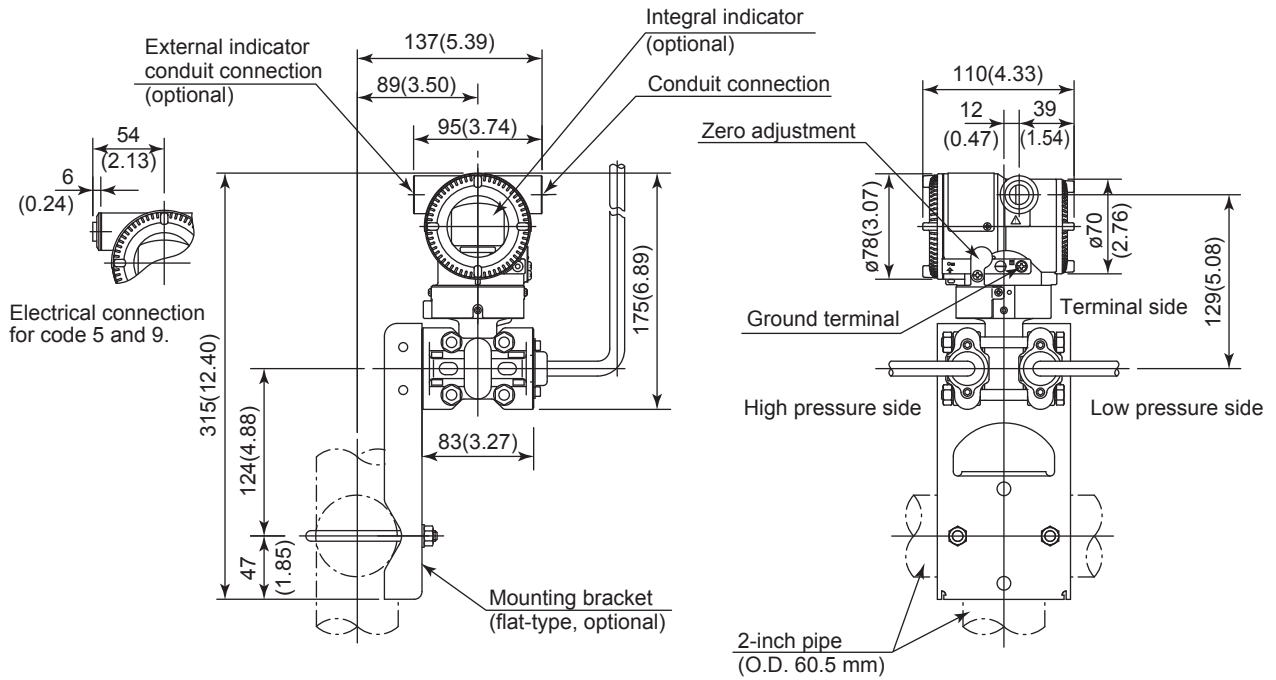

F10E.ai

● Terminal Configuration

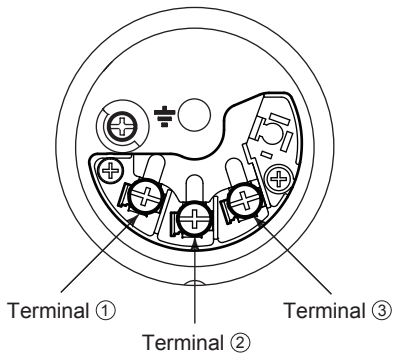

● Terminal Wiring for 4 to 20 mA output, FOUNDATION Fieldbus and PROFIBUS PA communication types

SUPPLY +	①	Power supply and output terminals
-	②	
CHECK +	③	External indicator (ammeter) terminals*1*2
-	②	
		Ground terminal

*1: When using an external indicator or check meter, the internal resistance must be 10 Ω or less.

*2: Not available for FOUNDATION Fieldbus and PROFIBUS PA communication types.

● Terminal Wiring for 1 to 5 V output

SUPPLY +	①	Power supply terminals
-	②	
VOUT +	③	1 to 5 V DC with HART communication terminals
-	②	
		Ground terminal

Three or four wire connection. For four wire connection, both supply and signal lines use SUPPLY - terminal.

F13E.ai

< Diaphragm seal section >

Unit: mm (approx.inch)

• Flush type

• No ring (Flushing connection ring code 0)

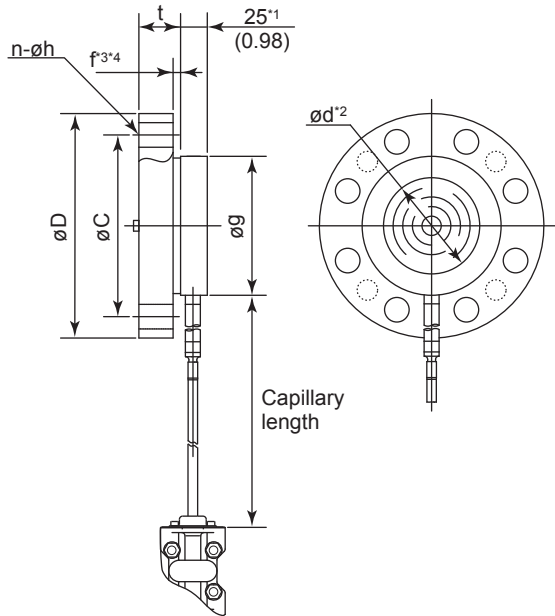

• With ring (Flushing connection ring code 1, 2, 3, and 4)

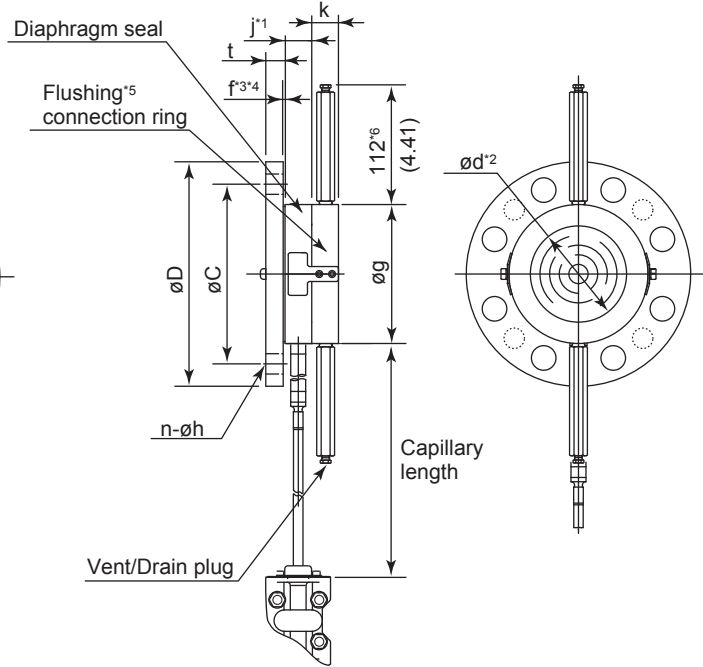

• Extended type

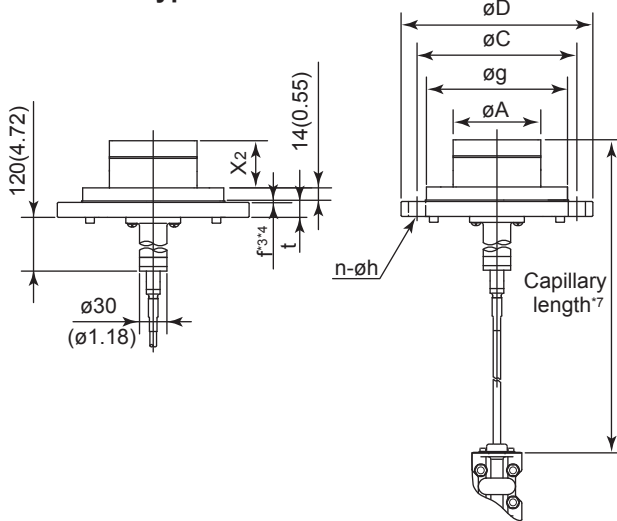

- *1: When wetted parts material code UW (titanium), value is 34 (1.34)
- *2: Indicates inside diameter of gasket contact surface
- *3: In case where process flange material is JIS S25C, value of f is 0.
- *4: In case where process flange material is JIS SUS304 in ANSI/JPI flange, value of f is included in t.

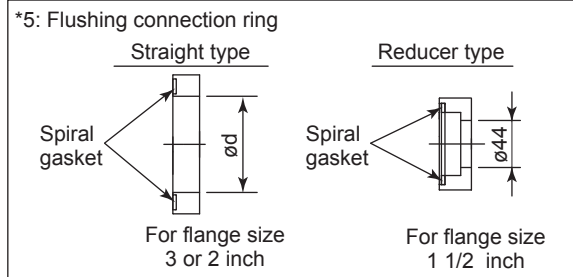

- *5: Flushing connection ring
- *6: When option code K1 or K5 is selected, add 11 mm (0.28 inch.)
- *7: The specified capillary length includes the extension length (X₂) and the flange thickness (t).

• Extension length (X₂)

Extension code	X ₂
2	50 (1.97)
4	100 (3.94)
6	150 (5.91)

F11E.ai

Unit: mm (approx.inch)

● Combination type

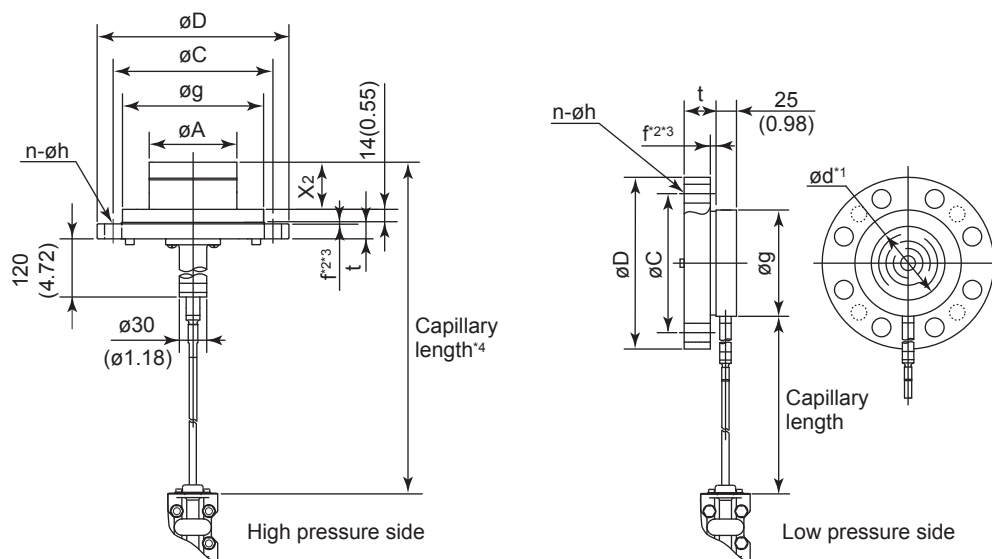

- *1: Indicates inside diameter of gasket contact surface.
- *2: In case where process flange material is JIS S25C, value of f is 0.
- *3: In case where process flange material is JIS SUS304 in ANSI/JPI flange, value of f is included in t.
- *4: The specified capillary length includes the extension length (X_2) and the flange thickness (t).

● Extension length (X_2)

Extension code	X_2
1	50(1.97)
3	100(3.94)
5	150(5.91)

F12E.ai

Process flange size: 4 inch (100 mm)

Code	Flange rating	ϕD	ϕC	ϕg	ϕd	t	f^{3*4}	Bolt holes		j	k	ϕA
								No.(n)	Dia.(ϕh)			
J1	JIS 10K	210 (8.27)	175 (6.89)	155 (6.10)	—	18 (0.71)	0	8	19 (0.75)	—	—	96±0.5 (3.78±0.02)
J2	JIS 20K	225 (8.86)	185 (7.28)	155 (6.10)	—	24 (0.94)	0	8	23 (0.91)	—	—	96±0.5 (3.78±0.02)
A1	ANSI class 150	228.6 (9.00)	190.5 (7.50)	155 (6.10)	—	23.9 (0.94)	1.6 (0.06)	8	19.1 (0.75)	—	—	96±0.5 (3.78±0.02)
A2	ANSI class 300	254 (10.00)	200.2 (7.88)	155 (6.10)	—	31.8 (1.25)	1.6 (0.06)	8	22.4 (0.88)	—	—	96±0.5 (3.78±0.02)
P1	JPI class 150	229 (9.02)	190.5 (7.50)	155 (6.10)	—	24 (0.94)	1.6 (0.06)	8	19 (0.75)	—	—	96±0.5 (3.78±0.02)
P2	JPI class 300	254 (10.0)	200.2 (7.88)	155 (6.10)	—	32 (1.26)	1.6 (0.06)	8	22 (0.87)	—	—	96±0.5 (3.78±0.02)
D2	DIN PN10/16	220 (8.66)	180 (7.09)	155 (6.10)	—	20 (0.79)	0	8	18 (0.71)	—	—	96±0.5 (3.78±0.02)
D4	DIN PN25/40	235 (9.25)	190 (7.48)	155 (6.10)	—	24 (0.94)	0	8	22 (0.87)	—	—	96±0.5 (3.78±0.02)

Unit: mm (approx.inch)

Process flange size: 3 inch (80 mm)

Code	Flange rating	øD	øC	øg	ød*2	t	f ^{3*4}	Bolt holes		j*1	k	øA
								No.(n)	Dia.(øh)			
J1	JIS 10K	185 (7.28)	150 (5.91)	130 (5.12)	90 (3.54)	18 (0.71)	0	8	19 (0.75)	25 (0.98)	27 (1.06)	71±0.5 (2.8±0.02)
J2	JIS 20K	200 (7.87)	160 (6.30)	130 (5.12)	90 (3.54)	22 (0.87)	0	8	23 (0.91)	25 (0.98)	27 (1.06)	71±0.5 (2.8±0.02)
J4	JIS 40K	210 (8.27)	170 (6.69)	130 (5.12)	90 (3.54)	32 (1.26)	0	8	23 (0.91)	25 (0.98)	27 (1.06)	—
A1	ANSI class 150	190.5 (7.50)	152.4 (6.00)	130 (5.12)	90 (3.54)	23.9 (0.94)	1.6 (0.06)	4	19.1 (0.75)	25 (0.98)	27 (1.06)	71±0.5 (2.8±0.02)
A2	ANSI class 300	209.6 (8.25)	168.1 (6.62)	130 (5.12)	90 (3.54)	28.5 (1.12)	1.6 (0.06)	8	22.4 (0.88)	25 (0.98)	27 (1.06)	71±0.5 (2.8±0.02)
A4	ANSI class 600	209.6 (8.25)	168.1 (6.62)	130 (5.12)	90 (3.54)	38.2 (1.50)	6.4 (0.25)	8	22.4 (0.88)	25 (0.98)	27 (1.06)	—
P1	JPI class 150	190 (7.48)	152.4 (6.00)	130 (5.12)	90 (3.54)	24 (0.94)	1.6 (0.06)	4	19 (0.75)	25 (0.98)	27 (1.06)	71±0.5 (2.8±0.02)
P2	JPI class 300	210 (8.27)	168.1 (6.61)	130 (5.12)	90 (3.54)	28.5 (1.12)	1.6 (0.06)	8	22 (0.87)	25 (0.98)	27 (1.06)	71±0.5 (2.8±0.02)
P4	JPI class 600	210 (8.27)	168.1 (6.61)	130 (5.12)	90 (3.54)	38.4 (1.51)	6.4 (0.25)	8	22 (0.87)	25 (0.98)	27 (1.06)	—
D2	DIN PN10/16	200 (7.87)	160 (6.30)	130 (5.12)	90 (3.54)	20 (0.79)	0	8	18 (0.71)	25 (0.98)	27 (1.06)	71±0.5 (2.8±0.02)
D4	DIN PN25/40	200 (7.87)	160 (6.30)	130 (5.12)	90 (3.54)	24 (0.94)	0	8	18 (0.71)	25 (0.98)	27 (1.06)	71±0.5 (2.8±0.02)
D5	DIN PN64	215 (8.46)	170 (6.69)	130 (5.12)	90 (3.54)	28 (1.10)	0	8	22 (0.87)	25 (0.98)	27 (1.06)	—

Process flange size: 2 inch (50 mm)

Code	Flange rating	øD	øC	øg	ød*2	t	f ^{3*4}	Bolt holes		j	k
								No.(n)	Dia.(øh)		
J1	JIS 10K	155 (6.10)	120 (4.72)	100 (3.94)	61 (2.40)	16 (0.63)	0	4	19 (0.75)	25 (0.98)	27 (1.06)
J2	JIS 20K	155 (6.10)	120 (4.72)	100 (3.94)	61 (2.40)	18 (0.71)	0	8	19 (0.75)	25 (0.98)	27 (1.06)
J4	JIS 40K	165 (6.50)	130 (5.12)	100 (3.94)	61 (2.40)	26 (1.02)	0	8	19 (0.75)	25 (0.98)	27 (1.06)
A1	ANSI class 150	152.4 (6.00)	120.7 (4.75)	100 (3.94)	61 (2.40)	19.1 (0.75)	1.6 (0.06)	4	19.1 (0.75)	25 (0.98)	27 (1.06)
A2	ANSI class 300	165.1 (6.50)	127.0 (5.00)	100 (3.94)	61 (2.40)	22.4 (0.88)	1.6 (0.06)	8	19.1 (0.75)	25 (0.98)	27 (1.06)
A4	ANSI class 600	165.1 (6.50)	127.0 (5.00)	100 (3.94)	61 (2.40)	31.8 (1.25)	6.4 (0.25)	8	19.1 (0.75)	25 (0.98)	27 (1.06)
P1	JPI class 150	152 (5.98)	120.6 (4.75)	100 (3.94)	61 (2.40)	19.5 (0.77)	1.6 (0.06)	4	19 (0.75)	25 (0.98)	27 (1.06)
P2	JPI class 300	165 (6.50)	127.0 (5.00)	100 (3.94)	61 (2.40)	22.4 (0.88)	1.6 (0.06)	8	19 (0.75)	25 (0.98)	27 (1.06)
P4	JPI class 600	165 (6.50)	127.0 (5.00)	100 (3.94)	61 (2.40)	31.9 (1.26)	6.4 (0.25)	8	19 (0.75)	25 (0.98)	27 (1.06)
D2	DIN PN10/16	165 (6.50)	125 (4.92)	100 (3.94)	61 (2.40)	18 (0.71)	0	4	18 (0.71)	25 (0.98)	27 (1.06)
D4	DIN PN25/40	165 (6.50)	125 (4.92)	100 (3.94)	61 (2.40)	20 (0.79)	0	4	18 (0.71)	25 (0.98)	27 (1.06)
D5	DIN PN64	180 (7.09)	135 (5.31)	100 (3.94)	61 (2.40)	26 (1.02)	0	4	22 (0.87)	25 (0.98)	27 (1.06)

Process flange size: 1 1/2 inch (40 mm)

Code	Flange rating	øD	øC	øg	ød*2	t	f ^{3*4}	Bolt holes		j	k
								No.(n)	Dia.(øh)		
J1	JIS 10K	140 (5.51)	105 (4.13)	86 (3.39)	44 (1.73)	16 (0.63)	0	4	19 (0.75)	27 (1.06)	30 (1.18)
J2	JIS 20K	140 (5.51)	105 (4.13)	86 (3.39)	44 (1.73)	18 (0.71)	0	4	19 (0.75)	27 (1.06)	30 (1.18)
J4	JIS 40K	160 (6.30)	120 (4.72)	86 (3.39)	44 (1.73)	24 (0.94)	0	4	23 (0.91)	27 (1.06)	30 (1.18)
A1	ANSI class 150	127 (5.00)	98.6 (3.88)	86 (3.39)	44 (1.73)	17.5 (0.69)	1.6 (0.06)	4	15.9 (0.63)	27 (1.06)	30 (1.18)
A2	ANSI class 300	155.4 (6.12)	114.3 (4.50)	86 (3.39)	44 (1.73)	20.6 (0.81)	1.6 (0.06)	4	22.4 (0.88)	27 (1.06)	30 (1.18)
A4	ANSI class 600	155.4 (6.12)	114.3 (4.50)	86 (3.39)	44 (1.73)	28.8 (1.13)	6.4 (0.25)	4	22.4 (0.88)	27 (1.06)	30 (1.18)
P1	JPI class 150	127 (5.00)	98.6 (3.88)	86 (3.39)	44 (1.73)	17.6 (0.69)	1.6 (0.06)	4	16 (0.63)	27 (1.06)	30 (1.18)
P2	JPI class 300	155 (6.10)	114.3 (4.50)	86 (3.39)	44 (1.73)	20.6 (0.81)	1.6 (0.06)	4	22 (0.87)	27 (1.06)	30 (1.18)
P4	JPI class 600	155 (6.10)	114.3 (4.50)	86 (3.39)	44 (1.73)	28.9 (1.14)	6.4 (0.25)	4	22 (0.87)	27 (1.06)	30 (1.18)

*1: When wetted parts material code UW (titanium) is selected, value is 34 (1.34).

*2: Indicates inside diameter of gasket contact surface.

*3: In case where process flange material is JIS S25C, value of f is 0.

*4: In case where process flange material is JIS SUS304 in ANSI/JPI flange, value of f is included in t.

< Ordering Information >

Specify the following when ordering

1. Model, suffix codes, and option codes
2. Calibration range and units:
 - 1) Calibration range can be specified with range value specifications up to 5 digits (excluding any decimal point) for low or high range limits within the range of -32000 to 32000. When reverse range is designated, specify LRV as greater than URV. When square root output mode is specified, LRV must be "0(zero)".
 - 2) Specify only one unit from the table, 'Factory setting.'
3. Select linear or square root for output mode and display mode.
 Note: If not specified, the instrument is shipped set for linear mode.
4. Display scale and units (for transmitters equipped with the integral indicator only)
 Specify either 0 to 100 % or 'Range and Unit' for engineering units scale:
 Scale range can be specified with range limit specifications up to 5 digits (excluding any decimal point) for low or high range limits within the range of -32000 to 32000. Unit display consists of 6-digit, therefore, if the specified scaling unit excluding '/' is longer than 6-characters, the first 6 characters will be displayed on the unit display.
5. HART PROTOCOL
 When output signal code is "J", specify the HART protocol revision "5" or "7".
6. TAG NO (if required)
 Specified characters (up to 16 characters for BRAIN, 22 characters for HART) are engraved on the stainless steel tag plate fixed on the housing.
7. SOFTWARE TAG (for HART only, if required)
 Specified characters (up to 32 characters) are set as "Tag" (the first 8 characters) and "Long tag"^{*1} (32 characters) in the amplifier memory. Use alphanumeric capital letters.
 When the "SOFTWARE TAG" is not specified, specified "TAG NO" is set as "Tag" (the first 8 characters) and "Long tag"^{*1} (22 characters) in the amplifier memory.
^{*1}: applicable only when HART 7 is selected.
8. Other factory configurations (if required)
 Specifying option code **CA** or **CB** will allow further configuration at factory. Following are configurable items and setting range.
 [/CA : For HART communication type]
 1) Descriptor (up to 16 characters)
 2) Message (up to 30 characters)
 3) Software damping (0.00 to 100.00 s)
 [/CB : For BRAIN communication type]
 1) Software damping (0.00 to 100.00 s)
9. Process fluid temperature for zero compensation (When /R is specified.)

< Factory Setting >

Tag number	As specified in order
Software damping *1	'2.00 s' or as specified in order
Output mode	'Linear' unless otherwise specified in order
Calibration range lower range value	As specified in order
Calibration range upper range value	As specified in order
Calibration range units	Selected from mmH ₂ O, mmH ₂ O(68°F), mmAq ² , mmWG ² , mmHg, Pa, hPa ² , kPa, MPa, mbar, bar, gf/cm ² , kgf/cm ² , inH ₂ O, inH ₂ O(68°F), inHg, ftH ₂ O, ftH ₂ O(68°F) or psi. (Only one unit can be specified.)
Display setting	Designated differential pressure value specified in order. (% or user scaled value.) Display mode 'Linear' or 'Square root' is also as specified in order.
Static pressure display range	'0 to 25 MPa' for M and H capsule, absolute value. Measuring low pressure side.

- *1: To specify these items at factory, /CA or /CB option is required.
- *2: Not available for HART protocol type.

< Material Cross Reference >

ASTM	JIS
316	SUS316
F316	SUSF316
316L	SUS316L
F316L	SUSF316L
304	SUS304
F304	SUSF304
660	SUH660
B7	SNB7
CF-8M	SCS14A