

# General Specifications

GS 11Y01B01-01E-A

Model TDLS200 [style: S2.01]  
Tunable Diode Laser  
Spectroscopy (TDLS) Analyzer

**TDLS200**  
**TruePeak**

The TruePeak Tunable Diode Laser Spectroscopy (TDLS) Analyzer is capable of measuring a number of near-infrared absorbing gases in difficult process applications. With the capability of measuring at very high temperature, high pressures and under difficult conditions (corrosive, aggressive, high particulate service), the TruePeak analyzer is one of the most robust process analyzers available. Most applications are measured in-situ, reducing installation and maintenance costs. In addition, most measurements are rapid (5 seconds) and interference free, offering improved accuracy when compared to other process analyzers.

### Typical gases measured include:

- Oxygen in process applications and combustion applications. Process temperatures can be as high as 1500°C, pressures can be as high as 10 bar. Measurement span is typically between 1% and 100% oxygen.
- Carbon Monoxide in process and combustion applications. Process temperatures can be as high as 1500°C. Two versions are available, high sensitivity with ppm detection limits possible and standard sensitivity for high ppm and percent level CO measurements
- Part per million Moisture in aggressive process streams. Sub-ppm detection limits are possible with measurement in corrosive and aggressive process streams

Other applications and gases are possible with the TruePeak TDLS. Please fill out the Application Data Sheet at the end of this document and send to Yokogawa.

### Features

#### TruePeak V3.0 Software

- In Situ or Extractive Analysis
- Fast Response (2-20 seconds)
- Interference Free for most applications
- TruePeak Measurement Capable of measuring under changing pressure, temperature and background
- Process Pressures up to 20 Bar
- Process Temperature up to 1500°C
- Optical Measurement, no sensor contact with process
- Low LTCO<sup>1</sup> (no moving parts, high MTTF<sup>2</sup> for components)
- Flexible Installation Options
- On Board Diagnostics
- ATEX Group II for zone 1 (Cat 2G) or 2 (Cat 3G) with purge systems

<sup>1</sup> Long term cost of ownership  
<sup>2</sup> Mean time to failure

### TruePeak TDLS



### Optional Remote Interface Unit



### Process Interface & Alignment



### System configuration

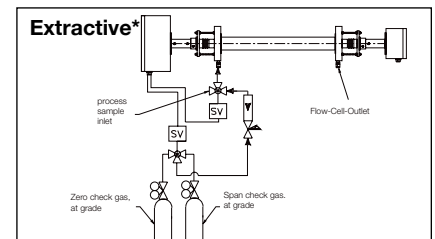
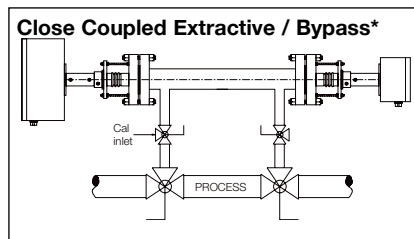
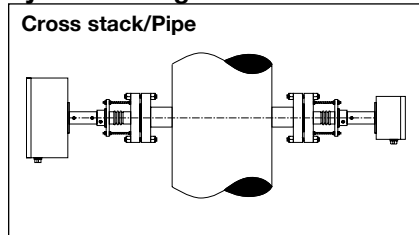

\* Contact Yokogawa for further information

**YOKOGAWA** ◆

Yokogawa Corporation of America  
2 Dart Road, Newnan, Georgia U.S.A. 30265  
Tel: 1-800-258-2552 Fax: 1-770-254-0928

GS 11Y01B01-01E-A  
©Copyright April 2008  
8th Edition February 13, 2013

## Operational Principle

Tunable Diode Laser Spectroscopy (or TDLS) measurements are based on absorption spectroscopy. The TruePeak Analyzer is a TDLS system and operates by measuring the amount of laser light that is absorbed (lost) as it travels through the gas being measured. In the simplest form a TDLS analyzer consists of a laser that produces infrared light, optical lenses to focus the laser light through the gas to be measured and then on to a detector, the detector, and electronics that control the laser and translate the detector signal into a signal representing the gas concentration.

Gas molecules absorb light at specific wavelengths, called absorption lines. This absorption follows Beers law.

TDL Analyzers are effectively infra red analyzers which obey the Beer-Lambert Law.

$$I = I_0 \cdot e^{-E \cdot G \cdot L}$$

where I is the radiation intensity after absorption  
 $I_0$  is the initial radiation intensity  
 E is the extinction coefficient  
 G is the gas concentration  
 and L is the path length of the measurement area

**Using a Tunable Diode Laser as a light source for spectroscopy has the following benefits:**

- **Sensitivity.** Application Dependant. Sub-PPM in some applications.
- **Selectivity.** The narrow line width of the laser is able to resolve single absorption lines. This provides more choices of a particular peak to use for measurement, usually allowing one isolated peak to be used.
- **Power.** Diode lasers have power ranging from 0.5mW to 35mW. Also, being highly coherent this allows measurement in optically thick environments (high particulate loading).
- **Monochromatic.** No dispersive element (filter, etc.) required. Light source itself is selective.
- **Tunable.** Wavelength can be swept across the entire absorption feature, this allows resonant (peak) and non resonant (baseline) measurement during every scan. By measuring the baseline and peak, power at the detector can fluctuate rapidly by large amounts without affecting the measurement. This is useful for high particulate applications.

## Measurement

- During measurement the laser is held at a fixed temperature. This is the coarse wavelength adjustment.
- A current ramp is fed to the laser. This is the fine wavelength adjustment (figure 1).
- The current is ramped to scan across the wavelength region desired.
- The collimated light passes through the gas to be measured. The amount of light absorbed by the peak is proportional to the analyte concentration.
- The light is then focused on a detector (figure 2).
- This signal is used to quantify the light absorbed by the analyte (figure 3).

**Figure 1. Current ramp to laser**

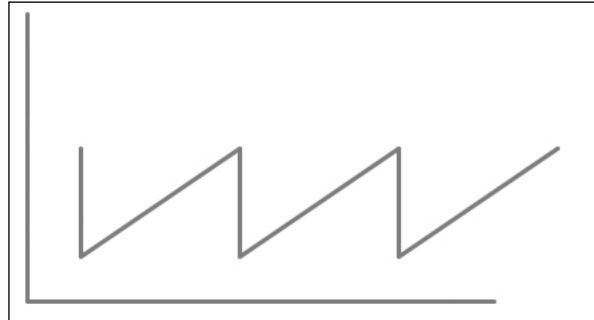

**Figure 2. Signal at Detector**

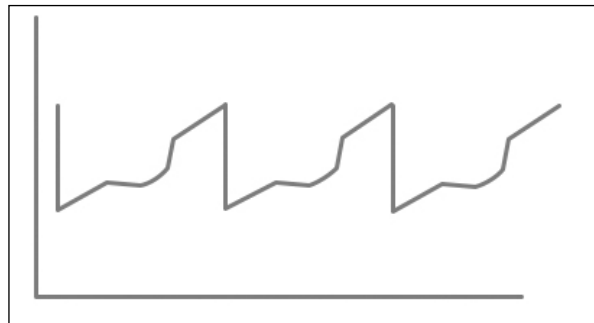

**Figure 3. Processed Detector Signal**

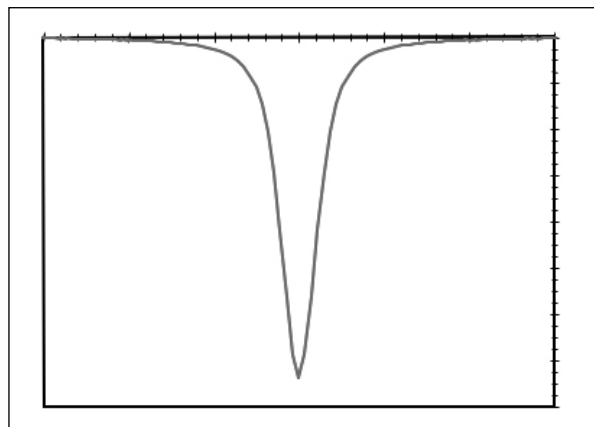

## General Specifications

- A. Measurement range:** Dependent on application, optical path length, process pressure and temperature. Oxygen application typically 0-1% up to 0-100%. All other measured gases range from low ppm to high % levels.
- B. Output signal:** (3x) 4- 20 mA DC with maximum load of 900 Ohm  
Three isolated outputs may be used for gas concentration, transmission, re-transmission of data inputs, dual range, or second gas measurement where applicable.  
3.3 mA user configurable on warnings and faults, according to NAMUR NE43.
- C. Output Span:** Freely programmable within measuring range
- D. Contact outputs:** (3x) configurable relays for Status (Fault, Warning, In Validation, concentration level, etc.) Form C Single Pole Double Throw (SPDT) contact outputs with maximum 1A@24VDC.
- E. Valve control:** (3x) Form C SPDT contact outputs with C connected to 24VDC power supply to activate calibration solenoid valves for zero, span and dynamic spiking (validation) gas. Maximum load 1A (max 10W/ valve for zero and span gas and dynamic spiking).
- F. Current Input** (2x) 4-20 mA inputs for Temperature and Pressure Compensation for loop powered or mains powered (115/220 VAC) mA transmitters for pressure and temperature.
- G. Digital Communication:** Ethernet IEEE 802.3 10/100 mbps, RJ45
- H. Data storage:** USB1 and USB2 connection for data transfer using memory stick, data storage in CF card (result files, spectra capture, configuration data, etc.) Capture rate is configurable typical capacity for results and spectra is 14 days.
- I. Warm-up time:** 5 min for functioning, 60 min for full operation within specifications.
- J. Power Consumption:** 24 VDC, 5A max
- K. Accessories:** 100-240 VAC, 50/60 Hz can be supplied to:  
- Universal Remote Display (URD)  
- Utility Panel(s)  
- Optional Power Supply Unit  
(These devices all supply 24 VDC to power the TDLS Analyzer)
- L. Optical Path Length:** Insitu standard, greater than to 30 meters allowed Minimum, OPL .5 meter  
Flow Cells, bypass installation, 1 meter recommended

**Note:** End User may supply 23.8 to 24.5 VDC direct to analyzer (typ.4A). Optional heat trace system may require additional and/or alternate power supplies.

## Environmental Specifications

- A. Ambient Temperature:** Continuous operation - 50°C to 70°C, with external heating and cooling mechanisms. Start up temperature -20°C to 50°C. Extended temperature installation options are available please contact Yokogawa.
- B. Humidity:** 0- 90 % RH non-condensing or 0- 100% with correct purge gas specifications.
- C. Area Classification:** CE Marked for zone 2 ATEX group II Cat. 3G with purge system EEx pz II T5  
  
Class 1 Div. 2 Group BCD with integral purge kit
- D. Weather resistance:** IP65
- E. Cable entries:** ¾" FNPT threads (unused holes are plugged)
- F. Gas Connections:** Analyzer - ¼" welded Swagelok connection  
Flow Cells - ⅜" and ¼" FNPT (other connections upon request)
- G. Enclosures:** Die Cast copper free Aluminum grade AL SI 12 with a powder coat exterior finish. The alloy is particularly resistant to salt atmosphere, Sulfur gases and galvanic corrosion. Stainless Steel captive screws and optional keypad. Laminated Safety Glass for optional display(s).
- H. Sample Gas Temperature:** Maximum 1500°C, Application Dependant
- I. Sample Gas Pressure:** Maximum (20 bar), Application Dependant
- J. Mounting Flanges:** 2", 3" or 4" 150# ANSI RF or adaptors for DN50 PN16, and DN80 PN16
- K. Mounting Angle:** Flange alignment tolerance within ±2 degrees
- L. Weights, approx:** Launch Unit 15.9 kg x (35lbs), Detect Unit 5.5 kg (12lbs)  
2" 150# Alignment flange 4.5 kg (10lbs),  
4" 150# Alignment flange 9.1 kg (20lbs)
- M. Particulate loading:** Maximum 95% transmission loss
- N. EMC:** Korea Electromagnetic Conformity Standard
- Note:** Each application may differ in maximum limitations depending upon the combination of gas temperature, gas pressure, optical path length and concentration of gas being measured.

## Performance Specification

<b>Repeatability:</b>	Application Dependent
<b>Linearity:</b>	+/- 1% of FS
<b>Up-date Period:</b>	min. 2 seconds, depends on application
<b>Drift:</b>	Application Dependent

## Installation Specifications

**Hazardous Area:** Zone 1: Contact Yokogawa  
Zone 2: ATEX group II Cat. 3G with purge system EEx pz II T5 (-20 < Ta < 50C)

**By Design:** Non-Hazardous Area; Purge required for ATEX zone 1&2 and NEC Class 1 Division 1&2

**Maximum Distance between Launch and Detect:**  
30 m (90 ft)  
Maximum interconnecting cable greater than 50 m

**Wetted Parts:** Analyzer & standard Alignment Flange - 316 SS, BK-7 Glass, Teflon encapsulated Viton and Silicone RTV sealant.

**Optional:** Isolation Flanges and Flow Cells - 316 SS, Sapphire, Kalrez -  
Also available in Monel A400, Hastelloy C-276, Carpenter 20, Titanium Grade 2 and others on request.

## Utilities:

Instrument Air may be used as a purge gas in principle for all of the below applications, but this will depend on the application type and the required precision of the measurement.

Oxygen Analyzer	N <sub>2</sub>
CO Analyzer	N <sub>2</sub> or Instrument Air
CO <sub>2</sub> Analyzer	N <sub>2</sub> or other non-CO <sub>2</sub> containing inert gas
H <sub>2</sub> O ppm Analyzer	N <sub>2</sub> with < 20 ppm levels H <sub>2</sub> O for feed to optional Dryer Package
H <sub>2</sub> O % Analyzer	N <sub>2</sub>

**Flow Rate:**

- 5-30 L/min for window purge
- 2 L/min for validation, calibration and optical purge

## SIL Assessment:

The TDLS200 has a FMEDA assessment by *exida* and is classified as a Type B1 device in compliance with the following standards; IEC 61508 or EN 954-1. Functional Safety of Electrical/electronic/programmable electronic related systems; SIL 1 capability for single device.

\* The TDLS200 is not SIL certified as standard; to be certified the unit must be specified and designed from the beginning to meet all SIL specifications.

## Basic System Configuration

The TruePeak can be installed in a number of ways depending on process requirements. The most typical installation types are shown below, however other installation methods are possible, please contact Yokogawa with your application details.

## Cross Stack/Pipe Configuration

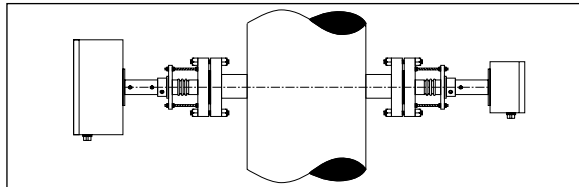

- Measures directly across process pipe or vessel
- Typically has nitrogen or other purge gas protecting process windows
- Span Validation via flow cell (see Operation Specifications).
- Full calibration requires removal from process
- May require pressure and temperature inputs (Application Dependent)
- Multiple methods to increase Optical Path Length (OPL) if needed

## Close Coupled Extractive / Bypass Configuration\*

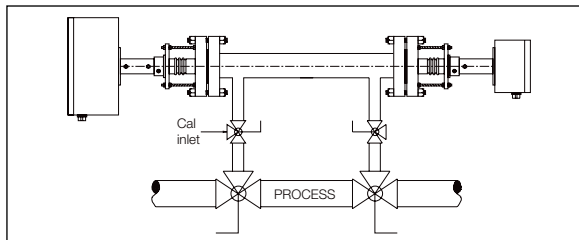

- Measures across a section of pipe where process flow is directed
- The measurement section can be isolated from process flow for full calibration/validation, zero and span
- Process pressure and temperature can be controlled or the analyzer may require pressure and temperature inputs (Application Dependent)
- Length of measurement section dependant on accuracy requirements and process conditions

## Extractive Configuration\*

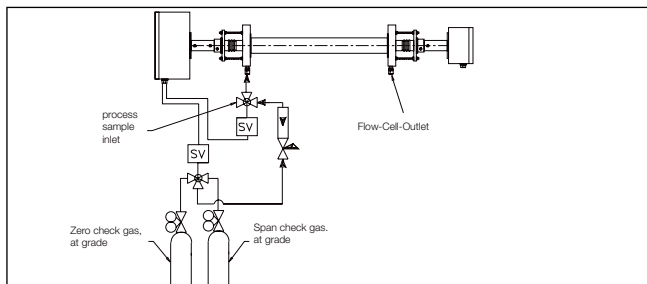

- Sample is fully extracted from process (and may be conditioned before measurement)
- Flow cells are available with ability to purge in front of windows (balanced flow cell) if required
- Process pressure and temperature can be controlled or the analyzer may require pressure and temperature inputs (Application Dependent)
- Length of flow cell dependant on accuracy requirements and process conditions

\* Contact Yokogawa for further details

## Standard Accessories

- Calibration Cell:**
- Used for off-line calibrations and validations
  - Stainless steel 316 with free standing frame
  - Connects Launch and Detect with 72.6 cm (28.6") OPL
- Flow Cells:**
- Used for extracted sample streams at any location
  - 316SS low volume fixed alignment; 50°C, 5.5 bar (80 psig) max
  - Enhanced for 200°C, 20 Bar (290 psig), Sapphire window, Kalrez o-rings and can be constructed from 316SS, Monel A400, Hastelloy C-276, Carpenter 20 and other materials on request to suit the process
- Isolation Flanges:**
- Used for additional protection for in-situ or by-pass installations
  - 2" or 3" 150# or 300# ANSI RF, 4"150#, DN80 PN16 welded 5/8" or M16" bolt studs included sapphire 20 Bar (290 psig) or BK-7 5.5 bar (80 psig) isolation window
  - Kalrez 4079 or 6379 window seal O-ring available, rated max 200°C
  - 316SS, Monel A400, Hastelloy C-276, Carpenter 20, other on request

**Note:** Must use in conjunction with alignment flanges

- Utility Panel:**
- Used for convenient field installation of utilities, configurations for
  - Single, dual or four analyzers
  - Manual or automatic on-line validation (controlled by analyzer)
  - Safe area (GP), Div 2 purged or non-purged, ATEX CAT 2G components
  - Purged controlled with variable area flowmeter.
  - Swagelok® double ferrule stainless steel tube fittings and tubing standard
  - Panel mounted or fiberglass (NEMA 4X/ IP65), with viewing window
  - 5A 24VDC power supply, output to analyzer – requires VAC input power

**Note:** Custom configuration available to suit customer requirements

- Integration:**
- Used for convenient analyzer & extractive system/flow cell integration
  - Free standing frame, galvanized steel with 304SS roof
  - Fiberglass enclosure with powder coated steel frame
  - Heat tracing and insulation for flow cells and sample handling
  - 316SS and/or Monel A400 wetted parts – other on request
  - Sample handling and conditioning systems to suit applications
  - Stream switching manual or automatic (controlled by analyzer)

**Note:** Custom configuration available to suit customer requirements

## Display and Software Functions

### TruePeak v3.0 Software

- Improved gas temperature measurement algorithm for High temperature Oxygen plus Temperature (-X3) analyzer.
  - o Minimum measurable temperature can be configured.
  - o If process temperature is lower than minimum measurable temperature, an analog input will be used so that O<sub>2</sub> reading is still valid.
- 4-20 mA output block mode value can be configured by user
  - o Applies to warning, fault, cal/val, entering menu.
- User may configure validation failure tolerance.
- User may configure alarm digital outputs delay (how many updates).
- User may configure the IP address much easier through TruePeak user interface.
- Two gas offline validation with one initiate. Example, O<sub>2</sub> safety analyzers.
- Two automatic online validations can be configured. Example automatic CO and CH 4 online validations
- Validation failure fault
- Validation alarms can be cleared through TruePeak user interface.

### In-Situ Validation

Validation (shown below) can be performed on-line. A serial validation flow cell is fitted in the analyzer between the laser source and the process window. During normal operation the validation cell is filled with nitrogen (analyzer measuring process gas only). After initiating a validation, this cell is filled with a known standard of the gas being measured, the analyzer will then measure the process gas + the validation gas (dynamic spike). The validation cell flow is then returned to nitrogen (analyzer measuring process gas only).

The analyzer will calculate the validation response by averaging the process readings before and after the dynamic spike and subtracting that value from the reading during the dynamic spike. This provides a relative proof of span and a positive indication of operation.

Calibration must be performed manually. The analyzer is removed from the process connections and installed on a calibration cell. Zero and span gas can then be applied to the analyzer with calibration performed through the user menu.

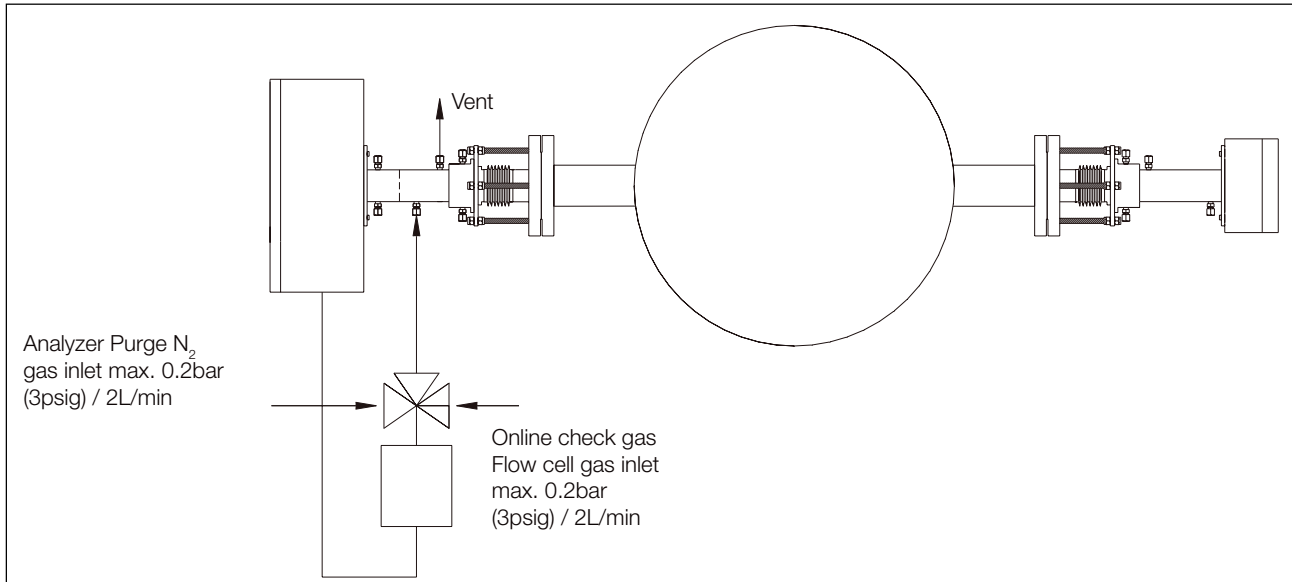

### Extractive or Close Coupled Calibration / Validation:

Validation can be performed manually or automatically with the serial validation cell (span check only described above), or by isolating the analyzer from the process and flowing zero and span gas through the optical path (flow cell or bypass piping).

Calibration must be performed manually. The analyzer is isolated from the process gas, zero and span gas can then be applied to the analyzer with calibration performed through the user menu. For applications where the measured gas is typically not present (0 level concentration), Yokogawa will recommend the validation frequency according to the application.

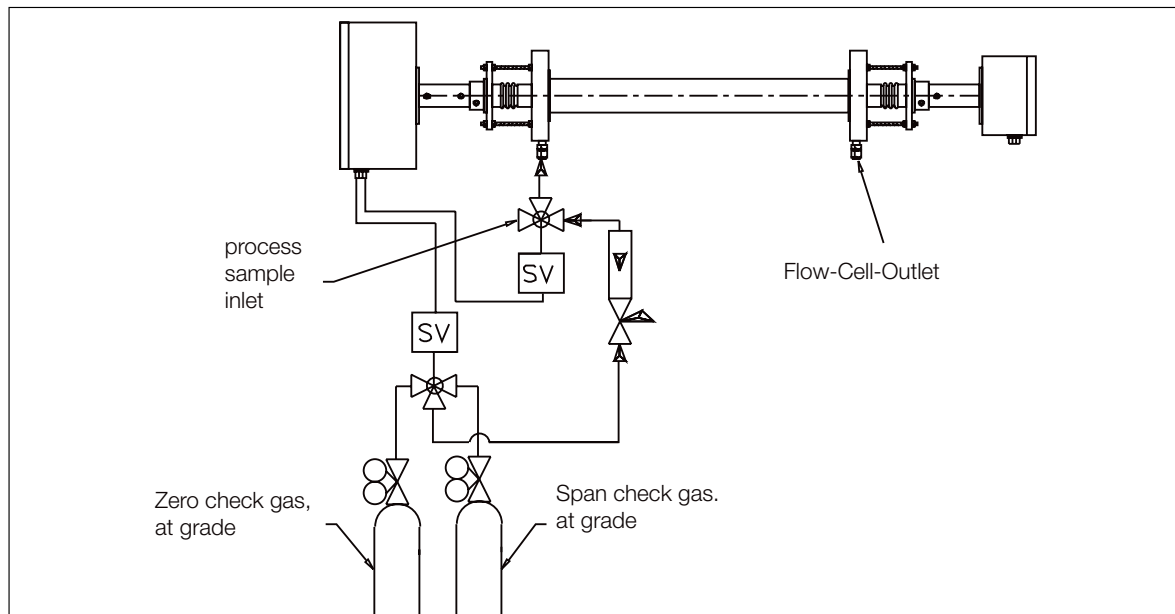

## Dimensions

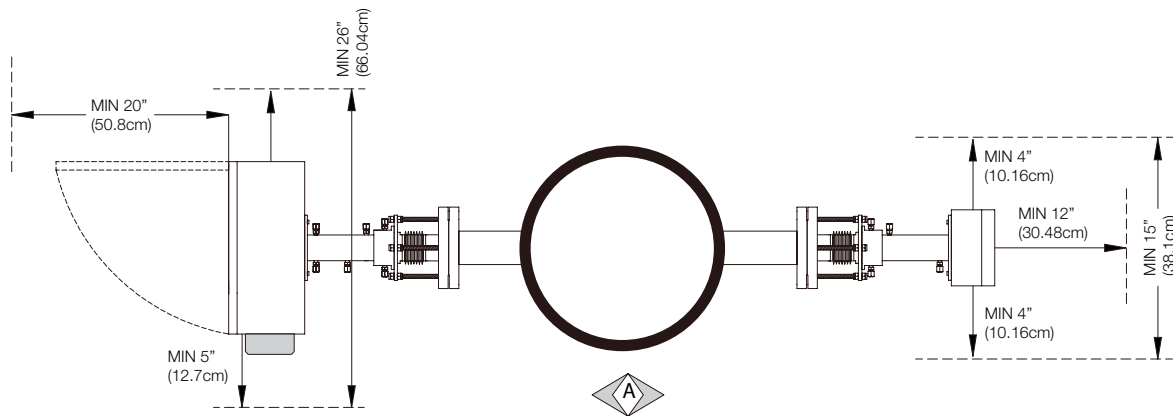
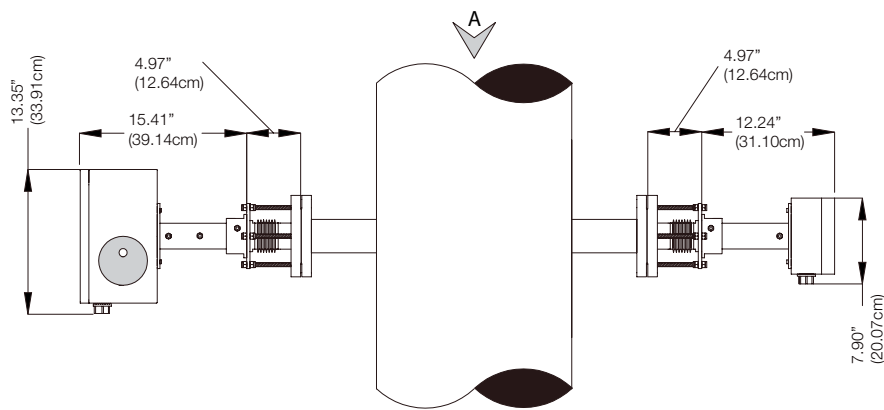
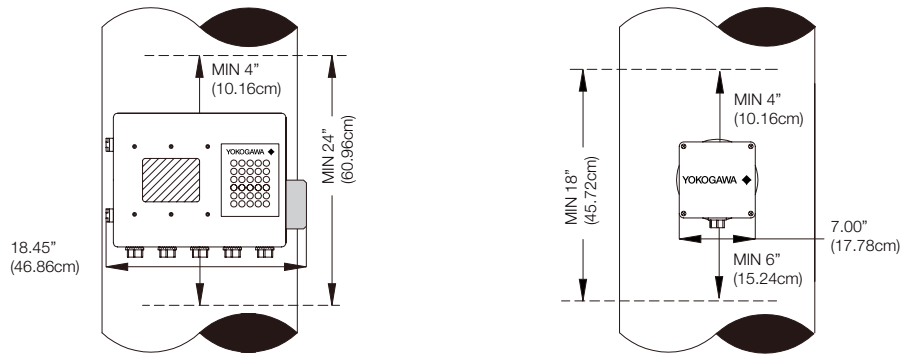

The analyzer requires purge gas  $N_2$  /air/other the flow of which needs to be controlled. Utility panels may be provided in various forms for one or two units to control purge gas and validation gases as standard and additional purge gas for hazardous area application when required. The Utility panel can automatically control via the analyzer validation gases which will indicate whether the analyzer is within calibration.

The Analyzer in normal usage is a non contact device. Purge gases are used to ensure sample does not contact the analyzer, and these gases are often a gas which does not contain the gas to be measured. Nitrogen, for example, is often used as a purge gas in Oxygen measurement. However, depending on the application, it may be possible to use air as a purge gas (even for oxygen measurements) and purge gases are not invariably required.





# Wiring of Launch for the CU version

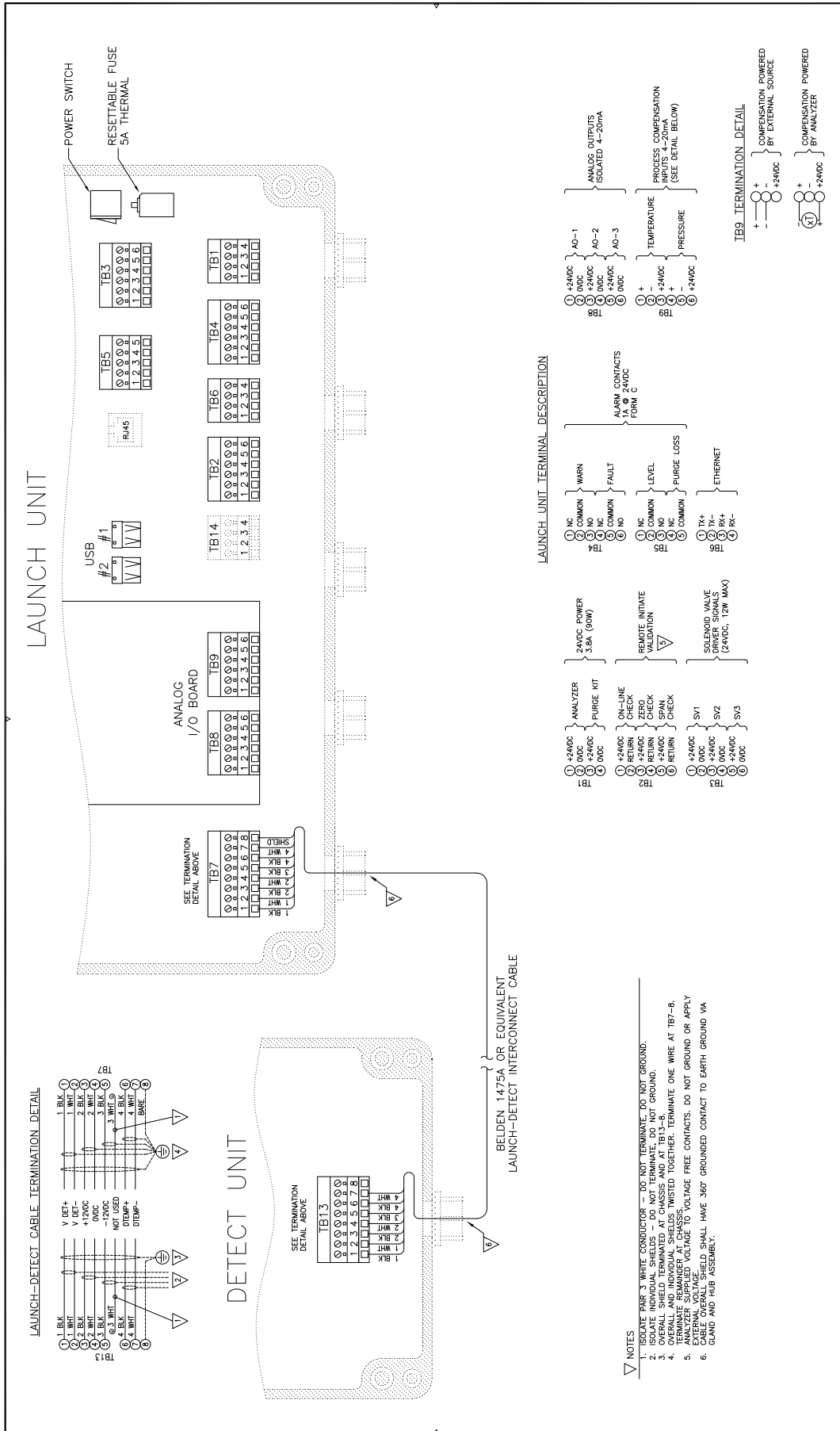

## Model and Suffix Codes

Model	Suffix Code	Option Code	Description
TDLS200	-----	-----	Tunable Diode Laser
Type	-N -G -D -S -J	----- ----- ----- ----- -----	General Purpose (None CE) General Purpose (CE/KC) Class I Div 2 BCD Purged ATEX CAT 3/ zone 2 Purged, KC TIIS Hazardous Area
Gas Parameter	-X1 -X2 -X3 -C1 -C2 -C3 -C4 -A1 -A2 -S1 -D1 -D5 -H1 -H2 -H3 -H4 -K1	----- ----- ----- ----- ----- ----- ----- ----- ----- ----- ----- ----- ----- ----- ----- ----- -----	Oxygen (O <sub>2</sub> ) < 600°C, 0-25% Oxygen (O <sub>2</sub> ) < 1500°C, 0-25% Oxygen (O <sub>2</sub> ) <1500°C, 0-25%/ Temp Carbon Monoxide (CO) % <500°C Carbon Monoxide ppm (CO) <500°C Carbon Monoxide ppm (CO) <1500°C Carbon Monoxide (CO) ppm <1500°C + CH <sub>4</sub> 0-5% Ammonia (NH <sub>3</sub> ) up to 0-5,000ppm Ammonia (NH <sub>3</sub> ) 0-5,000ppm & 0-50% H <sub>2</sub> O Hydrogen Sulfide (H <sub>2</sub> S) up to 0-50% Carbon dioxide (CO <sub>2</sub> ) High Range 0-1; 0-5% Carbon dioxide (CO <sub>2</sub> ) Extend. Range 0=5; 0-50% Water moisture (H <sub>2</sub> O) min 0-30ppm Cl <sub>2</sub> background Water moisture (H <sub>2</sub> O) ppm non-hydrocarbon background Water moisture (H <sub>2</sub> O) ppm Hydrocarbon background High moisture (H <sub>2</sub> O) level min 0-5% Special Applications
Liser Interface	-N -1 -2	----- ----- -----	None- Blind Controller Integral Mini Display Integral Color LCD Backlit
Interface	-N -A -B -2 -3 -4 -5 -8	----- ----- ----- ----- ----- ----- ----- -----	No Process Interface Included Large Aperture Optics with 3" 150# alignment bellows Large Aperture Optics, with 4" 150# alignment bellows 2" 150# Alignment Bellows 3" 150# Alignment Bellows 4" 150# Alignment Bellows DN50 Alignment Bellows DN80 Alignment Bellows
Options		/U ----- /P ----- /D -----	Ext.USB Port IP66 (NOT ATEX) Pressure Comp Curve Diverging Beam No Large Aperture Optics

## User Interface

### 1. Local Analyzer Interface

#### Basic Unit (Blind)



No local interface built-in. USB port is provided for data transfer. To configure, start-up and service the analyzer, User must use: a PC/Laptop with Ethernet (VNC) connection and (VAC) Virtual Analyzer Controller Software Package (included), or a (RIU) Remote Interface Unit.

#### Mini-Display



A 4 line 20 character (4x20) vacuum florescent display (VFD) built in to the door of the launch unit. It will display measurement concentration, Transmission, scrolling Status (including alarm types) and scrolling system information (including process parameters). User must use: a PC/Laptop with Ethernet (VNC) connection and (VAC) Virtual Analyzer Controller Software Package (included), or a (RIU) Remote Interface Unit. A USB port is provided for data transfer.

#### Screen & Keypad



A 30 key stainless steel keypad and 6.5" graphical LCD panel built in to the door of the launch unit. This provides full local interface. It eliminates the need for a PC/laptop or (RIU) Remote Interface Units. USB port is provided for data transfer.

### 2. Remote Interface Unit (RIU)



Use with any type of analyzer, a separate wall mount enclosure with screen and keypad. Connects via Ethernet (VNC), up to 3 (standard) 8 (on request) analyzers. Requires 24 VDC input power

- Wall mount enclosure, IP65 (NEMA 4) powder coated aluminum
- Approx 460x330x180mm (18"w x 13"h x 7"d) weight 11.5 kg (25 lbs)
- Purged for ATEX CAT 2G or CAT 3G, CE, NEC Cl.1, BCD, Division 1 or 2
- Requires 23.5 - 24.5 VDC Input power
- Integral keypad and 6.5" display
- Accepts 8 analyzer Ethernet connections – Standard  
Accepts more analyzer Ethernet connections – On request
- Connection to Analyzer Unit via 8 pair shielded twisted pair cable.

TruePeak Virtual Analyzer Controller (VAC) software included, running Window XP embedded OS.

#### Model And Suffix Code YR200 Remote Interface Unit for TDLS

Model	Suffix	Description
YR200	-----	Remote Interface Unit
Type	-G1 ----- -D2 ----- -A1 -----	General Purpose Hazardous Area Div 2 Hazardous Area ATEX
-----	-N ---	Always N

## Utility Panel

A Utility Panel provides a central location for:

- Inst Air / N<sub>2</sub> supply for purges
- Validation control
- Purge control
- 90-260 VAC line power in and 24 VDC out to each analyzer
- Analog signals
- Digital signals
- Analyzer interface

Yokogawa supplies a single interconnect cable that connects the Utility Panel to the Launch unit for power and signal requirements. Utility Panels for 1 to 4 analyzers are available.

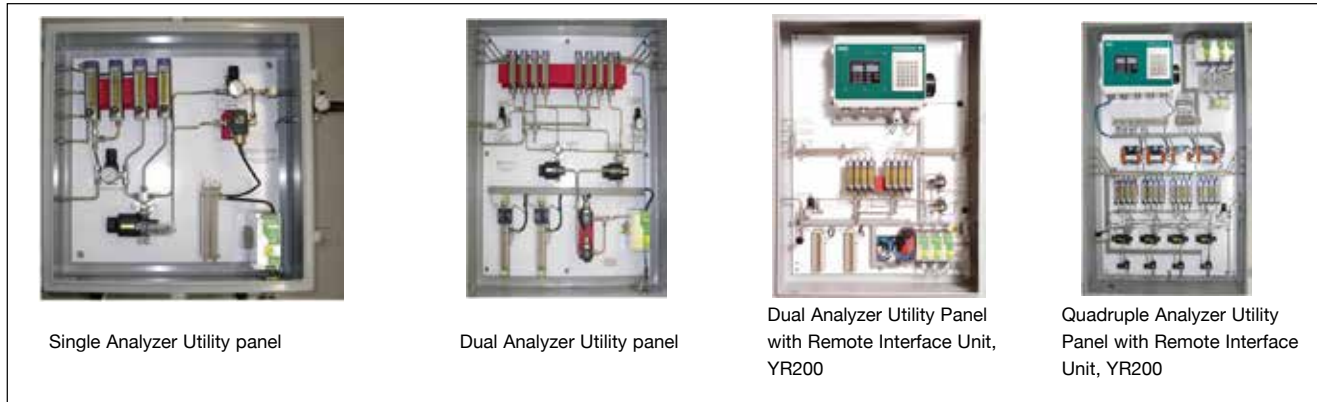

## Model and Suffix Codes

TDLS200 Utility Panel (YP200)

Base	Suffix Code	Description
YP200	-----	Utility Panel for TDLS
Number of Channels	-1 ----- -2 -----	Single Utility Panel Dual Utility Panel
Materials of Construction	-E1 ----- -E4 ----- -E2 ----- -E5 ----- -E3 ----- -E6 -----	For Single Panel, Fiberglass For Dual Panel, Fiberglass For Single Panel, Stainless Steel 316 For Dual Panel, Stainless Steel 316 For Single Panel, Stainless Steel 306 For Dual Panel, Stainless Steel 306
Materials of Back Plate Style	-A ----- -B ----- -D ----- -C -----	Painted Steel For Single Panel, Stainless Steel 316 For Dual Panel, Stainless Steel 316 For Single Panel, Stainless Steel 304
Type	-GP ----- -H2 ----- -H3 ----- -AH ----- -A2 -----	General Purpose For Single Panel, Hazardous Area (Div2) For Dual Panel, Hazardous Area (Div2) For Single Panel, ATEX Hazardous Area* For Single Fiberglass Panel, ATEX Hazardous Area*
Interface	-N ----- -R ----- -1 -----	Without RIU For Single Panel with RIU For Dual Panel with RIU
Validation Type	-MA ----- -AU ----- -A2 -----	Manual Validation For Single Panel Automatic Validation For Dual Panel Automatic Validation
-----	-N -----	Always use

\*Note: If -AH or -A2, ATEX Hazardous Area location is selected, then the RIU option is not available.

\*Note: If -AH or -A2, ATEX Hazardous Area location is selected then number of analyzers attached can only be ONE.

## Cables

The WT200 cables supplied by Yokogawa Corporation of America are compatible with all Yokogawa TDLS analyzers. The purpose of these cables is to transmit the signal from the sensor/detector to the analyzer.

The cable is either a 4 pair or 8 pair bare copper stranded conductor material covered with thermoplastic PVC. The wires are also covered with thermoplastic PVC individually and colored.

### Technical Specifications

<b>Conductor:</b>	WT200-LD: 4 Pair Shielded 18 AWG bare copper material WT200-UT: 8 Pair Shielded 18 AWG bare copper material WT200-EN: 4 Pair Shielded 24 AWG bare copper material	<b>Shield:</b>	WT200-LD: Both individual wires and overall WT200-UT: Both individual wires and overall WT200-EN: No outer shield
<b>Conductor Type:</b>	Stranded Conductor	<b>Jacket:</b>	PVC- Polyvinyl Chloride
<b>Insulation Material:</b>	WT200-LD: PVC- Polyvinyl Chloride WT200-UT: PVC- Polyvinyl Chloride WT200-EN: PO- Polyolefin	<b>Voltage:</b>	300 VAC Power Limited
		<b>Temperature Rating:</b>	WT200-LD: -30°C to 105°C WT200-UT: -30°C to 105°C WT200-EN: -20 to 75°C (installation range) -40°C to 75°C (operating range)

## Model and Suffix Codes

WT200 Cables for the TDLS

Model	Suffix Code	Description
WT200	-----	TDLS Cables
Type	-LD ----- -UT ----- -EN -----	4-Pair Tray Rated 8-Pair Tray Rated Ethernet Cable
Length	-005 ----- -010 ----- -015 ----- -020 ----- -025 ----- -030 ----- -035 ----- -040 ----- -045 ----- -050 ----- -055 ----- -060 ----- -065 ----- -070 ----- -075 ----- -080 ----- -085 ----- -090 ----- -095 ----- -100 -----	5 Meters 10 Meters 15 Meters 20 Meters 25 Meters 30 Meters 35 Meters 40 Meters 45 Meters 50 Meters 55 Meters 60 Meters 65 Meters 70 Meters 75 Meters 80 Meters 85 Meters 90 Meters 95 Meters 100 Meters
Ends	-CE ----- -US ----- -NA -----	CE End Preparations US End Preparations No End Preparations
-----	-N --	Always -N





**YOKOGAWA HEADQUARTERS**

9-32, Nakacho 2-chome,  
Musashinoshi  
Tokyo 180  
Japan  
Tel. (81)-422-52-5535  
Fax (81)-422-55-1202  
E-mail: [webinfo@mls.yokogawa.co.jp](mailto:webinfo@mls.yokogawa.co.jp)  
[www.yokogawa.com/jp](http://www.yokogawa.com/jp)

**YOKOGAWA EUROPE B.V.**

Euroweg 2  
3825 HD Amersfoort  
The Netherlands  
Tel. +31 (0)88-4641000  
Fax +31 (0)88-4641111  
E-mail: [info@nl.yokogawa.com](mailto:info@nl.yokogawa.com)  
[www.yokogawa.com/eu](http://www.yokogawa.com/eu)

**YOKOGAWA CORPORATION OF AMERICA**

2 Dart Road  
Newnan GA 30265  
United States  
Tel. (1)-770-253-7000  
Fax (1)-770-251-2088  
E-mail: [info@yca.com](mailto:info@yca.com)  
[www.yokogawa.com/us](http://www.yokogawa.com/us)

**YOKOGAWA ELECTRIC ASIA Pte. Ltd.**

5 Bedok South Road  
Singapore 469270  
Singapore  
Tel. (65)-241-9933  
Fax (65)-241-2606  
E-mail: [webinfo@yas.com.sg](mailto:webinfo@yas.com.sg)  
[www.yokogawa.com.sg](http://www.yokogawa.com.sg)

Yokogawa has an extensive sales and distribution network. Please refer to the website ([www.yokogawa.com/an/index.htm](http://www.yokogawa.com/an/index.htm)) to contact your nearest representative.



**YOKOGAWA** ◆