

General Specifications

GS 11Y01B02-01E-A

Model TDLS220
Tunable Diode Laser
Spectroscopy (TDLS) Analyzer

TDLS220
TruePeak

The TruePeak Tunable Diode Laser Spectroscopy (TDLS) Analyzer, TDLS220, is capable of measuring Oxygen in a variety of process applications with gas temperatures up to 120 °C and pressures up to 100 psig under difficult conditions (corrosive and aggressive service). The TruePeak analyzer is one of the most robust oxygen analyzers available.

Measurements are rapid (5 seconds) and interference free, offering improved accuracy when compared to other oxygen analyzers.

Typical applications include:

- Vapor Recovery Systems
- Flare and Vent Headers
- Reactor Control
- Refining
- Formaldehyde
- VCM/EDC
- IPA, TiO₂, Isocyanates, Acrylo/acetonitriles

Features

- Fast Response 5 seconds (optional 10 seconds)
- No known interference
- TruePeak measurement is capable of measuring under changing pressure with active input for live compensation. The measurement is not affected by background composition changes.
- Sample Pressures up to 100 psig
- Sample Temperature controllable up to 120°C (with heated cell option) and ambient temperature ≤ 40°C
- Optical Measurement, no sensor contact with process
- Low L_{TCO}¹ (no moving parts, high M_{TTF}² for components)
- On Board Diagnostics
- Class 1 Division 2, Group B, C, and D with purge systems

¹ Long term cost of ownership

² Mean time to failure



System Configuration

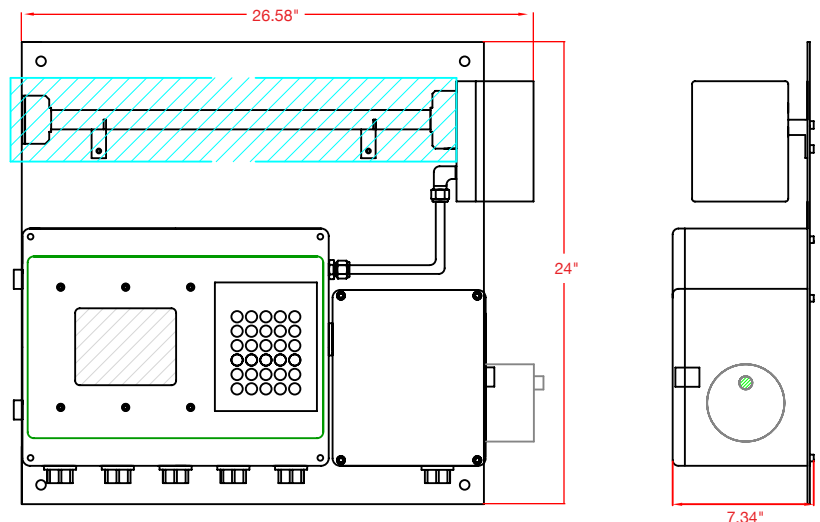
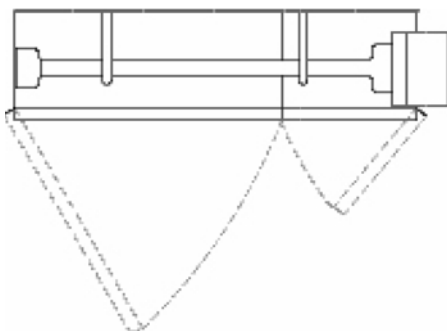

Figure 1. Dimensions

PROCESS OXYGEN ANALYSIS

The TDLS220 is specifically designed for accurate, reliable and low maintenance measurement of oxygen in process gas streams on an extractive basis.

Operational Principle

Tunable Diode Laser Spectroscopy (or TDLS) measurements are based on absorption spectroscopy. The TruePeak Analyzer is a TDLS system and operates by measuring the amount of laser light that is absorbed (lost) as it travels through the gas being measured. In the simplest form a TDLS analyzer consists of a laser that produces infrared light, optical lenses to focus the laser light through the gas to be measured and then on to a detector, the detector, and electronics that control the laser and translate the detector signal into a signal representing the gas concentration.

Gas molecules absorb light at specific wavelengths, called absorption lines. This absorption follows Beers law.

TDLS Analyzers are effectively infrared analysers which obey the Beer-Lambert Law.

$$I = I_0 \cdot e^{-E \cdot G \cdot L}$$

where I is the radiation intensity after absorption
 I_0 is the initial radiation intensity
 E is the extinction coefficient
 G is the gas concentration
 and L is the pathlength of the measurement area

Using a Tunable Diode Laser as a light source for spectroscopy has the following benefits:

- **Sensitivity:** *No known interference for Oxygen measurement*
- **Selectivity:** *The narrow line width of the laser is able to resolve single absorption lines. This provides more choices of a particular peak to use for measurement, usually allowing one isolated peak to be used.*
- **Power:** *The diode lasers has a typical power of 0.5mW.*
- **Monochromatic:** *No dispersive element (filter, etc.) required. Light source itself is selective.*
- **Tunable:** *Wavelength can be swept across the entire absorption feature; this allows resonant (peak) and non-resonant (baseline) measurement during every scan. By measuring the baseline and peak power at the detector can fluctuate rapidly by large amounts without affecting them measurement.*

Measurement

- During measurement the laser is held at a fixed temperature. This is the coarse wavelength adjustment.
- A current ramp is fed to the laser. This is the fine wavelength adjustment (figure 2).
- The current is ramped to scan across the wavelength region desired.
- The collimated light passes through the gas to be measured. The amount of light absorbed by the peak is proportional to the analyte concentration.
- The light is then focused on a detector (figure 3).
- This signal is used to quantify the light absorbed by the analyte (figure 4).

Figure 2. Current ramp to laser

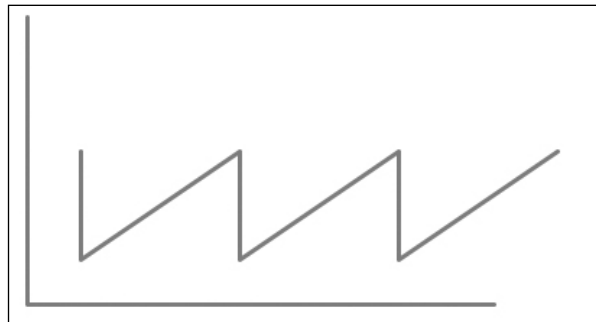

Figure 3. Signal at Detector

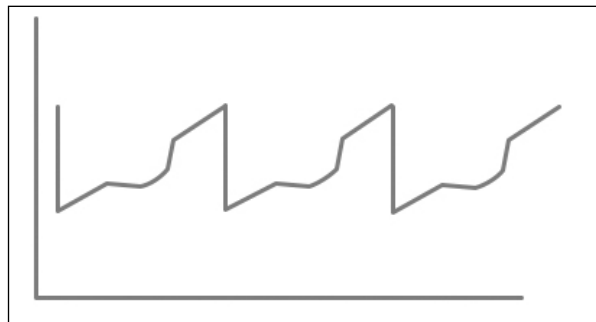
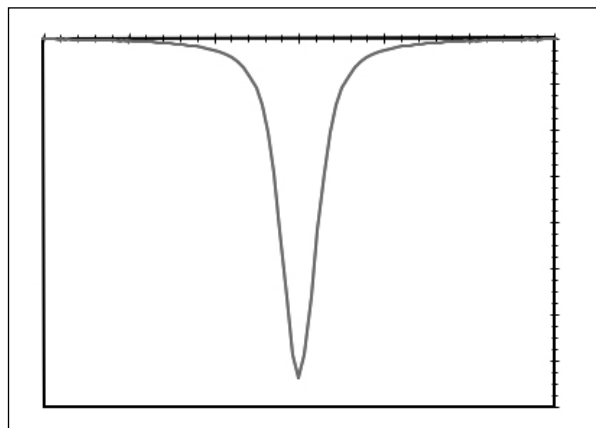

Figure 4. Processed Detector Signal



General Specifications

Measurement range:	Dependent on application. Ranges from 0-1% up to 0-25% for analysis of Oxygen.
Output signal:	(3x) 4- 20mA DC with maximum load of 900 Ohm Three isolated outputs for concentration, transmission of light and may be used for gas concentration, transmission, retransmission of data inputs or dual range 3.3 or 20mA user configurable on warnings and faults
Output Span:	Freely programmable within measuring range
Contact outputs:	(3x) configurable relays for Status (Fault, Warning, concentration level, etc.) Form C Single Pole Double Throw (SPDT) contact outputs with maximum 1A@24VDC or 0.5A@125 VAC.
Valve control:	(3x) 24VDC power supply to activate calibration solenoid valves for zero and span gas. Maximum load 1A (max 10W/ valve for zero and span gas).
Current Input:	(2x) 4-20 mA inputs for mA transmitters for pressure and temperature (Loop or lined powered).
Digital Communication:	Ethernet IEEE 802.3 10/100 mbps, RJ45 and SAK 2.5 screw terminals
Data storage:	USB1 and USB2 connection for data transfer using USB memory stick, Internal storage on CF card (result files, spectra capture, configuration data, etc.) Capture rate is configurable, typically 7-10 days of data
Warm-up time:	5 min for functioning, 60 min for full operation within specifications
Power Consumption:	80w (analyzer); with headed cell option, power consumption varies based on application (typical max 380W @ 100°C)

Environmental Specifications

Ambient Temperature:	-20 to +50 °C
Humidity:	0- 90 % RH non-condensing or 0- 100% with correct purge gas specifications
Area Classification:	The analyzer is designed for operation in General Purpose area. The addition of a Purge System facilitates operation in Hazardous Area for gaseous releases. Class 1 Division 2 Group B, C and D (ATEX/CE Pending) (Optional) CSA $\frac{C}{U}$ Special Acceptance certification.
Weather resistance:	IP65 which is equivalent to NEMA 4X
Cable entries:	$\frac{3}{4}$ " FNPT threads (unused holes are plugged)
Gas Connections:	Analyzer - $\frac{1}{4}$ " welded Swagelok® connection
Enclosures:	Die Cast copper free Aluminum grade AL SI 12 with a powder coat exterior finish. The alloy is particularly resistant to salt atmosphere, Sulfur gases and galvanic corrosion Stainless Steel captive screws and optional keypad. Laminated Safety Glass for optional display(s)
Sample Gas Temperature:	Maximum 120°C, with ambient temperature $\leq 40^\circ\text{C}$. Maximum 100°C with ambient temperature $\leq 50^\circ\text{C}$
Sample Gas Pressure:	Maximum 100 psig
Mounting:	Wall, 24" x 24" plate 316L Stainless back plate Size: W x H x D 750mm x 600mm x 200mm (30" x 24" x 10")
Weights:	approx: 67lbs., 30.4kg
Note:	Each application may differ in maximum limitations depending upon the combination of gas temperature, gas pressure, and concentration of gas being measured.

Performance specification

Precision*	0.01% O ₂
Linearity*	Typically R2 > 0.999
Response time	5 or 10 seconds plus transport time to analyzer
Drift*	Span drift (6-12 month calibration) <+/- 0.1% O ₂ Zero drift (6-12 month Calibration) <+/- 0.05% O ₂
Analog I/O (Optional)	Outputs: Concentration/Transmission (3@ 4-20mA isolated) Sub 4mA for warnings/faults Inputs: Pressure/Temperature Feed for Compensation (2@ 4-20mA isolated, powered or loop power)
Digital I/O	Outputs: Warning/Fault/Concentration Limit Relays (3 Form C Relay SPDT rated 1A@ 24VDC) • Valve Control (3@ 24VDC, Max 10W per valve), zero/span • Inputs: Remote Validation (3 voltage free floating contacts) for zero/span
Communications	Ethernet, IEEE 802.3, 10/100 Mbps, RJ45 Automatic USB data transfer (upload/download settings and data)
Calibration	Recommended Calibration Check Interval 3-6 Months
Gas Sampling Conditions	The extracted sample should be typically filtered, clean and dry (non-condensing) Cell volume = 260 cc Flow rate of 1~20L/min, typically 6 L/min Pressure of -3 psig to 100 psig Temperature of -20°C(4°F) to 50°C (122°F) un-heated or 120°C (248°F) heated
Gas Measured*	O ₂ : 0.01% detection limit, Min Range 0-1%, Max range 25%

Performance Specifications are application dependant.

*Consult Yokogawa for ranges; All performance specifications are for 25°C at 1 bar.

Installation Specifications

By Design: The analyzer is designed for operation in General Purpose area. The addition of a Purge System facilitates operation in Hazardous Area for gaseous releases. Class 1 Division 2 Group B, C and D (ATEX/CE Pending) (Optional) CSA  Special Acceptance certification.

Flow Cell Wetted Parts

Standard: 316L, Sapphire windows, Teflon encapsulated Viton O-rings, and protected gold mirror
Optional: Monel Alloy 400, Kalrez 4079 O-rings

Integration

Configuration

- Sample is fully extracted from process (and should be conditioned before measurement)
- Process pressure and temperature can be controlled or the analyzer may require pressure and temperature inputs (application dependant)
- Length of flow cell is fixed

Purge Gas & Validation

Available systems (standard or custom) for:

- Manual or Automatic Validation
- Manual or Automatic Calibration
- Manual or Automatic Stream Switch
- Analyzer purge gas control
- Other options Available

Display and Software Functions:

TruePeak software has multiple levels, the default (or start page) is the Main Menu:

Main Menu Displays:

Gas Concentration
Transmission %
Status (warm-up, OK, Warning, Fault, etc.)
Temperature (Fixed, Active Ambient or Active)
Pressure (Fixed or Active)

Main Menu:

Basic Menu

Configure, 3 functions
View Spectra, 2 functions
Data, 3 sub-menus
Trends

Advanced Menu:

Configure, 9 sub-menus (User Password)
Calibrate & Validate, 3 sub-menus
Data, 4 sub-menus
Trends

Active Alarms:

List of active alarms

Shut Down Analyzer:

Instructions to close TruePeak local or VAC

Calibration Functions:

Off-line Calibrations:

Zero calibration
Zero off-set
Span calibration
Transmission

Off-line Validations:

Check gas #1
Check gas #2
Check gas #3

On-Line Validations:

Manual
Automatic

Setup Functions:

Configuration:
Process Path Length
Pressure
Temperature
Units
System I/O
System
Valve Control
Laser Spectra & Control

Diagnostics:

Warnings include:

Detector signal low
Transmission low
Spectrum noise high
Process pressure out of range
Process temperature out of range
Concentration out of range
Board temperature out of range
Validation failure

Faults include:

Laser temperature out of range
Detector signal high
Detector signal lost
Peak center out of range

Output Settings:

Analog Output:

Channel 1
Channel 2
Channel 3
Warning Mode
Fault Mode
Field Loop Check
AO CH calibration

User Interface

1. Local Analyzer Interface:

Basic Unit (Blind)

No local interface built-in. USB port is provided for data transfer. To configure, start-up and service the analyzer, user must use the supplied VNC viewer software.

Mini-Display

A 4 line 20 character (4x20) vacuum florescent display (VFD) built in to the door. It will display measurement concentration, Transmission, scrolling Status (including alarm types) and scrolling system information (including process parameters). USB port is provided for data transfer. To configure, start-up and service the analyzer, user must use the supplied VNC viewer software.

Screen & Keypad

A 30 key stainless steel keypad and 6.5" graphical LCD panel built in to the door. This provides full local interface. It eliminates the need for a PC/laptop or (RIU) Remote Interface Units. USB port is provided for data transfer.

2. Remote Interface Unit (RIU):

Use with any type of analyzer, a separate wall mount enclosure with screen and keypad. Connects via Ethernet (VNC), up to 3 (standard) 8 (on request) analyzers. Requires 24 VDC input power

- Wall mount enclosure, IP65 (NEMA 4) powder coated aluminum
- Approx 460x330x180mm (18"w x 13"h x 7"d) weight 11.5kg (25lbs)
- Purged for ATEX CAT 2G or CAT 3G, CE, NEC Cl.1, BCD, Division 1 or 2
- Requires 23.5 - 24.5VDC Input power
- Integral keypad and 6.5" display
- Accepts 8 analyzer Ethernet connections – Standard
Accepts more analyzer Ethernet connections – On request
- Connection to Analyzer Unit via 8 pair shielded twisted pair cable.

TruePeak Virtual Analyzer Controller (VAC) software included, running Window XP embedded OS.

Model And Suffix Code YR200 Remote Interface Unit for TDLS

Model	Suffix	Description
YR200	-----	Remote Interface Unit
Type	-G1 ----- -D2 ----- -A1 -----	General Purpose Hazardous Area Div 2 Hazardous Area ATEX
-----	-N ---	Always N

Model and Suffix Codes

Model TDLS220

Tunable Diode Laser Gas Analyzer

Model	Suffix	Option	Description
TDLS220	-----	-----	Tunable Diode Laser
Type	-G1-----	-----	General Purpose
	-D2-----	-----	NEC Class 1 Div 2 BCD
	-K1-----	-----	CSA [†] Special acceptance certification for general purpose
	-K2-----	-----	CSA [†] acceptance certification for Class 1 Div 2
	-X1-----	-----	Basic O2: 0-1% up to 0-25% oxygen
	-S6-----	-----	Stainless Steel 316L back plate
	-SST-----	-----	316L flow cell, sapphire windows and teflon encasulated viton o-rings
	-SSK-----	-----	316L flow cell, sapphire windows and Kalrez o-rings
	-MSK-----	-----	Monel A400 flow cell, sapphire windows and Kalrez o-rings
	-SSX-----	-----	316L flow cell, sapphire windows and Kalrez 6375 o-rings
	-MSX-----	-----	Monel A400 flow cell, sapphire windows and Kalrez 6375 o-rings
	-TC-----	-----	No Heat, Temp sensor/ insulation jacket (Active T.comp)
	-GP-----	-----	General Purpose/Safe Area cell heating, max 120°C - Insulated Jacket
	-CE-----	-----	General Purpose/Safe Area cell heating, max 100°C - Insulated Jacket
	-D2-----	-----	Div. 2 cell heating, 120°C-Insulated Jacket
		-N---	Blind Controller
		-1---	Integral Mini Display
		-2---	Integral Color LCD Backlit
Options		/U---	Ext. USB Port IP66 w/cap (can be used with general purpose, safe area, only)

NOTE: Select *an* item from each section.
Example: TDLS220-G1-X1-S6-SST-GP-1/U

Please Note: If sample conditioning is existing or to be provided by other, then complete information below based on conditions at the analyzer.

If sample conditioning is to be provided with the TDLS220, then complete the information below based on conditions at the process take-off point.

Customer Name, plant location, process type and/or project name				
Tag Number:				
Sample Handling:		Existing/By Others (Analyzer in-let conditions)		Required With TDLS220 (Process take-off Conditions)
Gas Temperature Specify units Supplied to Analyzer	Units	Min	Norm	Max
Gas Supply Pressure Specify units Supplied to Analyzer	Units	Min	Norm	Max
Gas Return Pressure	Units	Min	Norm	Max
Oxygen Concentration		Min	Norm	Max
Monitor or Control?			Norm	Max
Alarm Level			Norm	Max
Action Level			Norm	Max
Gas Stream Composition				
Special Wetted Materials – if any				
Area Classification				
Application Comments				

YOKOGAWA HEADQUARTERS
 9-32, Nakacho 2-chome,
 Musashinoshi
 Tokyo 180
 Japan
 Tel. (81)-422-52-5535
 Fax (81)-422-55-1202
 E-mail: webinfo@mls.yokogawa.co.jp
www.yokogawa.com.jp

YOKOGAWA EUROPE B.V.
 Databankweg 20
 3821 AL Amersfoort
 The Netherlands
 Tel. +31-33-4641 611
 Fax +31-33-4641 610
 E-mail: info@nl.yokogawa.com
www.yokogawa.com/eu

YOKOGAWA CORPORATION OF AMERICA
 2 Dart Road
 Newnan GA 30265
 United States
 Tel. (1)-770-253-7000
 Fax (1)-770-251-2088
 E-mail: info@yca.com
www.yokogawa.com/us

YOKOGAWA ELECTRIC ASIA Pte. Ltd.
 5 Bedok South Road
 Singapore 469270
 Singapore
 Tel. (65)-241-9933
 Fax (65)-241-2606
 E-mail: webinfo@yas.com.sg
www.yokogawa.com.sg

Yokogawa has an extensive sales and distribution network. Please refer to the website (www.yokogawa.com) to contact your nearest representative.



YOKOGAWA ◆