

InfraSpec NR800



# FT-NIR Analyzer InfraSpec NR800

Bulletin12Y03A03-01E

[www.yokogawa.com/an/](http://www.yokogawa.com/an/)

**vigilantplant.**<sup>®</sup>  
The clear path to operational excellence

**YOKOGAWA** 



## NR800 The New FT-NIR from Yokogawa

The new Yokogawa NR800 is an FT-NIR analyzer offering unparalleled reliability and stability for a wide range of process and laboratory applications. Its high wavelength resolution, outstanding accuracy and wide scanning range deliver a new level of process information, opening up new possibilities. Direct transfer of a calibration model from the laboratory to the process, or among processes, is also possible. And of course, ease of operation and user-friendly software are key design concepts of the NR800.

The NR800 FT-NIR from Yokogawa is based on over 50 years of R&D in analyzer systems especially spectrometers and sensing devices, and application experience gained as the leading supplier of process measurement and control systems.

### Features

#### Stability and reliability

In addition to the well-known features of FT-NIR of high throughput and quick response time, the NR800 employs a newly-developed Michelson interferometer with vibration-resistant mechanism that ensures even more reliable and stable operation. Unlike other FT-NIR systems, the NR800 runs without a PC as a completely stand-alone system for on-line measurement. Analyzer operations cannot be interrupted by a PC failure nor be affected by rapid changes in PC technology.

#### ● Interferometer without mechanical abrasion

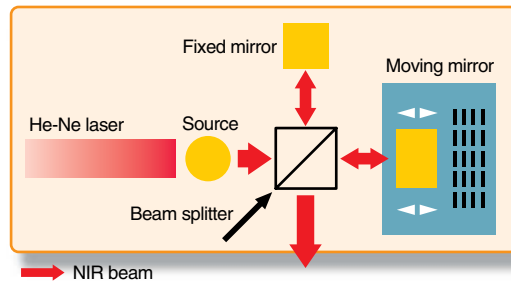

#### Single detector throughout the wavelength range

The measurement wavelength range of the NR800 is from 900 nm to 2500 nm, revealing new information and offering a more accurate calibration model. A single detector InGaAs is used throughout the scanning range.



Wide-range InGaAs Detector



#### High resolution

The wavelength resolution of the NR800 is from  $4\text{cm}^{-1}$ . A best-fit band can be used for calibration models and measurement. High resolution is especially useful for foodstuff and pharmaceutical applications.

#### Calibration model transfer

Laboratory models can be applied directly to systems on the process stream, model transfer between analyzers can also be done. It realize "seamless" transition from laboratory to process.

#### Up to 4 multi-stream channels with no moving parts

The NR800 provides up to 4 channels for multiple spectrometers. Channel switching is done electrically and no mechanical moving parts are used, thus ensuring maximum reliability and fast response.

#### First-hand Experience

In 1993, Yokogawa released the NR500 as the first FT-NIR for process monitoring, most parts of which such as the interferometer were specially designed from scratch for process use. The NR800 inherits the same design concept as well as field experience, and various improvements and additions have been made.

## Easy Operation and User-friendly Software

Good hardware may not always deliver good results or its full potential if it is difficult to use or the application software is inappropriate. The NR800 offers simple operation in the field in addition to a user-friendly software environment and powerful tools for engineering, maintenance and data management.

### SPECTLAND 2 process (on-line) monitoring software

Unmanned operation is the rule for process monitoring, simple operation for engineering and maintenance. SPECTLAND 2 is a measurement and control software package for the NR800 that offers both. After making a few simple settings such as component No. and stream No., no further intervention is needed. But SPECTLAND 2 also provides a Windows-based\*1 engineering and maintenance environment and tools.

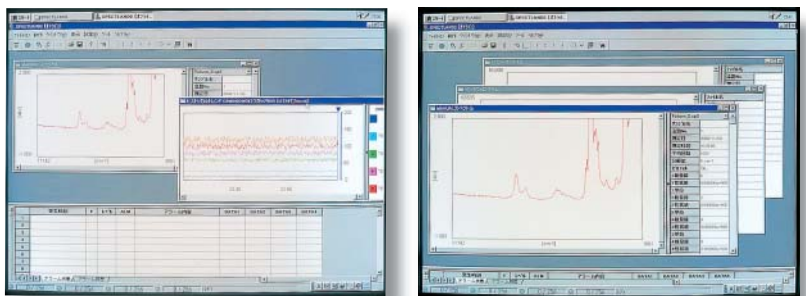

### The Unscrambler®\*2 advanced chemometrics software

The engine of calibration model generation and validation in the NR800 is the well-known "the Unscrambler®." From spectrum data processing to regression analysis tools such as MLR, PCA, PCR, PLS, as well as statistical analysis, the Unscrambler® offers a powerful environment and tools for all phases from calibration model generation to validation. Data/file transfer between SPECTLAND 2 and the Unscrambler® is done using simple Windows operations.

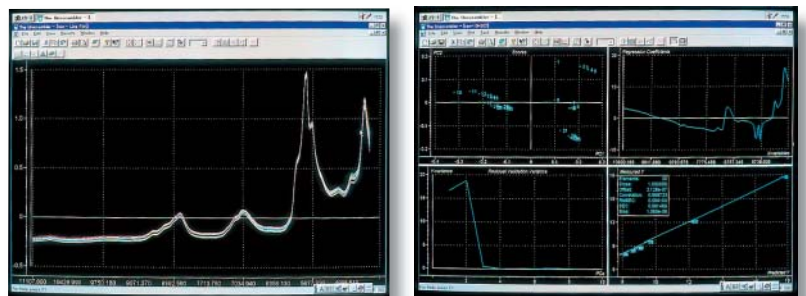

### Laboratory operation software

Some laboratory applications have unique requirements. Operation and analysis software specially tailored for handling such requirements is now being developed and will be integrated with SPECTLAND 2.

\*1: Windows is a registered trademark of Microsoft Corporation, U.S.A.

\*2: The Unscrambler® is a registered trademark of Camo AS, Norway.

## FT-NIR - Rapid, multi-component, non-destructive

A near-infrared beam from the light source is first introduced to the interferometer to create an interferogram. This interferogram is applied to the sample, which then absorbs a specific band (wavelength) of light unique to the functional groups of the sample. The absorbance information is applied to a calibration curve prepared in advance, and concentration and properties are then calculated from the curve. The calibration model is prepared by inputting sample spectrum measurement data and conventional laboratory analysis results into the chemometrics (multivariate analysis) software.

### Measurement principle

AO	←	Comp. A :15.0%
DO	←	Comp. B : 0.2%
RS422	←	Comp. C : 0.5%

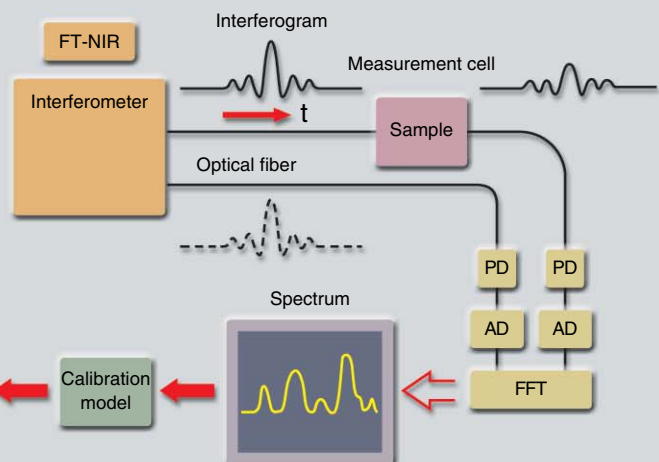

## Full Range of Solutions to Any Situation

From hardware supply to maintenance support, Yokogawa offers a wide range of products and services to address the customer's precise needs.

### Example of on-line monitoring system

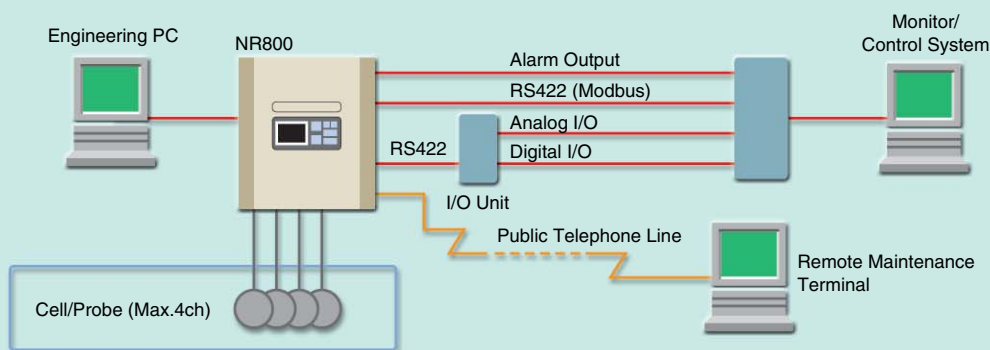

### NR800 for on-line (process) monitoring

For process applications, both general-purpose and explosion-proof models are available. Multi-channel switching of up to 4 channels is performed with no mechanical moving parts. An external stream switcher for up to 16 streams is available as an option.



### Flow cells and probes

As the "heart" of the analyzer, various flow cells and probes are available to suit various applications.

- Flow-through type cell
- Temperature-controlled flow-through cell
- In-situ probes
- Diffuse reflectance accessory

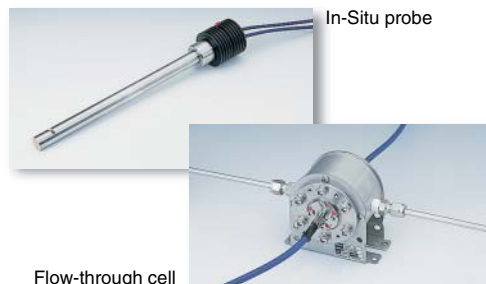

### External interfaces

- Modbus on RS422 communication
- Analog output (4-20 mA): Max. 40
- Analog input (1-5V DC): Max. 4
- Alarm output from analyzer: Max. 2
- Digital output: Max. 12
- Digital input: Max. 12
- Engineering PC interface
- Sampling system interface
- Remote maintenance interface

### Optical fiber

- Single beam
- Double beam
- Fluoride fiber



## Sample handling system

The sample handling system is a crucial part of analysis. Yokogawa provides the most appropriate, cost-effective sample handling system based on its wealth of know-how and experience.

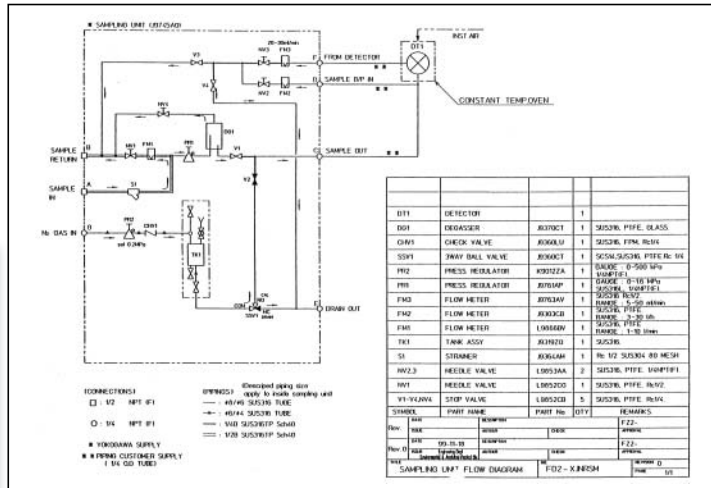

## Remote maintenance support

Yokogawa's centralized service center can directly communicate with the system located at the customer's site. From system diagnostics and troubleshooting to improvement of calibration models, Yokogawa's service center can remotely perform those tasks that used to be done at site. This service drastically cuts downtime and maintenance cost, and improves production efficiency.



## Laboratory model

A desktop laboratory model of the NR800 is available, and either fiber connection or open beam type can be selected as required. Various attachments and accessories are available.

### Accessories and attachments

- Cuvette holder
- Vial holder
- Diffuse reflectance accessories
- Auto-sampler
- Constant temperature water circulation unit



Auto-Sampler

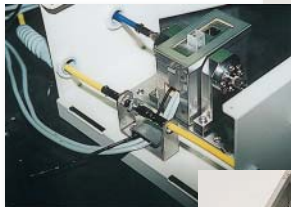

Temp. Controlled Cuvette Holder

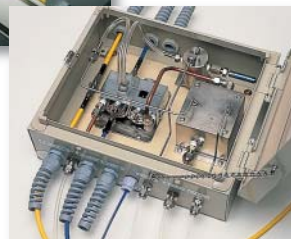

Cuvette Holder with water-circulation



InfraSpec  
NR800

## We Breathe Life into Hardware

Application engineering is essential for successful installation of FT-NIR. From measurement of gasoline properties to LSI Fab applications, and from process to laboratory, Yokogawa application engineering makes our hardware come alive and work for you.



### Refinery: Reduction of give away and production cost

- Off site application (RON, MON, RVP, Dist. Aroma. Dens., etc.)
- On site application (RON, MON, RVP, Dist. Aroma. Dens. etc.)

### LSI and LCD: Improvement of production yield

- Recovery of photo-resist solvent
- Remover concentration
- Moisture content in washing liquor
- Solvent concentration
- Washing liquor concentration

### Chemicals: Reduction of production cost and production optimization

- Acid Value, OHV, IV, function group analyses, viscosity, additive quantity, molecular weight, residual monomer quantity, moisture, etc. for polymers and monomers such as polyol, PP, PET, EP, PE, PVA, MMA, SBS, and PS
- Chemical concentration ● Solvent concentration
- Water contents

### Food & Pharmaceutical: QC and reduction of production cost

- Dairy products: FAT, SNF, protein, etc.
- Fermented milk: Fermentation degree
- Vinegar: Acid concentration
- Beer, liquor: Alcohol content
- Food in general: Acid, OHV, amino acid, TN
- Bulk materials: Moisture, FAT, sugar, etc.
- Soya source: Salt content
- Residual solvent concentration in pharmaceuticals
- Other on-line monitoring for pharmaceuticals

### Pulp & Paper: Improvement of operation

- Total/effective alkali in black liquor in digester
- Total/effective alkali in green and white liquor in recovery
- Concentration of other chemicals

### Others:

- Water content in electrolyte in Li-battery production
- Organic silicon content

# A Single Source Supplier

Throughout the life of an analyzer project from the feasibility study to post-installation support, and for all sizes of project from single analyzer hardware to complete analyzer package systems, Yokogawa acts as a single source supplier. And of course, Yokogawa offers total systems integration with its process control and measurement systems.

## Related Services

From sample testing and feasibility studies to calibration model generation and validation/evaluation, Yokogawa offers all related services to place NIR on-stream.

- Sample testing and feasibility studies for measurement
- Calibration model generation
- Calibration model generation support (on-site/classroom)
- Validation and evaluation of calibration model
- Chemometrics classroom lecture and hands-on practice
- Customized training course

## Systems Integration

From initial design to post-installation support, Yokogawa serves as a single source supplier and assumes total system responsibility for all analytical and control systems requirements. Beginning with process flow sheets, Yokogawa can act as your subcontractor for all analytical systems. As a leading supplier of process analyzers, Yokogawa is fully conversant with application, sampling, installation, performance and maintenance. Yokogawa has decades of experience in providing a complete analytical systems package for each customer's specific requirements.

- Design and manufacturing of sample handling systems
- Front-end engineering, design and manufacturing of complete analyzer packages
- Analyzer systems integration
- Overall project management



## Post-installation Support

To assure the continued high level of performance designed into every Yokogawa product, Yokogawa maintains a comprehensive network of service centers which provide efficient and professional service whenever and wherever needed. Systems start-up, routine maintenance, emergency services or contracted periodic maintenance are all available from Yokogawa. Our unique Remote Maintenance Support service is also available as an option, which drastically cuts system downtime.

## SPECIFICATIONS

### Analyzer

Item	Description
Principle	Fourier-transform Near Infrared analyzer via fiber-optic cable, Double or Single beam
Wavelength range	900-2500 nm or 900-2100 nm
Wavelength accuracy	0.04 cm <sup>-1</sup>
Wavelength repeatability	0.007 cm <sup>-1</sup>
Wavelength resolution	4, 8, 16, 32, 64 cm <sup>-1</sup> selectable
No. of channel	Max. 4 channels with no optical multiplexers
No. of measurement	Max.12 per channel (Max.64 per analyzer )
Measurement time	4 seconds as minimum(depending on the number of averaging and measuring channels, as well as measurement items)
Communication interface	RS422(Modbus); 2 channels (DCS, IO unit) Ethernet ; 1 channel (Engineering PC)
Contact output	System alarm ; 1, Annunciator ; 1 (Explosion-proof model) Power fail ; 1, System alarm ; 1 (General purpose model)
Enclosure	General purpose Model NR801AG ; English version Model NR801EG ; With CE mark Model NR801JG ; Japanese version Explosion-proof Model NR805AG ; FM approved or CSA approved. Type X purging and explosion-proof for Class I, Division 1, Groups B, C and D. Temperature Class T5. Model NR805EG ; ATEX(KEMA)certified. KEMA 02ATEX2175, II 2G, EEx pd IIB +H2 T5 Model NR805JG ; TIIS certified, Suitable for TIIS Ex pd IIB+H2 T5 X
Power supply	100, 115 , 200 or 230 VAC ±10%, 50/60 Hz ±2Hz; consumption: Approx. 250 VA
Environment temp., RH	-10 to 40 °C, 0 to 95 %RH
Weight	General-purpose model : Approx. 50kg Explosion-proof model : Approx. 65kg

### IO Unit

Item	Description
Model name	NR893AG(to be used with NR801,805AG) NR893EG, With CE mark NR893JG(to be used with NR801,805JG)
Location	Non-hazardous area, indoor.
No. of analog output	0,4,8,12,16,20,24,28,32,36 or 40
No. of contact output	I/O unit failure; 1, Communication failure; 1, Operating Mode; 5, Outlier; 4
AC power supply	100, 115 , 200 or 230 V AC ±10%, 50/60 Hz ; consumption: Approx. 100 VA
DC power supply for analog output	24VDC±10%, consumption; Approx. 200mA/4 points
Environment temp., RH	5 to 35 °C, 0 to 95 %RH
Weight	Approx. 10 kg
Mounting	Wall mounting

## DIMENSIONS

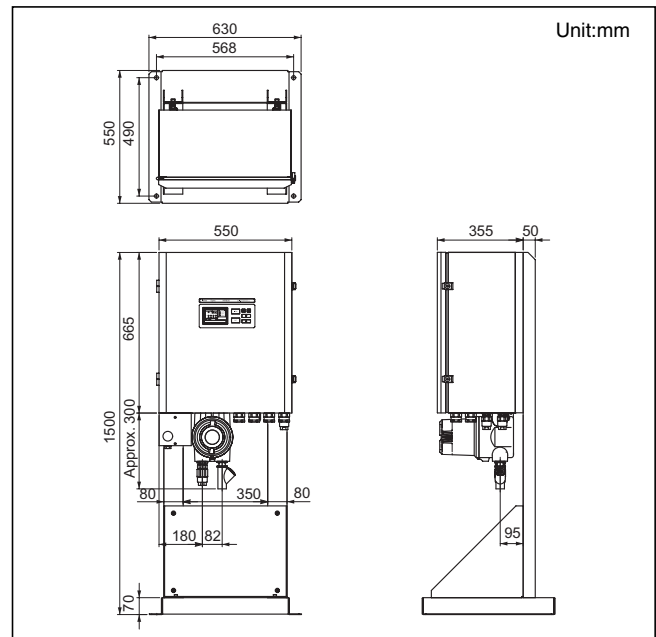

DWG for Explosion-proof type with free standing rack

**vigilantplant.**<sup>®</sup>

The clear path to operational excellence

SEE  
CLEARLY

KNOW  
IN ADVANCE

ACT  
WITH AGILITY

VigilantPlant is Yokogawa's automation concept for safe, reliable, and profitable plant operations. VigilantPlant aims to enable an ongoing state of Operational Excellence where plant personnel are watchful and attentive, well-informed, and ready to take actions that optimize plant and business performance.

**YOKOGAWA ELECTRIC CORPORATION**  
World Headquarters  
9-32 Nakacho 2-chome, Musashino-shi,  
Tokyo 180-8750, JAPAN  
Tel: +81-422-52-6316 Fax: +81-422-52-6619  
<http://www.yokogawa.com/an/>

**North America**  
**YOKOGAWA CORPORATION OF AMERICA**  
Georgia, U.S.A  
<http://www.yokogawa.com/us/>

**South America**  
**YOKOGAWA AMERICA DO SUL LTDA.**  
BRAZIL  
<http://www.yokogawa.com.br/>

**Europe**  
**YOKOGAWA EUROPE B.V.**  
European Headquarters  
THE NETHERLANDS  
<http://www.yokogawa.com/eu/>  
**YOKOGAWA ELECTRIC CIS LTD.**  
RUSSIAN FEDERATION  
<http://www.yokogawa.ru/>

**Middle East**  
**YOKOGAWA MIDDLE EAST B.S.C.(C)**  
<http://www.yokogawa.com/bh/>  
**Singapore**  
**YOKOGAWA ENGINEERING ASIA PTE. LTD.**  
<http://www.yokogawa.com/sg/>

**Korea**  
**YOKOGAWA ELECTRIC KOREA CO., LTD.**  
<http://www.yokogawa.com/kr/>

**China**  
**YOKOGAWA CHINA CO., LTD.**  
<http://www.yokogawa.com/cn/>  
**YOKOGAWA SHANGHAI INSTRUMENTATION CO., LTD.**  
<http://www.ysi.com.cn/>  
**YOKOGAWA SICHUAN INSTRUMENT CO., LTD.**  
<http://www.cys.com.cn/>

**Taiwan**  
**YOKOGAWA TAIWAN CORPORATION**  
<http://www.yokogawa.com.tw/>

**India**  
**YOKOGAWA INDIA LTD.**  
<http://www.yokogawa.com/in/>  
**Australia**  
**YOKOGAWA AUSTRALIA PTY. LTD.**  
<http://www.yokogawa.com/au/>

Represented by:

Vig-PMK-G-NL-10E

Printed in Japan, 209(KP) [Ed : 01/b]