

### Scope of application

- Precise flow rate measurement of fluids and gases, multi-phase media and media with specific gas content using the Coriolis principle.
- Direct measurement of mass flow and density independent of the medium's physical properties, such as density, viscosity and homogeneity
- Concentration measurement of solutions, suspensions and emulsions
- Medium temperatures of  $-70 - 200\text{ }^{\circ}\text{C}$  ( $-94 - 392\text{ }^{\circ}\text{F}$ )
- Process pressures up to 100 bar
- EN, ASME, JPI or JIS standard flange process connections up to three nominal diameters per meter size
- Connection to common process control systems, such as via HART7 or Modbus
- Hazardous area approvals: IECEx, ATEX, FM (USA/Canada), NEPSI, INMETRO, PESO
- Safety-related applications: PED per AD 2000 Code, SIL 2, secondary containment up to 59 bar
- Marine type approval: DNV GL

### Advantages and benefits

- Inline measurement of several process variables, such as mass, density and temperature
- Adapterless installation due to multi-size flange concept
- No straight pipe runs at inlet or outlet required
- Fast and uncomplicated commissioning and operation of the flow meter
- Maintenance-free operation
- Functions that can be activated subsequently (feature on demand)
- Total health check: Self-monitoring of the entire flow meter, including accuracy
- Maximum accuracy due to calibration facility accredited according to ISO/IEC 17025 (for option K5)
- Self-draining installation
- Vibration-resistant due to counterbalanced double-tube measurement system

## Table of contents

<b>1</b>	<b>Introduction</b>	<b>5</b>
1.1	Applicable documents	5
1.2	Product overview	6
<b>2</b>	<b>Measuring principle and flow meter design</b>	<b>7</b>
2.1	Measuring principle	7
2.2	Flow meter	9
<b>3</b>	<b>Application and measuring ranges</b>	<b>12</b>
3.1	Measured quantities	12
3.2	Measuring range overview	12
3.3	Mass flow	13
3.4	Volume flow	13
3.5	Pressure loss	13
3.6	Density	13
3.7	Temperature	14
<b>4</b>	<b>Accuracy</b>	<b>15</b>
4.1	Overview	15
4.2	Zero point stability of the mass flow	16
4.3	Mass flow accuracy	16
4.3.1	Sample calculation for liquids	17
4.3.2	Sample calculation for gases	18
4.4	Accuracy of density	19
4.4.1	For liquids	19
4.4.2	For gases	19
4.5	Accuracy of mass flow and density according to the MS code	20
4.5.1	For liquids	20
4.5.2	For gases	20
4.6	Volume flow accuracy	21
4.6.1	For liquids	21
4.6.2	For gases	21
4.7	Accuracy of temperature	22
4.8	Repeatability	22
4.9	Calibration conditions	23
4.9.1	Mass flow calibration and density adjustment	23
4.9.2	Density calibration	23
4.10	Process pressure effect	23
4.11	Process temperature effect	24
<b>5</b>	<b>Operating conditions</b>	<b>25</b>
5.1	Location and position of installation	25
5.1.1	Sensor installation position	25
5.2	Installation instructions	26
5.3	Process conditions	26
5.3.1	Medium temperature range	26
5.3.2	Density	27
5.3.3	Pressure	27

5.3.4	Effect of temperature on accuracy .....	29
5.3.5	Secondary containment .....	30
5.4	Ambient conditions .....	30
5.4.1	Allowed ambient temperature for sensor .....	31
5.4.2	Temperature specification in hazardous areas .....	32
<b>6</b>	<b>Mechanical specification .....</b>	<b>37</b>
6.1	Design.....	37
6.2	Material.....	38
6.2.1	Material wetted parts.....	38
6.2.2	Non-wetted parts.....	38
6.3	Process connections, dimensions and weights of sensor .....	39
6.4	Transmitter dimensions and weights .....	46
<b>7</b>	<b>Transmitter specification.....</b>	<b>48</b>
7.1	Inputs and outputs .....	49
7.1.1	Output signals .....	50
7.1.2	Input signals.....	56
7.2	Power supply .....	57
7.3	Cable specification.....	57
<b>8</b>	<b>Approvals and declarations of conformity .....</b>	<b>58</b>
<b>9</b>	<b>Ordering information.....</b>	<b>64</b>
9.1	Overview MS code Prime 25 .....	64
9.2	Overview MS code Prime 40 .....	67
9.3	Overview MS code Prime 50 .....	70
9.4	Overview MS code Prime 80 .....	73
9.5	Overview options .....	76
9.6	MS code.....	81
9.6.1	Transmitter .....	81
9.6.2	Sensor.....	81
9.6.3	Meter size .....	82
9.6.4	Material wetted parts.....	82
9.6.5	Process connection size .....	82
9.6.6	Process connection type.....	83
9.6.7	Sensor housing material .....	83
9.6.8	Medium temperature range.....	83
9.6.9	Mass flow and density accuracy .....	84
9.6.10	Design and housing .....	85
9.6.11	Ex approval .....	86
9.6.12	Cable entries.....	86
9.6.13	Inputs and outputs .....	86
9.6.14	Display .....	88
9.7	Options .....	89
9.7.1	Connecting cable type and length.....	89
9.7.2	Additional nameplate information.....	90
9.7.3	Presetting of customer parameters .....	90
9.7.4	Concentration and petroleum measurement.....	90
9.7.5	Expanded process temperature (Ex) .....	92

## Table of contents

---

9.7.6	Certificates .....	92
9.7.7	Country-specific delivery .....	94
9.7.8	Tube health check.....	95
9.7.9	Transmitter housing rotated 180° .....	95
9.7.10	Measurement of heat quantity .....	95
9.7.11	Marine Approval .....	96
9.7.12	Customer specific special product manufacture .....	96
9.8	Ordering Instructions .....	97

# 1 Introduction

---

## 1.1 Applicable documents

---

For Ex approval specification, refer to the following documents:

- Ex instruction manual ATEX IM 01U10X01-00\_ \_-R
- Ex instruction manual IECEX IM 01U10X02-00\_ \_-R
- Ex instruction manual FM IM 01U10X03-00\_ \_-R
- Ex instruction manual INMETRO IM 01U10X04-00\_ \_-R
- Ex instruction manual PESO IM 01U10X05-00\_ \_-R

Other applicable User's manuals:







- Protection of Environment (Use in China only) IM 01A01B01-00ZH-R

## 1.2 Product overview

Rotamass Coriolis flow meters are available in various product families distinguished by their applications. Each product family includes several product alternatives and additional device options that can be selected.

The following overview serves as a guide for selecting products.

**Overview of Rotamass product families**

<p>Rotamass Nano</p>		<p><b>For low flow rate applications</b>                  Meter sizes: Nano 06, Nano 08, Nano 10, Nano 15, Nano 20                  Connection sizes:  <ul style="list-style-type: none"> <li>▪ DN15, DN25, DN40</li> <li>▪ 1/4", 1/2", 3/8", 3/4", 1", 1 1/2"</li> </ul>                 Maximum mass flow: 1.5 t/h (55 lb/min)</p>
<p>Rotamass Prime</p>		<p><b>Versatility with low costs for the operator</b>                  Meter sizes: Prime 25, Prime 40, Prime 50, Prime 80                  Connection sizes:  <ul style="list-style-type: none"> <li>▪ DN15, DN25, DN40, DN50, DN80</li> <li>▪ 3/8", 1/2", 3/4", 1", 1 1/2", 2", 2 1/2", 3"</li> </ul>                 Maximum mass flow: 76 t/h (2800 lb/min)</p>
<p>Rotamass Supreme</p>		<p><b>Excellent performance under demanding conditions</b>                  Meter sizes: Supreme 34, Supreme 36, Supreme 38, Supreme 39                  Connection sizes:  <ul style="list-style-type: none"> <li>▪ DN15, DN25, DN40, DN50, DN80, DN100, DN125</li> <li>▪ 3/8", 1/2", 3/4", 1", 1 1/2", 2", 2 1/2", 3", 4", 5"</li> </ul>                 Maximum mass flow: 170 t/h (6200 lb/min)</p>
<p>Rotamass Intense</p>		<p><b>For high process pressure applications</b>                  Meter sizes: Intense 34, Intense 36, Intense 38                  Connection sizes:  <ul style="list-style-type: none"> <li>▪ 1/2", 1", 2"</li> </ul>                 Maximum mass flow: 50 t/h (1800 lb/min)</p>
<p>Rotamass Hygienic</p>		<p><b>For food, beverage and pharmaceutical applications</b>                  Meter sizes: Hygienic 25, Hygienic 40, Hygienic 50, Hygienic 80                  Connection sizes:  <ul style="list-style-type: none"> <li>▪ DN25, DN40, DN50, DN65, DN80</li> <li>▪ 1", 1 1/2", 2", 2 1/2", 3"</li> </ul>                 Maximum mass flow: 76 t/h (2800 lb/min)</p>
<p>Rotamass Giga</p>		<p><b>For high flow rate applications</b>                  Meter sizes: Giga 1F, Giga 2H                  Connection sizes:  <ul style="list-style-type: none"> <li>▪ DN100, DN125, DN150, DN200</li> <li>▪ 4", 5", 6", 8"</li> </ul>                 Maximum mass flow: 600 t/h (22000 lb/min)</p>

## 2 Measuring principle and flow meter design

### 2.1 Measuring principle

The measuring principle is based on the generation of Coriolis forces. For this purpose, a driver system (E) excites the two measuring tubes (M1, M2) in their first resonance frequency. Both pipes vibrate inversely phased, similar to a resonating tuning fork.

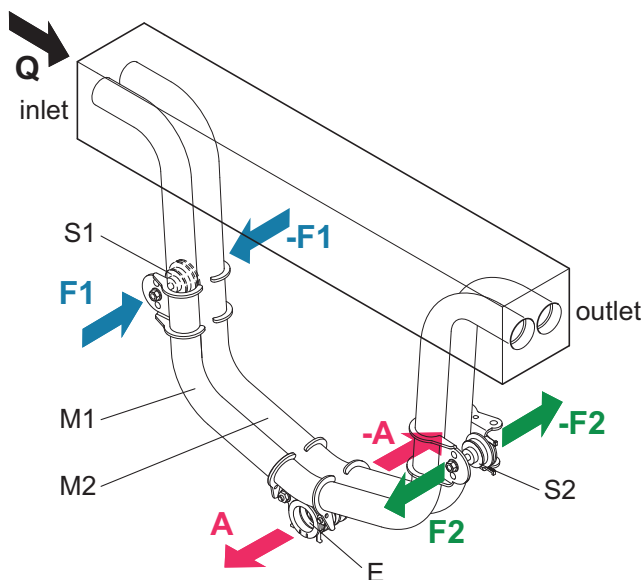

Fig. 1: Coriolis principle

M1, M2	Measuring tubes	E	Driver system
S1, S2	Pick-offs	A	Direction of measuring tube vibration
F1, F2	Coriolis forces	Q	Direction of medium flow

#### Mass flow

The medium flow through the vibrating measuring tubes generates Coriolis forces (F1, -F1 and F2, -F2) that produce positive or negative values for the tubes on the inflow or outflow side. These forces are directly proportional to the mass flow and result in deformation (torsion) of the measuring tubes.

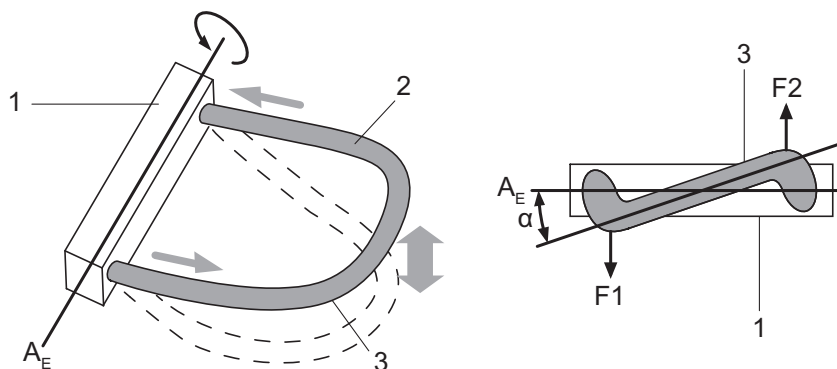

Fig. 2: Coriolis forces and measuring tube deformation

1	Measuring tube mount	$A_E$	Rotational axis
2	Medium	F1, F2	Coriolis forces
3	Measuring tube	$\alpha$	Torsion angle

The small deformation overlying the fundamental vibration is recorded by means of pick-offs (S1, S2) attached at suitable measuring tube locations. The resulting phase shift  $\Delta\phi$  between the output signals of pick-offs S1 and S2 is proportional to the mass flow. The output signals generated are further processed in a transmitter.

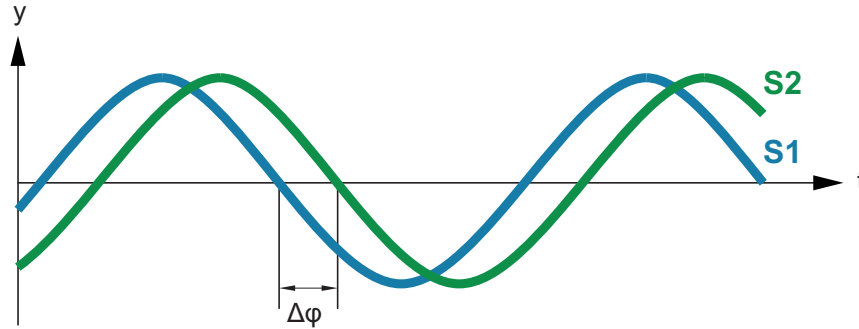

Fig. 3: Phase shift between output signals of S1 and S2 pick-offs

$$\Delta\phi \sim F_c \sim \frac{dm}{dt}$$

- $\Delta\phi$  Phase shift
- $m$  Dynamic mass
- $t$  Time
- $dm/dt$  Mass flow
- $F_c$  Coriolis force

**Density measurement**

Using a driver and an electronic regulator, the measuring tubes are operated in their resonance frequency  $f$ . This resonance frequency is a function of measuring tube geometry, material properties and the mass of the medium covibrating in the measuring tubes. Altering the density and the attendant mass will alter the resonance frequency. The transmitter measures the resonance frequency and calculates density from it according to the formula below. Device-dependent constants are determined individually during calibration.

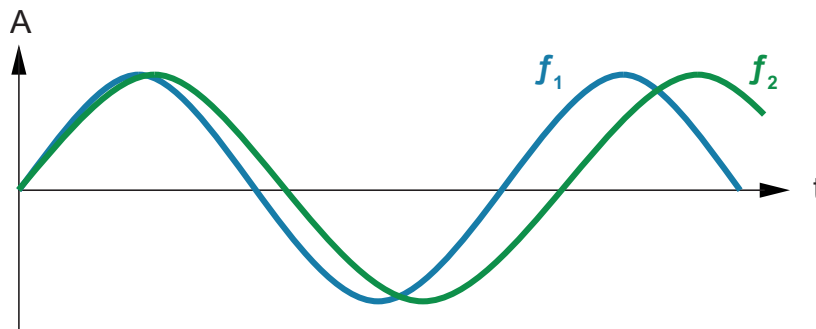

Fig. 4: Resonance frequency of measuring tubes

- A Measuring tube displacement
- $f_1$  Resonance frequency with medium 1
- $f_2$  Resonance frequency with medium 2

$$\rho = \frac{\alpha}{f^2} + \beta$$

- $\rho$  Medium density
- $f$  Resonance frequency of measuring tubes
- $\alpha, \beta$  Device-dependent constants



**Temperature measurement**

The measuring tube temperature is measured in order to compensate for the effects of temperature on the flow meter. This temperature approximately equals the medium temperature and is made available as a measured quantity at the transmitter as well.

**2.2 Flow meter**

The Rotamass Coriolis flow meter consists of:

- Sensor
- Transmitter

In the integral type, sensor and transmitter are firmly connected.

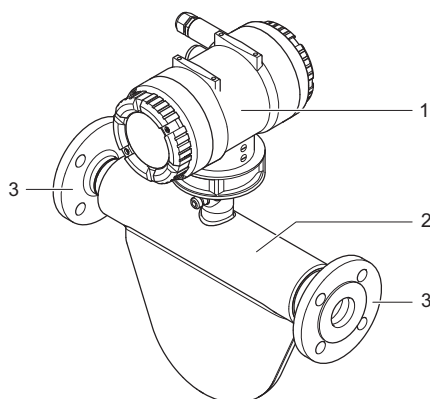

Fig. 5: Configuration of the Rotamass integral type

- |   |                     |
|---|---------------------|
| 1 | Transmitter         |
| 2 | Sensor              |
| 3 | Process connections |

When the remote type is used, sensors and transmitters are linked via connecting cable. As a result, sensor and transmitter can be installed in different locations.

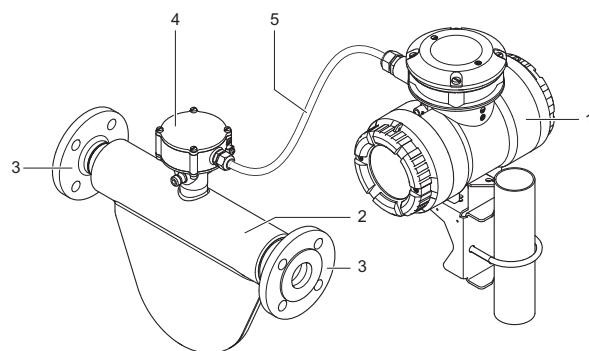

Fig. 6: Configuration of the Rotamass remote type

- |   |                     |   |                     |
|---|---------------------|---|---------------------|
| 1 | Transmitter         | 4 | Sensor terminal box |
| 2 | Sensor              | 5 | Connecting cable    |
| 3 | Process connections |   |                     |

When the remote type is used, sensors and transmitters are linked via connecting cable. As a result, sensor and transmitter can be installed in different locations.

**General specifications**

All available properties of the Rotamass Coriolis flow meter are specified by means of a model code (MS code).

One MS code position may include several characters depicted by means of dashed lines.

The positions of the MS code relevant for the respective properties are depicted and highlighted in blue. Any values that might occupy these MS code positions are subsequently explained.

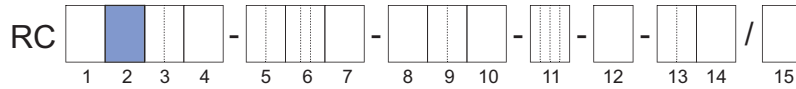

Fig. 7: Highlighted MS code positions

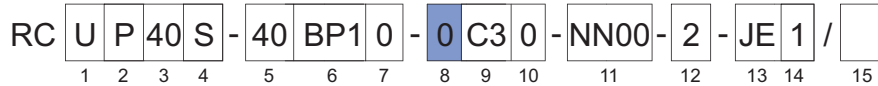
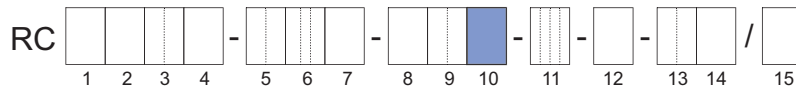

Fig. 8: Example of a completed MS code

A complete description of the MS code is included in the chapter entitled *Ordering information* [▶ 64].

**Type of design**



Position 10 of the MS code defines whether the integral type or the remote type is used. It specifies further flow meter properties, such as the transmitter coating, see *Design and housing* [▶ 85]

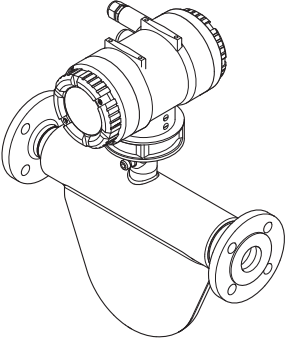
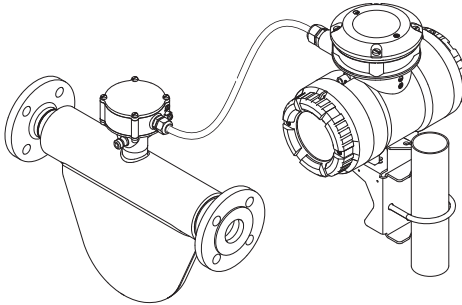

Flow meter	MS code Position 10
<p>Integral type</p> 	0, 2
<p>Remote type</p> 	A, E, J

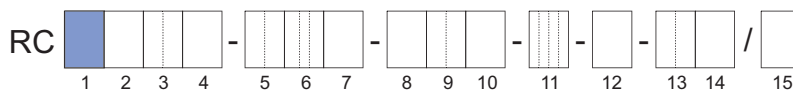
**Transmitter overview** Two different transmitters are available that differ in their functional scope.



Transmitter	Properties	MS code Position 1
<p>Essential</p> 	<ul style="list-style-type: none"> <li>▪ Down to 0.2 % mass flow accuracy for liquids</li> <li>▪ Down to 0.75 % mass flow accuracy for gases</li> <li>▪ Down to 4 g/l (0.25 lb/ft<sup>3</sup>) accuracy for density</li> <li>▪ Diagnostic functions</li> <li>▪ HART communication</li> <li>▪ Modbus communication</li> <li>▪ Data backup on microSD card</li> </ul>	E
<p>Ultimate</p> 	<ul style="list-style-type: none"> <li>▪ Down to 0.1 % mass flow accuracy for liquids</li> <li>▪ Down to 0.5 % mass flow accuracy for gases</li> <li>▪ Down to 0.5 g/l (0.03 lb/ft<sup>3</sup>) accuracy for density</li> <li>▪ Diagnostic functions</li> <li>▪ HART communication</li> <li>▪ Modbus communication</li> <li>▪ Special functions for special applications, such as dynamic pressure compensation</li> <li>▪ Data backup on microSD card</li> </ul>	U

### 3 Application and measuring ranges

#### 3.1 Measured quantities

The Rotamass Coriolis flow meter can be used to measure the following media:

- Liquids
- Gases
- Mixtures, such as emulsions, suspensions, slurries

Possible limitations applying to measurement of mixtures must be checked with the responsible Yokogawa sales organization.

The following variables can be measured using the Rotamass:

- Mass flow
- Density
- Temperature

Based on these measured quantities, the transmitter also calculates:

- Volume flow
- Partial component concentration of a two-component mixture
- Partial component flow rate of a mixture consisting of two components (net flow)

In this process, the net flow is calculated based on the known partial component concentration and the overall flow.

#### 3.2 Measuring range overview

	Prime 25	Prime 40	Prime 50	Prime 80	
<b>Mass flow range</b>					
Typical connection size	DN25, 1"	DN40, 1½"	DN50, 2"	DN80, 3"	[ 13 ]
Q <sub>nom</sub>	1.6 t/h (59 lb/min)	4.7 t/h (170 lb/min)	20 t/h (730 lb/min)	51 t/h (1900 lb/min)	
Q <sub>max</sub>	2.3 t/h (85 lb/min)	7 t/h (260 lb/min)	29 t/h (1100 lb/min)	76 t/h (2800 lb/min)	
<b>Maximum volume flow</b>					
(Water)	2.3 m <sup>3</sup> /h (19 barrel/h)	7 m <sup>3</sup> /h (59 barrel/h)	29 m <sup>3</sup> /h (240 barrel/h)	76 m <sup>3</sup> /h (640 barrel/h)	[ 13 ]
<b>Range of medium density</b>					
	0 – 5 kg/l (0 – 310 lb/ft <sup>3</sup> )				[ 13 ]
<b>Medium temperature range</b>					
Standard <sup>1)</sup>	-70 – 200 °C (-94 – 392 °F)				[ 26 ]

<sup>1)</sup> May vary depending on the design.

Q<sub>nom</sub> - Nominal mass flow

Q<sub>max</sub> - Maximum mass flow

The nominal mass flow Q<sub>nom</sub> is defined as the mass flow of water (temperature: 20 °C) at 1 bar pressure loss along the flow meter.

### 3.3 Mass flow

For Rotamass Prime the following meter sizes to be determined using the *MS code* [▶ 81] are available.

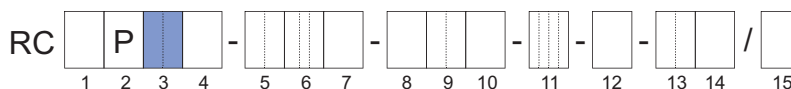

#### Mass flow of liquids

Meter size	Typical connection size	Q <sub>nom</sub> in t/h (lb/min)	Q <sub>max</sub> in t/h (lb/min)	MS code Position 3
Prime 25	DN25, 1"	1.6 (59)	2.3 (85)	25
Prime 40	DN40, 1½"	4.7 (170)	7 (260)	40
Prime 50	DN50, 2"	20 (730)	29 (1100)	50
Prime 80	DN80, 3"	51 (1900)	76 (2800)	80

#### Mass flow of gases

When using the Rotamass for measuring the flow of gases, the mass flow is usually limited by the pressure loss generated and the maximum flow velocity. Since these depend heavily on the application, please contact the local Yokogawa sales organization.

### 3.4 Volume flow

#### Volume flow of liquids (water at 20 °C)

Meter size	Volume flow (at 1 bar pressure loss) in m <sup>3</sup> /h (barrel/h)	Maximum volume flow in m <sup>3</sup> /h (barrel/h)
Prime 25	1.6 (13)	2.3 (19)
Prime 40	4.7 (39)	7 (59)
Prime 50	20 (170)	29 (240)
Prime 80	51 (430)	76 (640)

#### Volume flow of gases

When using the Rotamass for measuring the flow of gases, the flow rate is usually limited by the pressure loss generated and the maximum flow velocity. Since these depend heavily on the application, please contact the local Yokogawa sales organization.

### 3.5 Pressure loss

The pressure loss along the flow meter is heavily dependent on the application. The pressure loss of 1 bar at nominal mass flow Q<sub>nom</sub> also applies to water and is considered the reference value.

### 3.6 Density

Meter size	Measuring range of density
Prime 25	0 – 5 kg/l (0 – 310 lb/ft <sup>3</sup> )
Prime 40	
Prime 50	
Prime 80	

Rather than being measured directly, density of gas is usually calculated using its reference density, process temperature and process pressure.

### 3.7 Temperature

---

The temperature measuring range is limited by the allowed process temperature, see *Medium temperature range* [▶ 26].

Maximum measuring range: -70 – 200 °C (-94 – 392 °F)

## 4 Accuracy

In this chapter, maximum deviations are indicated as absolute values.



All accuracy data are given in  $\pm$  values.

### 4.1 Overview

#### Achievable accuracies for liquids

The value  $D_{\text{flat}}$  specified for accuracy of mass flow applies for flow rates exceeding the mass flow limit  $Q_{\text{flat}}$ . If the flow rate is less than  $Q_{\text{flat}}$ , other effects have to be considered.

The following values are achieved at calibration conditions when the device is delivered, see *Calibration conditions* [p. 23]. Depending on the product version selected, specifications may not be as accurate, see *Mass flow and density accuracy* [p. 84].

Measured quantity		Accuracy for transmitters	
		Essential	Ultimate
Mass flow <sup>1)</sup>	Accuracy <sup>2)</sup> $D_{\text{flat}}$	0.2 % of measured value	0.1 % of measured value
	Repeatability	0.1 % of measured value	0.05 % of measured value
Volume flow (water) <sup>1)</sup>	Accuracy <sup>2)</sup> $D_V$	0.45 % of measured value	0.12 % of measured value
	Repeatability	0.23 % of measured value	0.06 % of measured value
Density	Accuracy <sup>2)</sup>	4 g/l (0.25 lb/ft <sup>3</sup> )	0.5 g/l (0.03 lb/ft <sup>3</sup> )
	Repeatability	2 g/l (0.13 lb/ft <sup>3</sup> )	0.3 g/l (0.02 lb/ft <sup>3</sup> )
Temperature	Accuracy <sup>2)</sup>	1.0 °C (1.8 °F)	1.0 °C (1.8 °F)

<sup>1)</sup> Based on the measured values of the pulse output. Includes the combined effects of repeatability, linearity and hysteresis.

<sup>2)</sup> Best accuracy per transmitter type

The connecting cable may influence the accuracy. The values specified are valid for connecting cables  $\leq 30$  m (98.4 ft) long.

#### Achievable accuracies for gases

Measured quantity		Accuracy for transmitters	
		Essential	Ultimate
Mass flow / standard volume flow <sup>1)</sup>	Accuracy <sup>2)</sup> $D_{\text{flat}}$	0.75 % of measured value	0.5 % of measured value
	Repeatability	0.6 % of measured value	0.4 % of measured value
Temperature	Accuracy <sup>2)</sup>	1.0 °C (1.8 °F)	1.0 °C (1.8 °F)

<sup>1)</sup> Based on the measured values of the pulse output. Includes the combined effects of repeatability, linearity and hysteresis.

<sup>2)</sup> Best mass flow accuracy per transmitter type

In the event of medium temperature jumps, a delay is to be expected in the temperature being displayed due to low heat capacity and heat conductivity of gases.

The connecting cable may influence the accuracy. The values specified are valid for connecting cables  $\leq 30$  m (98.4 ft) long.

### 4.2 Zero point stability of the mass flow

In case of no flow, the maximum measured flow rate is called *Zero point stability*. Zero point values are shown in the table below.

Meter size	Zero point stability Z in kg/h (lb/min)
Prime 25	0.16 (0.0059)
Prime 40	0.47 (0.017)
Prime 50	2 (0.073)
Prime 80	5.1 (0.19)

### 4.3 Mass flow accuracy

Above mass flow  $Q_{flat}$ , maximum deviation is constant and referred to as  $D_{flat}$ . It depends on the product version and can be found in the tables in chapter *Accuracy of mass flow and density according to the MS code* [▶ 20].

Use the following formulas to calculate the maximum deviation  $D$ :

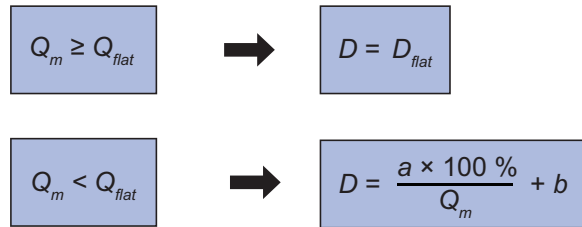

- $D$  Maximum deviation in %
- $D_{flat}$  Maximum deviation for high flow rates in %
- $a, b$  Constants
- $Q_m$  Mass flow in kg/h
- $Q_{flat}$  Mass flow value above which  $D_{flat}$  applies, in kg/h

Meter size	MS code Position 9	$D_{flat}$ in %	$Q_{flat}$ in kg/h	$a$ in kg/h	$b$ in %
Prime 25	E2, E3, E7	0.2	128	0.26	0
	D2, D3, D7	0.15	144	0.21	0.007
	C2, C3, C7	0.1	160	0.18	-0.011
	70	0.75	128	0.21	0.583
	50	0.5	160	0.18	0.389
Prime 40	E2, E3, E7	0.2	376	0.75	0
	D2, D3, D7	0.15	423	0.6	0.007
	C2, C3, C7	0.1	470	0.52	-0.011
	70	0.75	376	0.63	0.583
	50	0.5	470	0.52	0.389
Prime 50	E2, E3, E7	0.2	1600	3.2	0
	D2, D3, D7	0.15	1800	2.6	0.007
	C2, C3, C7	0.1	2000	2.2	-0.011
	70	0.75	1600	2.7	0.583
	50	0.5	2000	2.2	0.389



Meter size	MS code Position 9	$D_{flat}$ in %	$Q_{flat}$ in kg/h	$a$ in kg/h	$b$ in %
Prime 80	E2, E3, E7	0.2	4080	8.2	0
	D2, D3, D7	0.15	4590	6.6	0.007
	C2, C3, C7	0.1	5100	5.7	-0.011
	70	0.75	4080	6.8	0.583
	50	0.5	5100	5.7	0.389

### 4.3.1 Sample calculation for liquids

Accuracy using water at 20 °C as an example

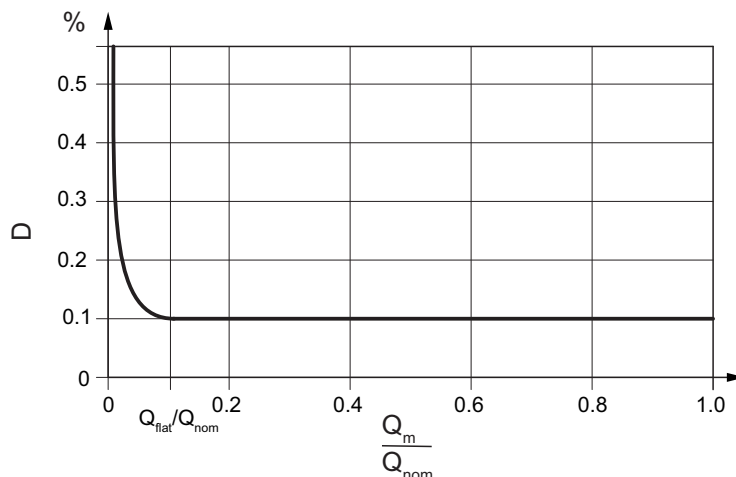

Fig. 9: Schematic dependency of the maximum deviation on the mass flow

$D$  Maximum deviation in %       $Q_m$  Mass flow in kg/h  
 $Q_{nom}$  Nominal mass flow in kg/h       $Q_{flat}$  Mass flow above which  $D_{flat}$  applies, in kg/h

Turn down $Q_m : Q_{nom}$	Maximum deviation $D$	Water pressure loss
1:100	1.1 %	≈ 0 mbar (0 psi)
1:40	0.43 %	0.7 mbar (0.01 psi)
1:10	0.1 %	10 mbar (0.15 psi)
1:2	0.1 %	250 mbar (3.62 psi)
1:1	0.1 %	1000 mbar (14.50 psi)

Example

RC U P 40 S - 40 BP1 10 - 0 C3 0 - NN00 - 2 - JE 1 /

1 2 3 4      5 6 7      8 9 10      11      12      13 14      15

Medium: Liquid  
 Maximum deviation  $D_{\text{flat}}$ : 0.1 %  
 $Q_{\text{flat}}$ : 470 kg/h  
 Constant  $a$ : 0.52 kg/h  
 Constant  $b$ : -0.011 %  
 Value of mass flow  $Q_m$ : 120 kg/h

Calculation of flow rate condition:

$$Q_m \geq Q_{\text{flat}}$$

Check whether:

$$Q = 120 \text{ kg/h} < Q_{\text{flat}} = 470 \text{ kg/h}$$

As a result, accuracy is calculated using the following formula:

$$D = \frac{a \times 100 \%}{Q_m} + b$$

Calculation of accuracy:

$$D = 0.52 \text{ kg/h} \times 100 \% / 120 \text{ kg/h} + -0.011 \%$$

$$D = 0.42 \%$$

4.3.2 Sample calculation for gases

The maximum deviation in the case of gases depends on the product version selected, see also *Mass flow and density accuracy* [ 84].

Example

RC U P 40 S - 40 BP1 0 - 0 50 0 - NN00 - 2 - JE 1 /

1 2 3 4      5 6 7      8 9 10      11      12      13 14      15

Medium: Gas  
 Maximum deviation  $D_{\text{flat}}$ : 0.5 %  
 $Q_{\text{flat}}$ : 470 kg/h  
 Constant  $a$ : 0.52 kg/h  
 Constant  $b$ : 0.389 %  
 Value of mass flow  $Q_m$ : 47 kg/h

Calculation of the flow rate condition:

$$Q_m \geq Q_{\text{flat}}$$

Check whether:

$$Q_m = 47 \text{ kg/h} < Q_{\text{flat}} = 470 \text{ kg/h}$$

As a result, the accuracy is calculated using the following formula:

$$D = \frac{a \times 100 \%}{Q_m} + b$$

Calculation of accuracy:

$$D = 0.52 \text{ kg/h} \times 100 \% / 47 \text{ kg/h} + 0.389 \%$$

$$D = 1.50 \%$$

## 4.4 Accuracy of density

### 4.4.1 For liquids

Meter size	Transmitter	Maximum deviation of density <sup>1)</sup> in g/l (lb/ft <sup>3</sup> )
Prime 25	Essential	Down to 4 (0.25)
Prime 40		
Prime 50		
Prime 80		
Prime 25	Ultimate	Down to 0.5 (0.03)
Prime 40		
Prime 50		
Prime 80		

<sup>1)</sup> Deviations possible depending on product version (type of calibration)

The maximum deviation depends on the product version selected, see also *Accuracy of mass flow and density according to the MS code* [▶ 20].

### 4.4.2 For gases

In most applications, density at standard conditions is fed into the transmitter and used to calculate the standard volume flow based on mass flow.

If gas pressure is a known value, after entering a reference density, the transmitter is able to calculate gas density from temperature and pressure as well (while assuming an ideal gas).

Alternatively, there is an option for measuring gas density. In order to do so, it is necessary to adapt the lower density limit value in the transmitter.

For most applications the direct measurement of the gas density will have insufficient accuracy.

## 4.5 Accuracy of mass flow and density according to the MS code

Accuracy for flow rate as well as density is selected via MS code position 9. Here a distinction is made between devices for measuring liquids and devices for measuring gases. No accuracy for density measurement is specified for gas measurement devices.

### 4.5.1 For liquids

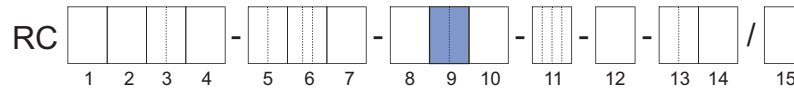

#### Essential

MS code Position 9	Maximum deviation of density <sup>1)</sup> in g/l	Applicable measuring range of accuracy in kg/l	Maximum deviation $D_{flat}$ for mass flow in %			
			Prime 25	Prime 40	Prime 50	Prime 80
E7	4	0.3 – 3.6	0.2	0.2	0.2	0.2

<sup>1)</sup> Specified maximum deviation is achieved within the applicable measuring range for density.

#### Ultimate

MS code Position 9	Maximum deviation of density <sup>1)</sup> in g/l	Applicable measuring range of accuracy in kg/l	Maximum deviation $D_{flat}$ for mass flow in %			
			Prime 25	Prime 40	Prime 50	Prime 80
E3	1	0.3 – 2.4	0.2	0.2	0.2	0.2
E2	0.5	0.3 – 2.4	0.2	0.2	0.2	0.2
D7	4	0.3 – 2.4	0.15	0.15	0.15	0.15
D3	1	0.3 – 2.4	0.15	0.15	0.15	0.15
D2	0.5	0.3 – 2.4	0.15	0.15	0.15	0.15
C7	4	0.3 – 2.4	0.1	0.1	0.1	0.1
C3	1	0.3 – 2.4	0.1	0.1	0.1	0.1
C2	0.5	0.3 – 2.4	0.1	0.1	0.1	0.1

<sup>1)</sup> Specified maximum deviation is achieved within the applicable measuring range for density.

### 4.5.2 For gases

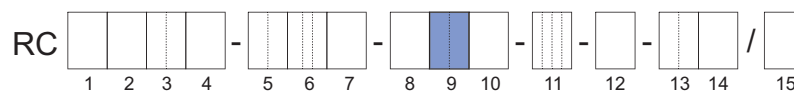

#### Essential

Maximum deviation $D_{flat}$ of mass flow in %	MS code Position 9
0.75	70

#### Ultimate

Maximum deviation $D_{flat}$ of mass flow in %	MS code Position 9
0.5	50

## 4.6 Volume flow accuracy

### 4.6.1 For liquids

The following formula can be used to calculate the accuracy of liquid volume flow:

$$D_v = \sqrt{D^2 + \left(\frac{\Delta\rho}{\rho} \times 100\%\right)^2}$$

$D_v$	Maximum deviation of volume flow in %	$D$	Maximum deviation of mass flow in %
$\Delta\rho$	Maximum deviation of density in kg/l	$\rho$	Density in kg/l

### 4.6.2 For gases

Accuracy of standard volume flow for gas with a fixed composition equals the maximum deviation  $D$  of the mass flow.

$$D_v = D$$



In order to determine the standard volume flow for gas, it is necessary to input a reference density in the transmitter. The accuracy specified is achieved only for fixed gas composites. Major deviations may appear if the gas composition changes.

### 4.7 Accuracy of temperature

Various medium temperature ranges are specified for Rotamass Prime:

- Integral type: -50 – 150 °C (-58 – 302 °F)
- Remote type: -70 – 200 °C (-94 – 392 °F)

For possible limitations on use in hazardous areas, see Ex instruction manual (IM 01U10X\_-00EN).

Accuracy of temperature depends on the sensor temperature range selected (see *Medium temperature range* [▶ 26]) and can be calculated as follows:

Formula for temperature specification Standard

$$\Delta T = 1.0 \text{ °C} + 0.0075 \times |T_{pro} - 20 \text{ °C}|$$

$\Delta T$  Maximum deviation of temperature  
 $T_{pro}$  Temperature of medium in °C

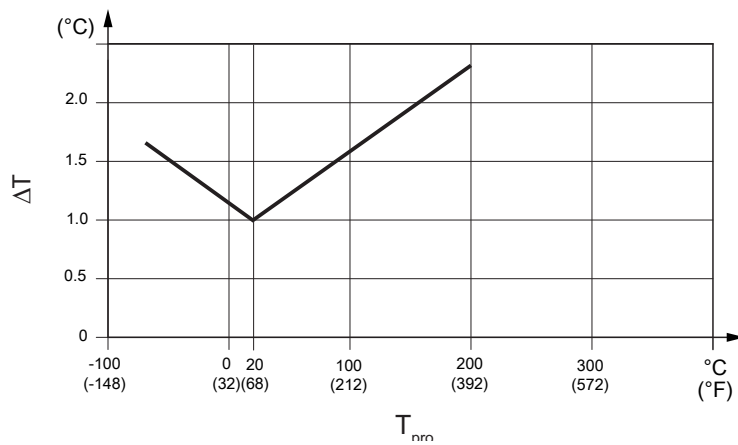

Fig. 10: Temperature accuracy

Example

RC U P 40 S - 40 BP1 0 - 0 C3 0 - NN00 - 2 - JE 1 /  

1 2 3 4 5 6 7 8 9 10 11 12 13 14 15

The sample MS code specifies the Standard temperature range.

Temperature of medium  $T_{pro}$ : 50 °C

**Calculation of accuracy:**

$$\Delta T = 1 \text{ °C} + 0.0075 \times |50 \text{ °C} - 20 \text{ °C}|$$

$$\Delta T = 1.225 \text{ °C}$$

### 4.8 Repeatability

For liquids

When using default damping times, the specified repeatability of mass flow, density and temperature measurements equals half of the respective maximum deviation.

$$R = \frac{D}{2}$$

$R$  Repeatability  
 $D$  Maximum deviation

For gases

In deviation hereto, the following applies to mass and standard volume flow of gases:

$$R = \frac{D}{1.25}$$

## 4.9 Calibration conditions

### 4.9.1 Mass flow calibration and density adjustment

All Rotamass are calibrated in accordance with the state of the art at Rota Yokogawa. Optionally, the calibration can be performed according to a method accredited by DAkkS in accordance with DIN EN ISO/IEC 17025 (Option K5, see *Certificates* [▶ 93]).

Each Rotamass device comes with a standard calibration certificate.

Calibration takes place at reference conditions. Specific values are listed in the standard calibration certificate.

	Reference conditions
Medium	Water
Density	0.9 – 1.1 kg/l (56 – 69 lb/ft <sup>3</sup> )
Medium temperature	10 – 35 °C (50 – 95 °F) Average temperature: 22.5 °C (72.5 °F)
Ambient temperature	10 – 35 °C (50 – 95 °F)
Process pressure (absolute)	1 – 2 bar (15 – 29 psi)

The accuracy specified is achieved at as-delivered calibration conditions stated.

### 4.9.2 Density calibration

Density calibration is performed for maximum deviation of 0.5 g/l (MS code position 9 \_2).

Density calibration includes:

- Determination of calibration constants for medium densities at 0.7 kg/l (44 lb/ft<sup>3</sup>), 1 kg/l (62 lb/ft<sup>3</sup>) and 1.65 kg/l (103 lb/ft<sup>3</sup>) at 20 °C (68 °F) medium temperature
- Determination of temperature compensation coefficients at 20 – 80 °C (68 – 176 °F)
- Check of results for medium densities at 0.7 kg/l (44 lb/ft<sup>3</sup>), 1 kg/l (62 lb/ft<sup>3</sup>) and 1.65 kg/l (103 lb/ft<sup>3</sup>) at 20 °C (68 °F) medium temperature
- Creation of density calibration certificate

## 4.10 Process pressure effect

Process pressure effect is defined as the change in sensor flow and density deviation due to process pressure change away from the calibration pressure. This effect can be corrected by dynamic pressure input or a fixed process pressure.

Tab. 1: Process pressure effect for all Rotamass models

Meter size	Deviation of Flow		Deviation of Density	
	% of rate per bar	% of rate per psi	g/l per bar	g/l per psi
Prime 25	-0.0020	-0.00014	-0.021	-0.0014
Prime 40	-0.0084	-0.00058	-0.151	-0.0104
Prime 50	-0.0109	-0.00075	-0.073	-0.0050
Prime 80	-0.0130	-0.00090	-0.091	-0.0063

### 4.11 Process temperature effect

For mass flow and density measurement, process temperature effect is defined as the change in sensor flow and density accuracy due to process temperature change away from the calibration temperature. For temperature ranges, see *Medium temperature range* [▶ 26].

**Temperature effect on Zero**

Temperature effect on Zero of mass flow can be corrected by zeroing at the process temperature.

**Temperature effect on mass flow**

The process temperature is measured and the temperature effect compensated. However due to uncertainties in the compensation coefficients and in the temperature measurement an uncertainty of this compensation is left. The typical rest error of Rotamass TI temperature effect on mass flow is:

Tab. 2: All models

Temperature range	Uncertainty of flow
Standard	±0.0009 % of rate / °C (±0.0005 % of rate / °F)

The temperature used for calculation of the uncertainty is the difference between process temperature and the temperature at calibration condition. For temperature ranges, see *Medium temperature range* [▶ 26].

**Temperature effect on density measurement (liquids)**

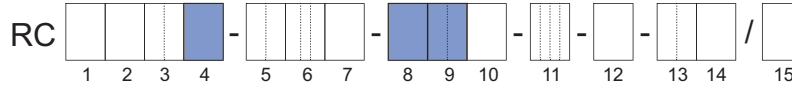

Process temperature influence:

**Formula for metric values**

$$D'_\rho = \pm k \times \text{abs}(T_{\text{pro}} - 20 \text{ }^\circ\text{C})$$

**Formula for imperial values**

$$D'_\rho = \pm k \times \text{abs}(T_{\text{pro}} - 68 \text{ }^\circ\text{F})$$

- $D'_\rho$  Additional density deviation due to the effect of medium temperature in kg/l (lb/ft<sup>3</sup>)
- $T_{\text{pro}}$  Temperature of medium in °C (°F)
- $k$  Constant for temperature effect on density measurement in g/l × 1/°C (lb/ft<sup>3</sup> × 1/°F)

Tab. 3: Constants for particular meter size and MS code Position (see also *Medium temperature range* [▶ 26] and *Mass flow and density accuracy* [▶ 84])

Meter size	MS code Position 4	MS code Position 8	MS code Position 9	$k$ in g/l × 1/°C (lb/ft <sup>3</sup> × 1/°F)
Prime 25	S	0	C3, C7, D3, D7, E3, E7	0.200 (0.0069)
			C2, D2, E2	0.030 (0.0010)
Prime 40			C3, C7, D3, D7, E3, E7	0.130 (0.0045)
			C2, D2, E2	0.020 (0.0007)
Prime 50			C3, C7, D3, D7, E3, E7	0.120 (0.0042)
			C2, D2, E2	0.018 (0.0006)
Prime 80	C3, C7, D3, D7, E3, E7	0.120 (0.0042)		
	C2, D2, E2	0.018 (0.0006)		



## 5 Operating conditions

### 5.1 Location and position of installation

Rotamass Coriolis flow meters can be mounted horizontally, vertically and at an incline. The measuring tubes should be completely filled with the medium during flow measurement as accumulations of air or formation of gas bubbles in the measuring tube may result in errors in measurement. Straight pipe runs at inlet or outlet are usually not required.

Avoid the following installation locations and positions:

- Measuring tubes as highest point in piping when measuring liquids
- Measuring tubes as lowest point in piping when measuring gases
- Immediately in front of a free pipe outlet in a downpipe
- Lateral positions

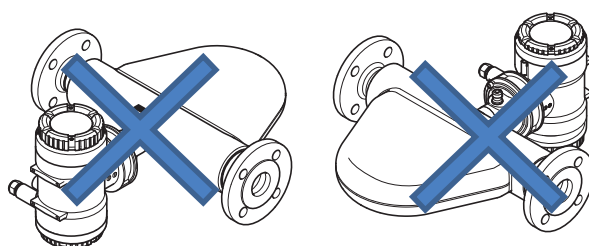
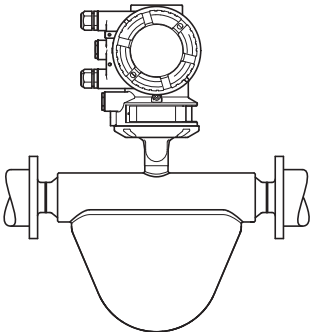
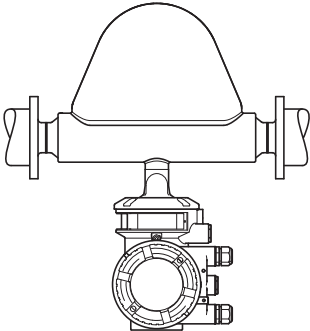
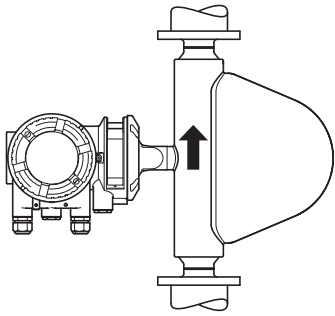

Fig. 11: Installation position to be avoided: Flow meter in sideways position

#### 5.1.1 Sensor installation position

Sensor installation position as a function of the medium

Installation position	Medium	Description
Horizontal, measuring tubes at bottom 	Liquid	The measuring tubes are oriented toward the bottom. Accumulation of gas bubbles is avoided.
Horizontal, measuring tubes at top 	Gas	The measuring tubes are oriented toward the top. Accumulation of liquid, such as condensate is avoided.

Installation position	Medium	Description
Vertical, direction of flow towards the top 	Liquid/gas	The sensor is installed on a pipe with the direction of flow towards the top. Accumulation of gas bubbles or solids is avoided. This position allows for complete self-draining of the measuring tubes.

### 5.2 Installation instructions

The following instructions for installation must be observed:

1. Protect the flow meter from direct sun irradiation in order to avoid exceeding the maximum allowed internal temperature of the transmitter.
2. In case of installing two sensors of the same kind back-to-back redundantly, use a customized design and contact the responsible Yokogawa sales organization.
3. Avoid installation locations susceptible to cavitation, such as immediately behind a control valve.
4. Avoid installation directly behind rotary and gear pumps to prevent fluctuations in pressure from interfering with the resonance frequency of the Rotamass measuring tubes.
5. In case of remote installation: When installing the connection cable between sensor and transmitter, keep the cable temperature above -10 °C (14 °F) to prevent cable damage from the installation stresses.

### 5.3 Process conditions



The pressure and temperature ratings presented in this section represent the design values for the devices. For individual applications (e.g. marine applications with option MC\_) further limitations may apply according to the respective applicable regulations. For details see chapter *Marine Approval* [▶ 96]

#### 5.3.1 Medium temperature range



The Rotamass specification for use in Ex areas is different, see Ex instruction manual (IM 01U10X\_-00EN).

For Rotamass Prime the following medium temperature ranges are available:

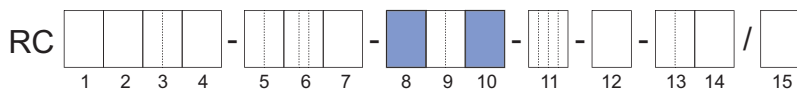

Temperature range	MS code Position 8	Medium temperature in °C (°F)	Design	MS code Position 10
Standard	0	-50 – 150 (-58 – 302)	Integral type	0, 2
		-70 – 200 (-94 – 392)	Remote type	A, E, J

5.3.2 Density

Meter size	Measuring range of density
Prime 25	0 – 5 kg/l (0 – 310 lb/ft³)
Prime 40	
Prime 50	
Prime 80	

Rather than being measured directly, density of gas is usually calculated using its reference density, process temperature and process pressure.

5.3.3 Pressure

The maximum allowed process pressure depends on the process connection temperature and the process connections selected.

The following diagrams show the process pressure as a function of process connection temperature as well as the process connection used (type and size of process connection).

ASME class 150  
JPI class 150

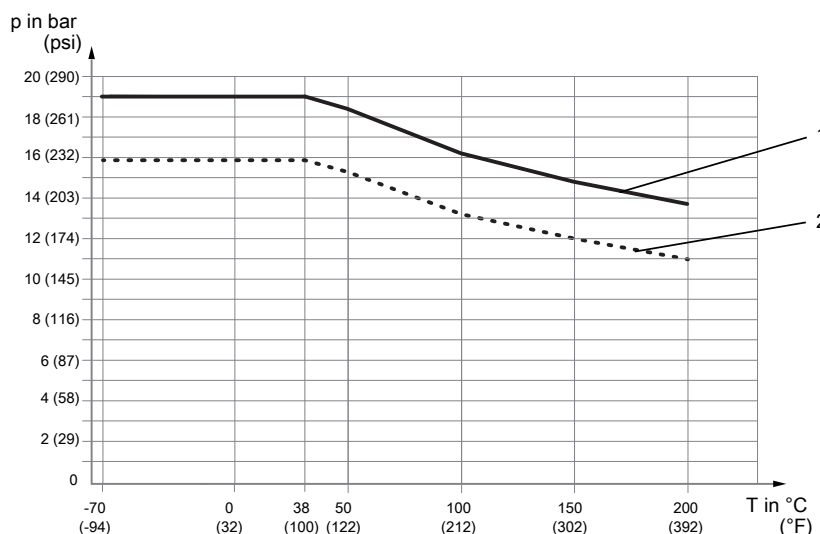

Fig. 12: Allowed process pressure as a function of process connection temperature

- 1 Process connection suitable for ASME B16.5 class 150
- 2 Process connection suitable for JPI class 150

**ASME class 300**  
**EN PN40**  
**JPI class 300**

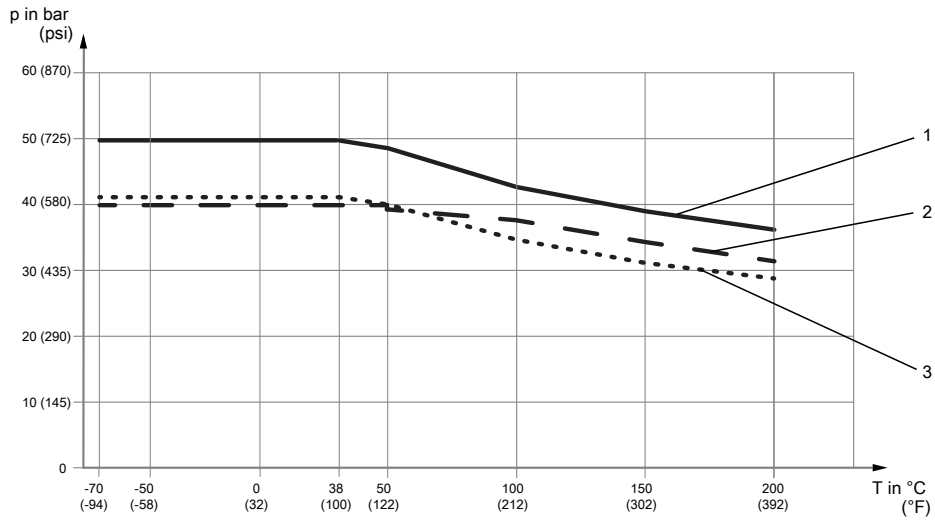

Fig. 13: Allowed process pressure as a function of process connection temperature

- 1 Process connection suitable for ASME B16.5 class 300
- 2 Process connection suitable for EN 1092-1 PN40
- 3 Process connection suitable for JPI class 300

**ASME class 600**  
**EN PN63**  
**JPI class 600**

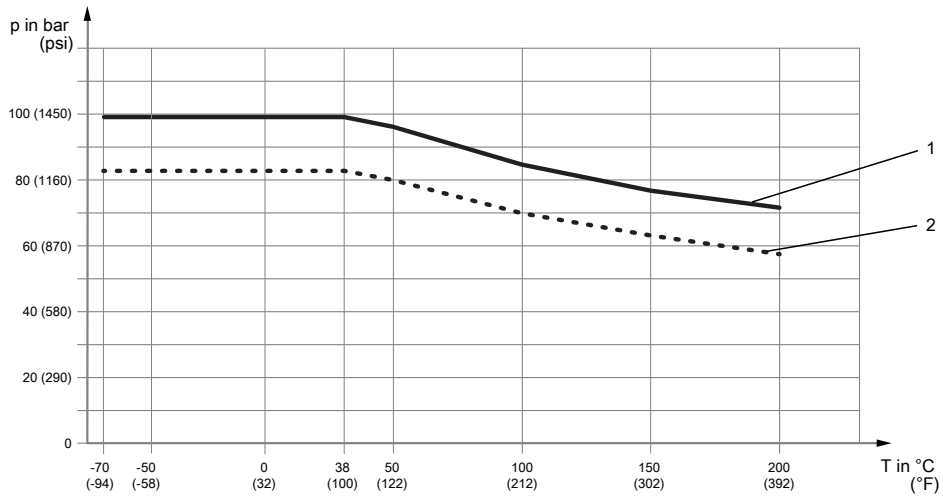

Fig. 14: Allowed process pressure as a function of process connection temperature

- 1 Flange suitable for ASME B16.5 class 600
- 2 Flange suitable for JPI class 600

**EN PN100**

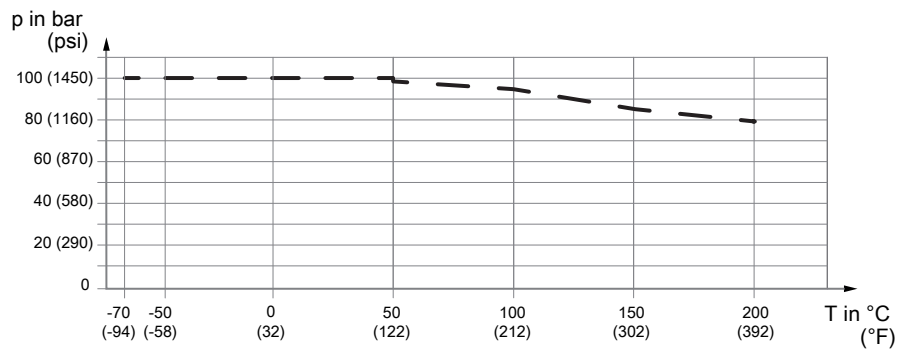

Fig. 15: Allowed process pressure as a function of process connection temperature, suitable for flange EN 1092-1 PN100

JIS 10K  
JIS 20K

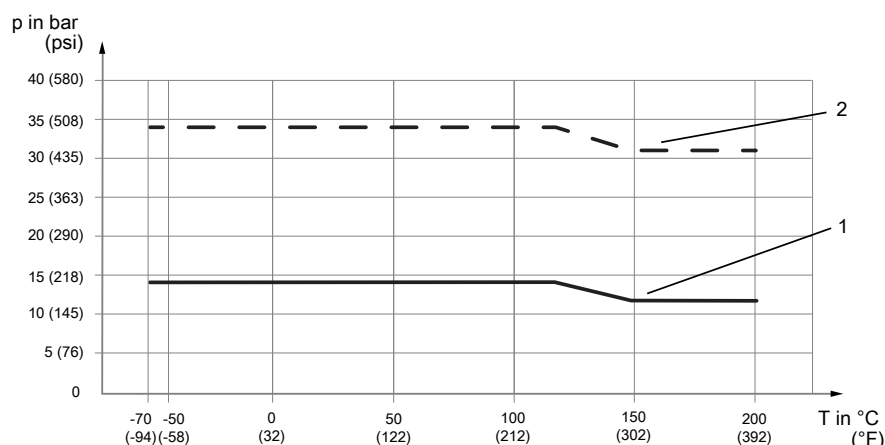

Fig. 16: Allowed process pressure as a function of process connection temperature

- 1 Flange suitable for JIS B 2220 10K
- 2 Flange suitable for JIS B 2220 20K

Process connections with internal thread

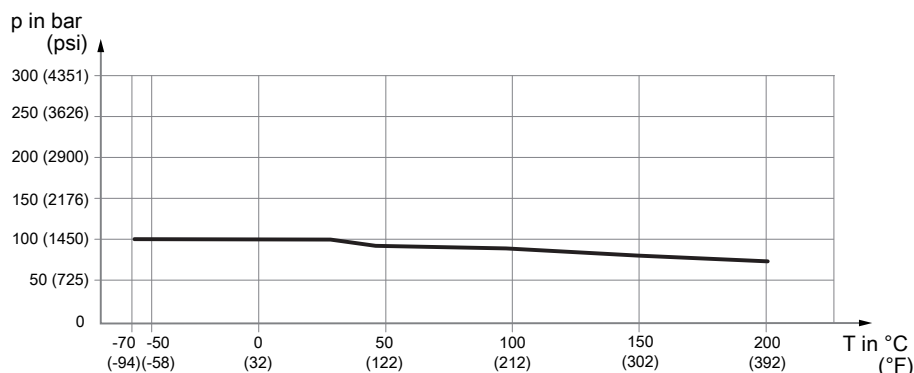
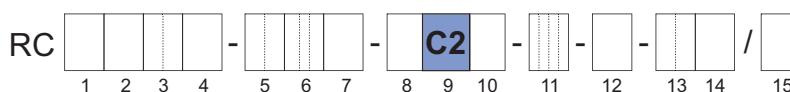

Fig. 17: Allowed process pressure as a function of temperature, suitable for process connection temperature, suitable for process connections with internal thread G and NPT

### 5.3.4 Effect of temperature on accuracy

Effect of medium temperature

The specified accuracy of the density measurement (see *Mass flow and density accuracy* [▶ 84]) applies at calibration conditions and may deteriorate if medium temperatures deviate from those conditions. The effect of temperature is minimal for the product version with MS code position 9, value `_2`.



The effect of temperature is calculated as follows:

Formula for metric values

$$D'_\rho = \pm k \times \text{abs}(T_{\text{pro}} - 20 \text{ }^\circ\text{C})$$

Formula for imperial values

$$D'_\rho = \pm k \times \text{abs}(T_{\text{pro}} - 68 \text{ }^\circ\text{F})$$

- $D'_\rho$  Additional density deviation due to the effect of medium temperature in kg/l (lb/ft<sup>3</sup>)
- $T_{\text{pro}}$  Temperature of medium in °C (°F)
- $k$  Constant for temperature effect on density measurement in g/l × 1/°C (lb/ft<sup>3</sup> × 1/°F)

**5.3.5 Secondary containment**

Some applications or environment conditions require secondary containment retaining the process pressure for increased safety. All Rotamass TI have a secondary containment filled with inert gas. The rupture pressure typical values of the secondary housing are defined in the below table.

Typical Rupture pressure

Prime 25	Prime 40	Prime 50	Prime 80
Rupture pressure in bar (psi)	Rupture pressure in bar (psi)	Rupture pressure in bar (psi)	Rupture pressure in bar (psi)
59 (855)	59 (855)	59 (855)	59 (855)

**5.4 Ambient conditions**

Rotamass can be used at demanding ambient conditions.

In doing so, the following specifications must be taken into account:

Ambient temperature	<ul style="list-style-type: none"> <li>▪ Sensor: see [▶ 31]</li> <li>▪ Transmitter: -40 – 60 °C (-40 – 140 °F)</li> <li>▪ Cable:                             <ul style="list-style-type: none"> <li>standard (option L_...): -50 °C – 80 °C (-58 °F – 176 °F)</li> <li>fire retardant (option Y_...): -35°C – 80°C (-31 – 176°F)</li> </ul> </li> <li>▪ Transmitter display has limited legibility below -20 °C (-4 °F)</li> </ul>
Storage temperature	<ul style="list-style-type: none"> <li>▪ Sensor: -50 – 80 °C (-58 – 176 °F)</li> <li>▪ Transmitter: -40 – 60 °C (-40 – 140 °F)</li> <li>▪ Cable:                             <ul style="list-style-type: none"> <li>standard (option L_...): -50 °C – 80 °C (-58 °F – 176 °F)</li> <li>fire retardant (option Y_...): -35°C – 80°C (-31 – 176°F)</li> </ul> </li> </ul>
Relative humidity	0 – 95 %
IP code	IP66/67 for transmitters and sensors when using the appropriate cable glands
Allowable pollution degree in surrounding area according to EN 61010-1	4 (in operation)
Vibration resistance according to IEC 60068-2-6	Transmitter: 10 – 500 Hz, 1g Sensor: 10 – 500 Hz, 1g
Electromagnetic compatibility (EMC) according to IEC/EN 61326-1, Class A, Table 2, IEC/EN 61326-2-3, IEC/EN 61000-3-2, IEC/EN 61000-3-3 as well as NAMUR recommendation NE 21 and environmental tests according to DNVGL-CG-0339	Requirement during immunity tests: The output signal fluctuation is specified within ±1 % of the output span.
Maximum altitude	2000 m (6600 ft) above mean sea level (MSL)
Overvoltage category according to IEC/EN 61010-1	II

### 5.4.1 Allowed ambient temperature for sensor

The allowed ambient temperature depends on the following product properties:

- Temperature specification, see *Medium temperature range* [▶ 26]
- Housing design
  - Integral type
  - Remote type
- Medium temperature
- Connecting cable type (Options L<sub>---</sub> and Y<sub>---</sub>)

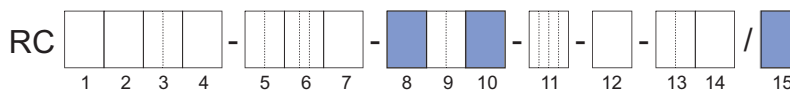

The allowed combinations of medium and ambient temperature for the sensor are illustrated as gray areas in the diagrams below.



The Rotamass specification for use in Ex areas is different, see Ex instruction manual (IM 01U10X<sub>---</sub>-00EN).



The minimum allowed ambient temperature for remote fire retardant connecting cable type Y<sub>---</sub> is -35 °C. In case of process temperatures below -35 °C, the minimum allowed ambient temperature has to be reconsidered.

Temperature specification  
Standard, integral type

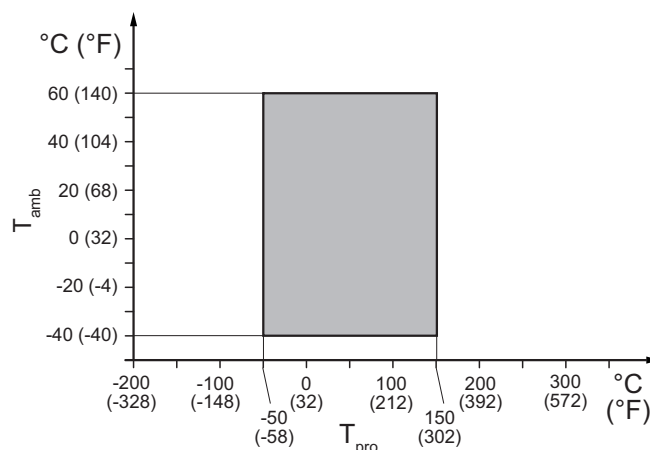

Fig. 18: Allowed medium and ambient temperatures, integral type

T<sub>amb</sub> Ambient temperature

T<sub>pro</sub> Medium temperature

Temperature specification  
Standard, remote type

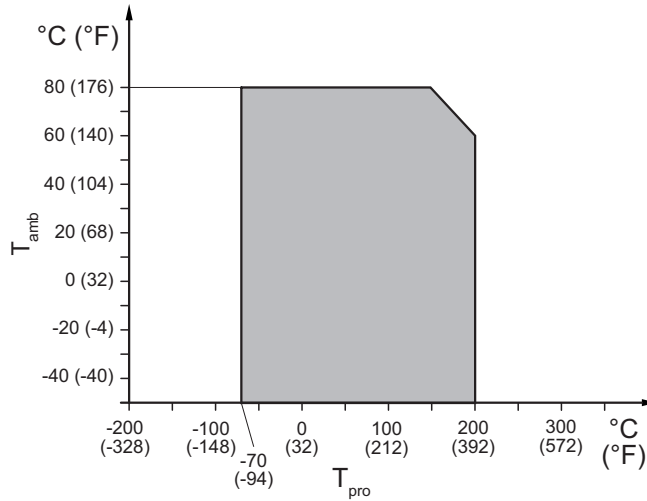

Fig. 19: Allowed medium and ambient temperatures, remote type

5.4.2 Temperature specification in hazardous areas

The Maximum ambient and process temperature depending on explosion groups and temperature classes are related to different characteristics:

- Size of the sensor (MS code Pos.3)
- Design and housing (MS code Pos.10)
- Type of EX Approval (MS code Pos.11)
- Expanded Process Temperature (MS code Pos.15: Option “EPT”)

MS code:

Pos. 2: P

Pos. 3: 25, 40

Pos. 10: 0, 2

Pos. 11: \_F21, \_F22, FF11, FF12

Pos. 15: –

Ex code:

7.66.66.68.54.10

The following figure shows the relevant positions of the MS code:

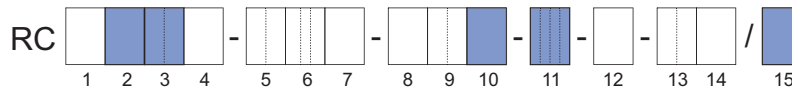

Tab. 4: Temperature classification

Temperature class	Maximum ambient temperature in °C (°F)	Maximum medium temperature in °C (°F)
T6	43 (109)	47 (116)
T5	58 (136)	62 (143)
T4	60 (140)	99 (210)
T3	60 (140)	150 (302)
T2	60 (140)	150 (302)
T1	60 (140)	150 (302)



MS code:

Pos. 2: P

Pos. 3: 25, 40

Pos. 10: 0, 2

Pos. 11: \_F21, \_F22, FF11, FF12

Pos. 15: EPT

Ex code:

1.83.83.84.54.10

The following figure shows the relevant positions of the MS code:

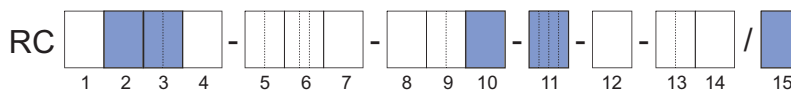

Tab. 5: Temperature classification

Temperature class	Maximum ambient temperature in °C (°F)	Maximum medium temperature in °C (°F)
T6	60 (140)	64 (147)
T5	60 (140)	79 (174)
T4	60 (140)	115 (239)
T3	60 (140)	150 (302)
T2	60 (140)	150 (302)
T1	60 (140)	150 (302)

MS code:

Pos. 2: P

Pos. 3: 50

Pos. 10: 0, 2

Pos. 11: \_F21, \_F22, FF11, FF12

Pos. 15: -

Ex code:

2.73.72.76.54.10

The following figure shows the relevant positions of the MS code:

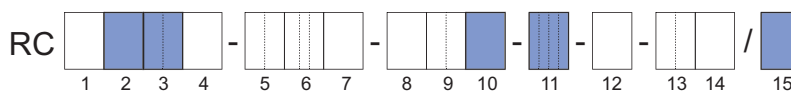

Tab. 6: Temperature classification

Temperature class	Maximum ambient temperature in °C (°F)	Maximum medium temperature in °C (°F)
T6	54 (129)	54 (129)
T5	60 (140)	68 (154)
T4	60 (140)	107 (224)
T3	60 (140)	150 (302)
T2	60 (140)	150 (302)
T1	60 (140)	150 (302)

MS code:

Pos. 2: P

Pos. 3: 50

Pos. 10: 0, 2

Pos. 11: \_F21, \_F22, FF11, FF12

Pos. 15: EPT

Ex code:

1.91.91.91.54.10

The following figure shows the relevant positions of the MS code:

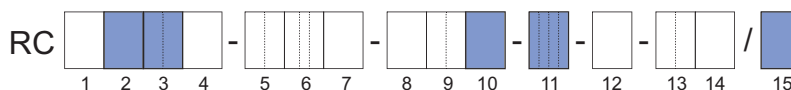

Tab. 7: Temperature classification

Temperature class	Maximum ambient temperature in °C (°F)	Maximum medium temperature in °C (°F)
T6	60 (140)	72 (161)
T5	60 (140)	87 (188)
T4	60 (140)	122 (251)
T3	60 (140)	150 (302)
T2	60 (140)	150 (302)
T1	60 (140)	150 (302)

MS code:

Pos. 2: P

Pos. 3: 80

Pos. 10: 0, 2

Pos. 11: \_F21, FF11

Pos. 15: –

Ex code:

7.83.84.86.54.10

The following figure shows the relevant positions of the MS code:

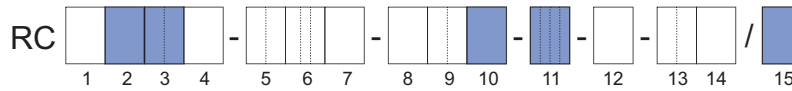

Tab. 8: Temperature classification

Temperature class	Maximum ambient temperature in °C (°F)	Maximum medium temperature in °C (°F)
T6	40 (104)	64 (147)
T5	55 (131)	80 (176)
T4	60 (140)	117 (242)
T3	60 (140)	150 (302)
T2	60 (140)	150 (302)
T1	60 (140)	150 (302)

MS code:

Pos. 2: P

Pos. 3: 80

Pos. 10: 0, 2

Pos. 11: \_F22, FF12

Pos. 15: –

Ex code:

6.83.84.86.54.10

The following figure shows the relevant positions of the MS code:

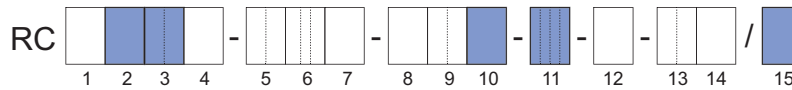

Tab. 9: Temperature classification

Temperature class	Maximum ambient temperature in °C (°F)	Maximum medium temperature in °C (°F)
T6	44 (111)	64 (147)
T5	59 (138)	80 (176)
T4	60 (140)	117 (242)
T3	60 (140)	150 (302)
T2	60 (140)	150 (302)
T1	60 (140)	150 (302)

MS code:

Pos. 2: P

Pos. 3: 25, 40

Pos. 10: A, E, J

Pos. 11: \_F21, \_F22, FF11, FF12

Pos. 15: –

Ex code:

7.66.66.68.66.60

The following figure shows the relevant positions of the MS code:

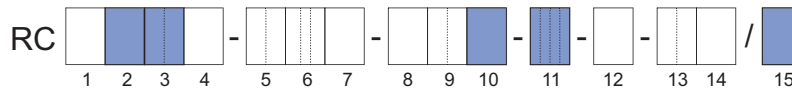

Tab. 10: Temperature classification

Temperature class	Maximum ambient temperature in °C (°F)		Maximum medium temperature in °C (°F)
	Option L_ _ _ _	Option Y_ _ _ _ <sup>1)</sup>	
T6	46 (114)	46 (114)	47 (116)
T5	61 (141)	61 (141)	62 (143)
T4	80 (176)	74 (165)	99 (210)
T3	74 (165)	56 (132)	162 (323)
T2	60 (140)	46 (114)	200 (392)
T1	60 (140)	46 (114)	200 (392)

<sup>1)</sup> only with SF2\_ and KF2\_

MS code:

Pos. 2: P

Pos. 3: 25, 40

Pos. 10: A, E, J

Pos. 11: \_F21, \_F22, FF11, FF12

Pos. 15: EPT

Ex code:

1.83.83.84.82.60

The following figure shows the relevant positions of the MS code:

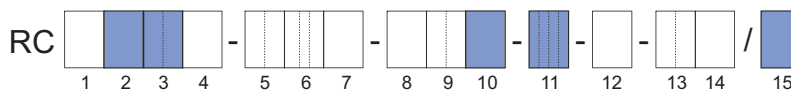

Tab. 11: Temperature classification

Temperature class	Maximum ambient temperature in °C (°F)		Maximum medium temperature in °C (°F)
	Option L_ _ _ _	Option Y_ _ _ _ <sup>1)</sup>	
T6	64 (147)	64 (147)	64 (147)
T5	79 (174)	79 (174)	79 (174)
T4	80 (176)	66 (150)	115 (239)
T3	68 (154)	51 (123)	178 (352)
T2	60 (140)	46 (114)	200 (392)
T1	60 (140)	46 (114)	200 (392)

<sup>1)</sup> only with SF2\_ and KF2\_

MS code:

Pos. 2: P

Pos. 3: 50

Pos. 10: A, E, J

Pos. 11: \_F21, \_F22, FF11, FF12

Pos. 15: –

Ex code:

2.73.72.76.80.60

The following figure shows the relevant positions of the MS code:

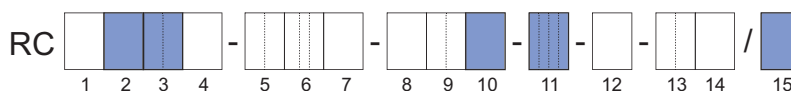

Tab. 12: Temperature classification

Temperature class	Maximum ambient temperature in °C (°F)		Maximum medium temperature in °C (°F)
	Option L_ _ _ _	Option Y_ _ _ _ <sup>1)</sup>	
T6	54 (129)	54 (129)	54 (129)
T5	68 (154)	68 (154)	68 (154)
T4	80 (176)	66 (150)	107 (224)
T3	68 (154)	51 (123)	176 (348)
T2	60 (140)	46 (114)	200 (392)
T1	60 (140)	46 (114)	200 (392)

<sup>1)</sup> only with SF2\_ and KF2\_

MS code:

Pos. 2: P

Pos. 3: 50

Pos. 10: A, E, J

Pos. 11: \_F21, \_F22, FF11, FF12

Pos. 15: EPT

Ex code:

1.91.91.91.91.60

The following figure shows the relevant positions of the MS code:

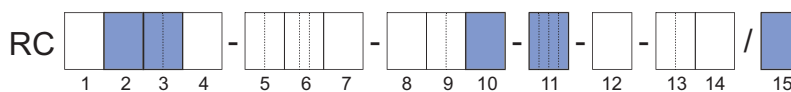

Tab. 13: Temperature classification

Temperature class	Maximum ambient temperature in °C (°F)		Maximum medium temperature in °C (°F)
	Option L_ _ _ _	Option Y_ _ _ _ <sup>1)</sup>	
T6	72 (161)	72 (161)	72 (161)
T5	80 (176)	77 (170)	87 (188)
T4	80 (176)	66 (150)	122 (251)
T3	64 (147)	49 (120)	187 (368)
T2	60 (140)	46 (114)	200 (392)
T1	60 (140)	46 (114)	200 (392)

<sup>1)</sup> only with SF2\_ and KF2\_

MS code:

Pos. 2: P

Pos. 3: 80

Pos. 10: A, E, J

Pos. 11: \_F21, FF11

Pos. 15: –

Ex code:

7.83.84.86.89.60

The following figure shows the relevant positions of the MS code:

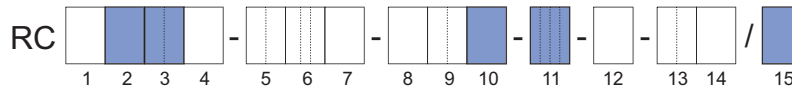

Tab. 14: Temperature classification

Temperature class	Maximum ambient temperature in °C (°F)		Maximum medium temperature in °C (°F)
	Option L_ _ _ _	Option Y_ _ _ _ <sup>1)</sup>	
T6	42 (107)	42 (107)	64 (147)
T5	57 (134)	57 (134)	80 (176)
T4	80 (176)	66 (150)	117 (242)
T3	66 (150)	50 (122)	185 (365)
T2	60 (140)	46 (114)	200 (392)
T1	60 (140)	46 (114)	200 (392)

<sup>1)</sup> only with SF2\_ and KF2\_

MS code:

Pos. 2: P

Pos. 3: 80

Pos. 10: A, E, J

Pos. 11: \_F22, FF12

Pos. 15: –

Ex code:

6.83.84.86.89.60

The following figure shows the relevant positions of the MS code:

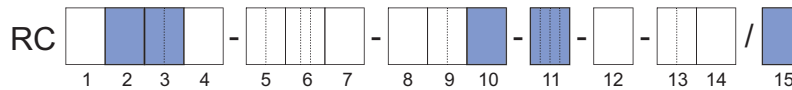

Tab. 15: Temperature classification

Temperature class	Maximum ambient temperature in °C (°F)		Maximum medium temperature in °C (°F)
	Option L_ _ _ _	Option Y_ _ _ _ <sup>1)</sup>	
T6	46 (114)	46 (114)	64 (147)
T5	61 (141)	61 (141)	80 (176)
T4	80 (176)	66 (150)	117 (242)
T3	66 (150)	50 (122)	185 (365)
T2	60 (140)	46 (114)	200 (392)
T1	60 (140)	46 (114)	200 (392)

<sup>1)</sup> only with SF2\_ and KF2\_

## 6 Mechanical specification

### 6.1 Design

The Rotamass flow meter is available with two versions:

- Integral type, sensor and transmitter are firmly connected
- Remote type, standard terminal box

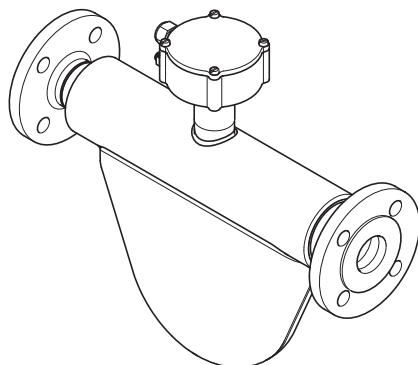
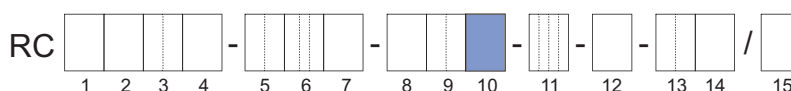

Fig. 20: Remote type sensor with standard terminal box



Design	Design	Available temperature specifications	MS code Position 10
Integral type	Direct connection	Standard	0, 2
Remote type	Standard terminal box	Standard	A, E, J



The design influences the temperature specification for Ex-approved Rotamass, see Ex instruction manual (IM 01U10X\_--00EN-R).

## 6.2 Material

### 6.2.1 Material wetted parts

For Rotamass Prime, wetted parts are available in stainless steel alloy.

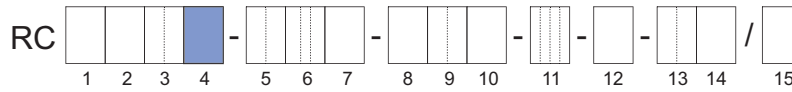

Material	MS code Position 4
Stainless steel 1.4404/316L	S

### 6.2.2 Non-wetted parts

Housing material of sensor and transmitter are specified via MS code position 7 and position 10.

Sensor housing material

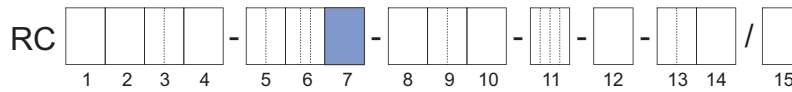

Housing material	MS code Position 7
Stainless steel 1.4301/304, 1.4404/316L	0

Transmitter housing material, coating and bracket

The transmitter housing is available with different coatings:

- Standard coating  
Urethane-cured polyester powder coating
- Corrosion protection coating  
Three-layer coating with high mechanical and chemical resistance (polyurethane coating on two layers of epoxy coating)

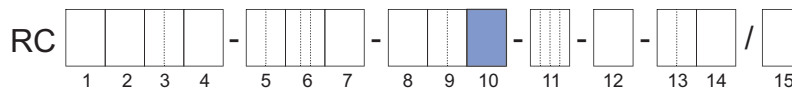

Housing material	Coating	Design	MS code Position 10	Bracket material
Aluminum Al-Si10Mg(Fe)	Standard coating	Integral type	0	–
		Remote type	A	Stainless steel 1.4301/304
	Corrosion protection coating	Integral type	2	–
		Remote type	E	Stainless steel 1.4301/304
Stainless Steel CF8M	–	Remote type	J	Stainless steel 1.4404/316L
	–			

See also *Design and housing* [▶ 85].

Nameplate

For stainless steel transmitter the nameplates are made of stainless steel 1.4404/316L. Sensor nameplates are made of foil.

### 6.3 Process connections, dimensions and weights of sensor

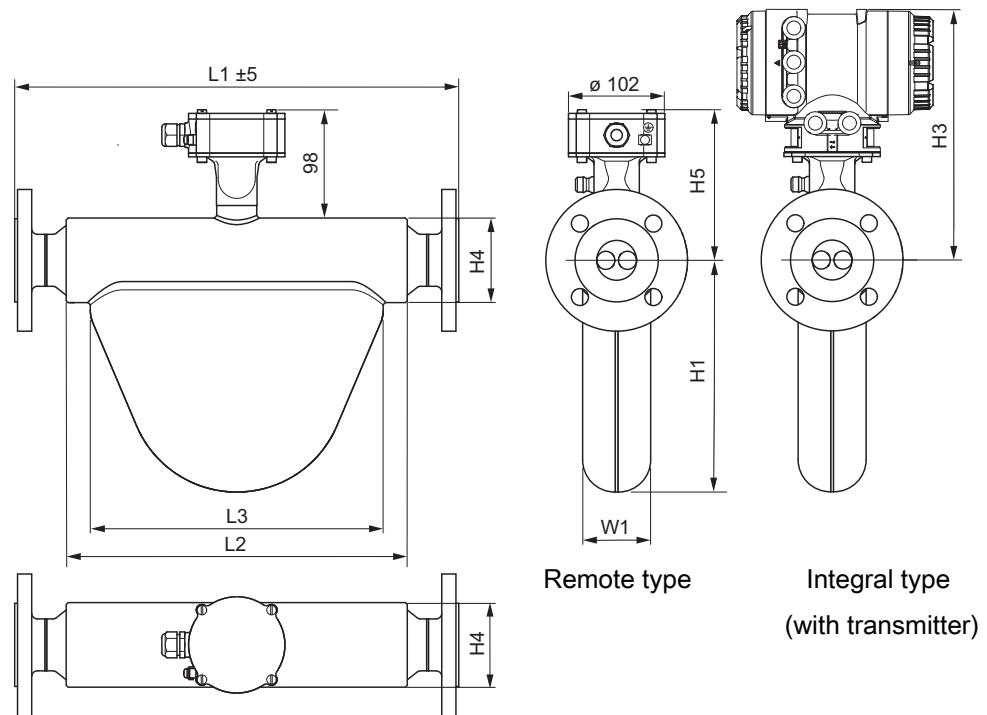

Fig. 21: Dimensions in mm

Tab. 16: Dimensions without length L1

Meter size	L2	L3	H1	H3	H4	H5	W1
	in mm (inch)						
Prime 25	190 (7.5)	165 (6.5)	117 (4.6)	268 (10.6)	56 (2.2)	138 (5.4)	42 (1.7)
Prime 40	227 (8.9)	195 (7.7)	145 (5.7)	277 (10.9)	71 (2.8)	148 (5.8)	50 (2)
Prime 50	361 (14.2)	310 (12.2)	245 (9.6)	289 (11.4)	90 (3.5)	159 (6.3)	72 (2.8)
Prime 80	455 (17.9)	400 (15.7)	333 (13.1)	296 (11.7)	102 (4)	167 (6.6)	96 (3.8)

#### Overall length L1 and weight

The overall length of the sensor depends on the selected process connection (type and size). The following tables list the overall length and weight as functions of the individual process connection.

The weights in the tables are for the remote type. Additional weight for the integral type: 3.5 kg (7.7 lb).

Process connections suitable for ASME B16.5

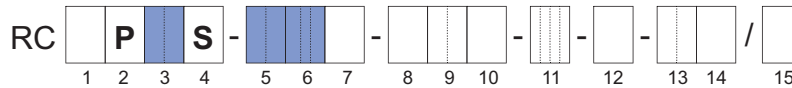

Tab. 17: Overall length L1 and weight of sensor (process connections: ASME)

Process connections	MS code pos.		Prime 25		Prime 40		Prime 50		Prime 80	
	5	6	L1 in mm (inch)	Weight in kg (lb)	L1 in mm (inch)	Weight in kg (lb)	L1 in mm (inch)	Weight in kg (lb)	L1 in mm (inch)	Weight in kg (lb)
ASME ½" class 150	15	BA1	280 (11)	6 (13)	320 (12.6)	8 (18)	-	-	-	-
ASME ½" class 300		BA2	280 (11)	6.4 (14)	320 (12.6)	8.4 (18)	-	-	-	-
ASME ½" class 600		BA4	290 (11.4)	6.6 (14)	330 (13)	8.6 (19)	-	-	-	-
ASME ½" class 600, ring joint		CA4	290 (11.4)	6.6 (15)	330 (13)	8.6 (19)	-	-	-	-
ASME 1" class 150	25	BA1	280 (11)	6.8 (15)	320 (12.6)	8.8 (19)	490 (19.3)	15.7 (35)	-	-
ASME 1" class 300		BA2	280 (11)	7.8 (17)	320 (12.6)	9.8 (22)	490 (19.3)	16.7 (37)	-	-
ASME 1" class 600		BA4	300 (11.8)	8.2 (18)	340 (13.4)	10.2 (23)	500 (19.7)	17 (38)	-	-
ASME 1" class 600, ring joint		CA4	300 (11.8)	8.3 (18)	340 (13.4)	10.3 (23)	500 (19.7)	17.2 (38)	-	-
ASME 1½" class 150	40	BA1	290 (11.4)	7.8 (17)	330 (13)	9.8 (22)	470 (18.5)	16.5 (36)	620 (24.4)	25.7 (57)
ASME 1½" class 300		BA2	290 (11.4)	10.1 (22)	330 (13)	12.1 (27)	480 (18.9)	18.8 (42)	620 (24.4)	28.1 (62)
ASME 1½" class 600		BA4	310 (12.2)	11.2 (25)	350 (13.8)	13.2 (29)	500 (19.7)	19.9 (44)	630 (24.8)	28.9 (64)
ASME 1½" class 600, ring joint		CA4	310 (12.2)	11.3 (25)	350 (13.8)	13.3 (29)	500 (19.7)	20 (44)	630 (24.8)	29.1 (64)
ASME 2" class 150	50	BA1	-	-	-	-	480 (18.9)	18.1 (40)	580 (22.8)	26.8 (59)
ASME 2" class 300		BA2	-	-	-	-	480 (18.9)	19.7 (43)	580 (22.8)	28.3 (62)
ASME 2" class 600		BA4	-	-	-	-	510 (20.1)	21.3 (47)	610 (24)	30.1 (66)
ASME 2" class 600, ring joint		CA4	-	-	-	-	510 (20.1)	21.5 (47)	610 (24)	30.2 (67)
ASME 2½" class 150	65	BA1	-	-	-	-	-	-	580 (22.8)	29.8 (66)
ASME 2½" class 300		BA2	-	-	-	-	-	-	580 (22.8)	31.1 (69)
ASME 2½" class 600		BA4	-	-	-	-	-	-	580 (22.8)	33.4 (74)
ASME 2½" class 600, ring joint		CA4	-	-	-	-	-	-	610 (24)	33.6 (74)



Process connections	MS code pos.		Prime 25		Prime 40		Prime 50		Prime 80	
	5	6	L1 in mm (inch)	Weight in kg (lb)	L1 in mm (inch)	Weight in kg (lb)	L1 in mm (inch)	Weight in kg (lb)	L1 in mm (inch)	Weight in kg (lb)
ASME 3" class 150	80	BA1	-	-	-	-	-	-	580 (22.8)	30.9 (68)
ASME 3" class 300		BA2	-	-	-	-	-	-	590 (23.2)	34.5 (76)
ASME 3" class 600		BA4	-	-	-	-	-	-	630 (24.8)	37.8 (83)
ASME 3" class 600, ring joint		CA4	-	-	-	-	-	-	610 (24)	37.5 (83)

Meaning of "-": not available

Process connections suitable for EN 1092-1

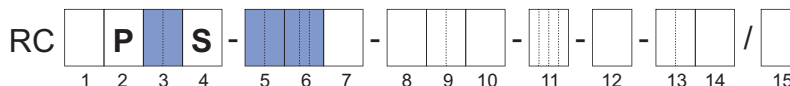

Tab. 18: Overall length L1 and weight of sensor (process connections: EN)

Process connections	MS code pos.		Prime 25		Prime 40		Prime 50		Prime 80	
	5	6	L1 in mm (inch)	Weight in kg (lb)	L1 in mm (inch)	Weight in kg (lb)	L1 in mm (inch)	Weight in kg (lb)	L1 in mm (inch)	Weight in kg (lb)
EN DN15 PN40, profile B1	15	BD4	280 (11)	6.6 (14)	320 (12.6)	8.6 (19)	-	-	-	-
EN DN15 PN40, profile D, with safety groove		GD4	280 (11)	6.4 (14)	320 (12.6)	8.4 (18)	-	-	-	-
EN DN15 PN40, profile E, with spigot		ED4	280 (11)	6.3 (14)	320 (12.6)	8.3 (18)	-	-	-	-
EN DN15 PN40, profile F, with recess		FD4	280 (11)	6.5 (14)	320 (12.6)	8.5 (19)	-	-	-	-
EN DN15 PN100, profile B1		BD6	290 (11.4)	7.4 (16)	330 (13)	9.4 (21)	-	-	-	-
EN DN15 PN100, profile D, with safety groove		GD6	290 (11.4)	7.4 (16)	330 (13)	9.4 (21)	-	-	-	-
EN DN15 PN100, profile E, with spigot		ED6	290 (11.4)	7.1 (16)	330 (13)	9.1 (20)	-	-	-	-
EN DN15 PN100, profile F, with recess		FD6	290 (11.4)	7.3 (16)	330 (13)	9.3 (21)	-	-	-	-
EN DN25 PN40, profile B1	25	BD4	280 (11)	7.5 (17)	320 (12.6)	9.5 (21)	490 (19.3)	16.4 (36)	-	-
EN DN25 PN40, profile D, with safety groove		GD4	280 (11)	7.5 (16)	320 (12.6)	9.5 (21)	490 (19.3)	16.3 (36)	-	-
EN DN25 PN40, profile E, with spigot		ED4	280 (11)	7.2 (16)	320 (12.6)	9.2 (20)	490 (19.3)	16.1 (35)	-	-
EN DN25 PN40, profile F, with recess		FD4	280 (11)	7.4 (16)	320 (12.6)	9.4 (21)	490 (19.3)	16.3 (36)	-	-
EN DN25 PN100, profile B1		BD6	300 (11.8)	10.1 (22)	340 (13.4)	12.1 (27)	490 (19.3)	18.8 (41)	-	-
EN DN25 PN100, profile D, with safety groove		GD6	300 (11.8)	10 (22)	340 (13.4)	12 (26)	490 (19.3)	18.7 (41)	-	-
EN DN25 PN100, profile E, with spigot		ED6	300 (11.8)	9.5 (21)	340 (13.4)	11.5 (25)	490 (19.3)	18.3 (40)	-	-
EN DN25 PN100, profile F, with recess		FD6	300 (11.8)	9.9 (22)	340 (13.4)	11.9 (26)	490 (19.3)	18.7 (41)	-	-

## Mechanical specification

Process connections	MS code pos.		Prime 25		Prime 40		Prime 50		Prime 80	
	5	6	L1 in mm (inch)	Weight in kg (lb)	L1 in mm (inch)	Weight in kg (lb)	L1 in mm (inch)	Weight in kg (lb)	L1 in mm (inch)	Weight in kg (lb)
EN DN40 PN40, profile B1	40	BD4	280 (11)	9.1 (20)	320 (12.6)	11.1 (24)	470 (18.5)	17.7 (39)	610 (24)	26.9 (59)
EN DN40 PN40, profile D, with safety groove		GD4	280 (11)	8.9 (20)	320 (12.6)	10.9 (24)	470 (18.5)	17.6 (39)	610 (24)	26.8 (59)
EN DN40 PN40, profile E, with spigot		ED4	280 (11)	8.6 (19)	320 (12.6)	10.6 (23)	470 (18.5)	17.4 (38)	610 (24)	26.5 (58)
EN DN40 PN40, profile F, with recess		FD4	280 (11)	8.8 (19)	320 (12.6)	10.8 (24)	470 (18.5)	17.5 (39)	610 (24)	26.7 (59)
EN DN40 PN100, profile B1		BD6	360 (14.2)	13.5 (30)	400 (15.7)	15.5 (34)	500 (19.7)	21.5 (47)	610 (24)	30.5 (67)
EN DN40 PN100, profile D, with safety groove		GD6	360 (14.2)	13.4 (30)	400 (15.7)	15.4 (34)	500 (19.7)	21.4 (47)	610 (24)	30.4 (67)
EN DN40 PN100, profile E, with spigot		ED6	360 (14.2)	13 (29)	400 (15.7)	15 (33)	500 (19.7)	21.1 (46)	610 (24)	30 (66)
EN DN40 PN100, profile F, with recess		FD6	360 (14.2)	13.3 (29)	400 (15.7)	15.3 (34)	500 (19.7)	21.3 (47)	610 (24)	30.3 (67)
EN DN50 PN40, profile B1	50	BD4	–	–	–	–	470 (18.5)	19.1 (42)	580 (22.8)	27.8 (61)
EN DN50 PN40, profile D, with safety groove		GD4	–	–	–	–	470 (18.5)	18.9 (42)	580 (22.8)	27.7 (61)
EN DN50 PN40, profile E, with spigot		ED4	–	–	–	–	470 (18.5)	18.6 (41)	580 (22.8)	27.4 (60)
EN DN50 PN40, profile F, with recess		FD4	–	–	–	–	470 (18.5)	18.8 (41)	580 (22.8)	27.6 (61)
EN DN50 PN100, profile B1		BD6	–	–	–	–	540 (21.3)	25.4 (56)	610 (24)	33.5 (74)
EN DN50 PN100, profile D, with safety groove		GD6	–	–	–	–	540 (21.3)	25.3 (56)	610 (24)	33.4 (74)
EN DN50 PN100, profile E, with spigot		ED6	–	–	–	–	540 (21.3)	24.8 (55)	610 (24)	32.9 (72)
EN DN50 PN100, profile F, with recess		FD6	–	–	–	–	540 (21.3)	25.2 (55)	610 (24)	33.2 (73)
EN DN80 PN40, profile B1	80	BD4	–	–	–	–	–	–	590 (23.2)	31.5 (69)
EN DN80 PN40, profile D, with safety groove		GD4	–	–	–	–	–	–	590 (23.2)	31.3 (69)
EN DN80 PN40, profile E, with spigot		ED4	–	–	–	–	–	–	590 (23.2)	30.9 (68)
EN DN80 PN40, profile F, with recess		FD4	–	–	–	–	–	–	590 (23.2)	31.1 (69)
EN DN80 PN100, profile B1		BD6	–	–	–	–	–	–	650 (25.6)	40 (88)
EN DN80 PN100, profile D, with safety groove		GD6	–	–	–	–	–	–	650 (25.6)	39.8 (88)
EN DN80 PN100, profile E, with spigot		ED6	–	–	–	–	–	–	650 (25.6)	39.2 (86)
EN DN80 PN100, profile F, with recess		FD6	–	–	–	–	–	–	650 (25.6)	39.6 (87)

Meaning of "–": not available

**Process connections suitable for JIS B 2220**

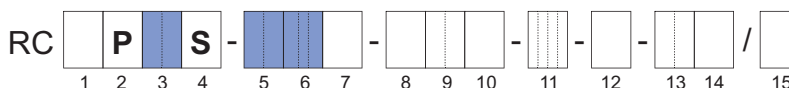

Tab. 19: Overall length L1 and weight of sensor (process connections: JIS)

Process connections	MS code pos.		Prime 25		Prime 40		Prime 50		Prime 80	
	5	6	L1 in mm (inch)	Weight in kg (lb)	L1 in mm (inch)	Weight in kg (lb)	L1 in mm (inch)	Weight in kg (lb)	L1 in mm (inch)	Weight in kg (lb)
JIS DN15 10K	15	BJ1	280 (11)	6.3 (14)	320 (12.6)	8.3 (18)	-	-	-	-
JIS DN15 20K		BJ2	280 (11)	6.5 (14)	320 (12.6)	8.5 (19)	-	-	-	-
JIS DN25 10K	25	BJ1	280 (11)	7.4 (16)	320 (12.6)	9.4 (21)	490 (19.3)	16.3 (36)	-	-
JIS DN25 20K		BJ2	280 (11)	7.8 (17)	320 (12.6)	9.8 (22)	490 (19.3)	16.6 (37)	-	-
JIS DN40 10K	40	BJ1	280 (11)	8.2 (18)	320 (12.6)	10.2 (23)	470 (18.5)	16.9 (37)	620 (24.4)	26.1 (58)
JIS DN40 20K		BJ2	280 (11)	8.6 (19)	320 (12.6)	10.6 (23)	470 (18.5)	17.3 (38)	620 (24.4)	26.5 (58)
JIS DN50 10K	50	BJ1	-	-	-	-	470 (18.5)	17.5 (39)	600 (23.6)	26.6 (59)
JIS DN50 20K		BJ2	-	-	-	-	470 (18.5)	17.7 (39)	600 (23.6)	26.7 (59)
JIS DN80 10K	80	BJ1	-	-	-	-	-	-	570 (22.4)	27.9 (62)
JIS DN80 20K		BJ2	-	-	-	-	-	-	580 (22.8)	30.4 (67)

Meaning of "-": not available

**Process connections suitable for JPI**

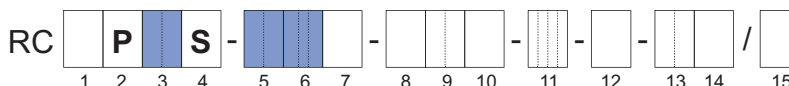

Tab. 20: Overall length L1 and weight of sensor (process connections: JPI)

Process connections	MS code pos.		Prime 25		Prime 40		Prime 50		Prime 80	
	5	6	L1 in mm (inch)	Weight in kg (lb)	L1 in mm (inch)	Weight in kg (lb)	L1 in mm (inch)	Weight in kg (lb)	L1 in mm (inch)	Weight in kg (lb)
JPI ½" class 150	15	BP1	280 (11)	5.9 (13)	320 (12.6)	7.9 (18)	-	-	-	-
JPI ½" class 300		BP2	280 (11)	6.4 (14)	320 (12.6)	8.4 (18)	-	-	-	-
JPI ½" class 600		BP4	290 (11.4)	6.6 (14)	330 (13)	8.6 (19)	-	-	-	-
JPI 1" class 150	25	BP1	280 (11)	6.7 (15)	320 (12.6)	8.7 (19)	490 (19.3)	15.7 (35)	-	-
JPI 1" class 300		BP2	280 (11)	7.8 (17)	320 (12.6)	9.8 (22)	490 (19.3)	16.7 (37)	-	-
JPI 1" class 600		BP4	300 (11.8)	8.2 (18)	340 (13.4)	10.2 (22)	500 (19.7)	17 (38)	-	-

Process connections	MS code pos.		Prime 25		Prime 40		Prime 50		Prime 80	
	5	6	L1 in mm (inch)	Weight in kg (lb)	L1 in mm (inch)	Weight in kg (lb)	L1 in mm (inch)	Weight in kg (lb)	L1 in mm (inch)	Weight in kg (lb)
JPI 1½" class 150	40	BP1	290 (11.4)	7.9 (17)	330 (13)	9.9 (22)	470 (18.5)	16.5 (36)	620 (24.4)	25.7 (57)
JPI 1½" class 300		BP2	290 (11.4)	10.1 (22)	330 (13)	12.1 (27)	480 (18.9)	18.9 (42)	620 (24.4)	28 (62)
JPI 1½" class 600		BP4	310 (12.2)	11.2 (25)	350 (13.8)	13.2 (29)	500 (19.7)	19.9 (44)	630 (24.8)	28.9 (64)
JPI 2" class 150	50	BP1	–	–	–	–	480 (18.9)	18.1 (40)	580 (22.8)	26.8 (59)
JPI 2" class 300		BP2	–	–	–	–	480 (18.9)	19.7 (43)	580 (22.8)	28.3 (62)
JPI 2" class 600		BP4	–	–	–	–	510 (20.1)	21.4 (47)	610 (24)	30.1 (66)
JPI 2½" class 150	65	BP1	–	–	–	–	–	–	580 (22.8)	29.5 (65)
JPI 2½" class 300		BP2	–	–	–	–	–	–	580 (22.8)	31.1 (68)
JPI 2½" class 600		BP4	–	–	–	–	–	–	610 (24)	33.2 (73)
JPI 3" class 150	80	BP1	–	–	–	–	–	–	580 (22.8)	30.9 (68)
JPI 3" class 300		BP2	–	–	–	–	–	–	590 (23.2)	34.5 (76)
JPI 3" class 600		BP4	–	–	–	–	–	–	610 (24)	37.3 (82)

Meaning of "–": not available

Process connections with internal thread

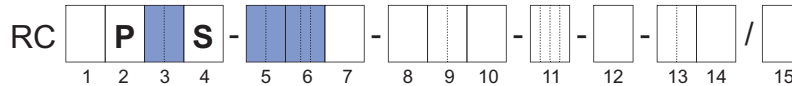

Tab. 21: Overall length L1 and weight of sensor (process connections: G thread)

Process connections	MS code pos.		Prime 25		Prime 40		Prime 50		Prime 80	
	5	6	L1 in mm (inch)	Weight in kg (lb)	L1 in mm (inch)	Weight in kg (lb)	L1 in mm (inch)	Weight in kg (lb)	L1 in mm (inch)	Weight in kg (lb)
G ¾"	08	TG9	300 (11.8)	5.4 (12)	–	–	–	–	–	–
G ½"	15		300 (11.8)	5.4 (12)	340 (13.4)	7.4 (16)	–	–	–	–
G ¾"	20		300 (11.8)	5.3 (12)	340 (13.4)	7.3 (16)	–	–	–	–

Meaning of "–": not available

Process connections with internal thread

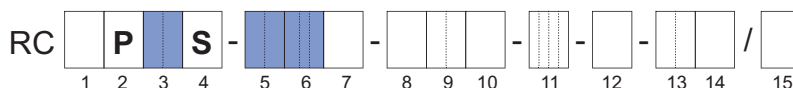

Tab. 22: Overall length L1 and weight of sensor (process connections: NPT thread)

Process connections	MS code pos.		Prime 25		Prime 40		Prime 50		Prime 80	
	5	6	L1 in mm (inch)	Weight in kg (lb)	L1 in mm (inch)	Weight in kg (lb)	L1 in mm (inch)	Weight in kg (lb)	L1 in mm (inch)	Weight in kg (lb)
NPT 3/8"	08	TT9	300 (11.8)	5.4 (12)	-	-	-	-	-	-
NPT 1/2"	15		300 (11.8)	5.4 (12)	340 (13.4)	7.4 (16)	-	-	-	-
NPT 3/4"	20		300 (11.8)	5.3 (12)	340 (13.4)	7.3 (16)	-	-	-	-

Meaning of "-": not available

6.4 Transmitter dimensions and weights

Transmitter dimensions

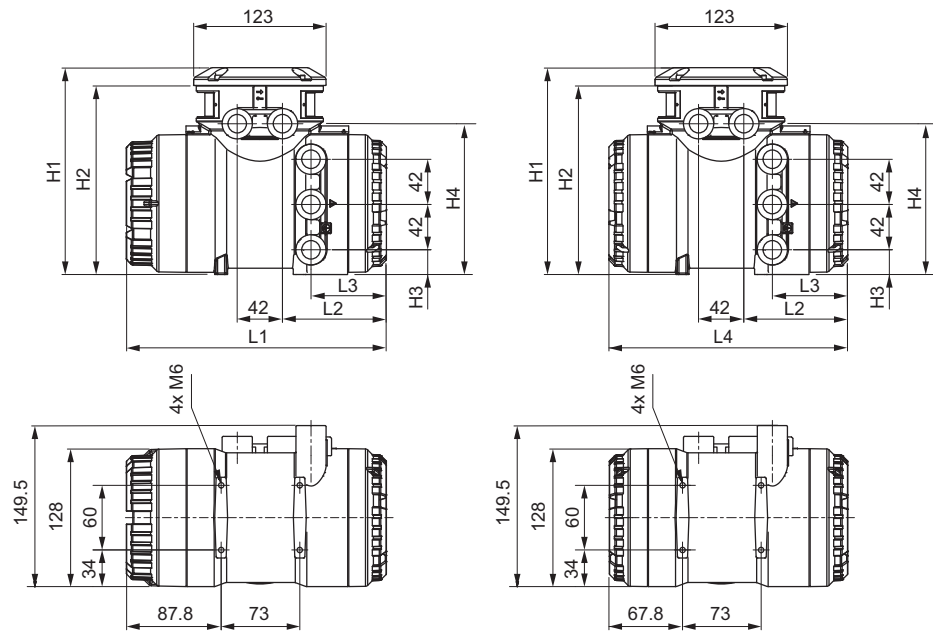

Fig. 22: Dimensions of transmitter in mm (left: transmitter with display, right: transmitter without display)

Material	L1 in mm (inch)	L2 in mm (inch)	L3 in mm (inch)	L4 in mm (inch)	H1 in mm (inch)	H2 in mm (inch)	H3 in mm (inch)	H4 in mm (inch)
Stainless steel	255.5 (10.06)	110.5 (4.35)	69 (2.72)	235 (9.25)	201 (7.91)	184 (7.24)	24 (0.94)	150.5 (5.93)
Aluminum	241.5 (9.51)	96.5 (3.8)	70 (2.76)	221 (8.7)	192 (7.56)	175 (6.89)	23 (0.91)	140 (5.51)

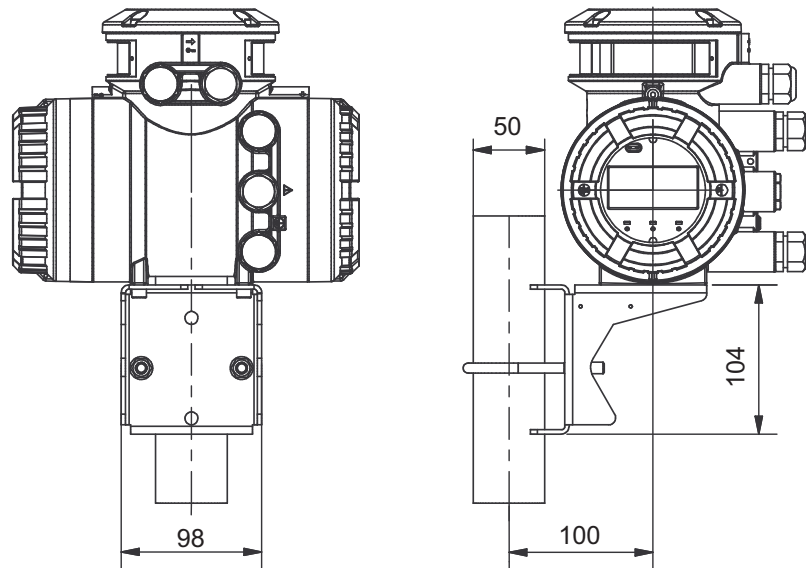
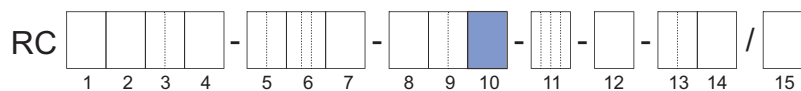

Fig. 23: Dimensions of transmitter in mm, attached by sheet metal console (bracket)



**Transmitter weights**

MS code (Position 10)	Design	Housing material of transmitter	Weight in kg (lb)
A, E	Remote	Aluminum	4.2 (9.3)
J		Stainless steel	12.5 (27.6)

## 7 Transmitter specification

Overview of functional scope of the Rotamass transmitter

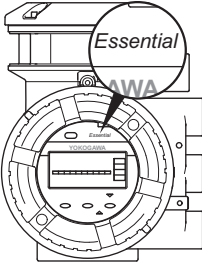
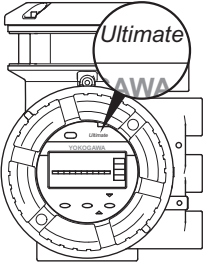
Functional scope	Transmitter	
	Essential	Ultimate
		
MS code (Position 1)	E	U
4-line Dot-Matrix display	•	•
Universal power supply ( $V_{DC}$ and $V_{AC}$ )	•	•
<b>Installation</b>		
Integral type	•	•
Remote type	•	•
<b>Special functions</b>		
Wizard	•	•
Event management	•	•
microSD card	•	•
Total-Health-Check	•	•
<b>Special functions for applications</b>		
Dynamic pressure compensation <sup>1)</sup>	–	•
Inline concentration measurement	–	•
Measurement of heat quantity <sup>1)</sup>	–	•
<b>Inputs and outputs</b>		
Analog output	•	•
Pulse/frequency output	•	•
Status output	•	•
Analog input	–	•
Status input	•	•
<b>Communication</b>		
HART	•	•
Modbus	•	•

<sup>1)</sup> Only in combination with an analog input



### 7.1 Inputs and outputs

Depending on the flow meter specification, there are different configurations of the connection terminal. Following are configuration examples of the connection terminal (value JK and M7 on MS code position 13 - see *Inputs and outputs* [▶ 86] for details):

#### HART

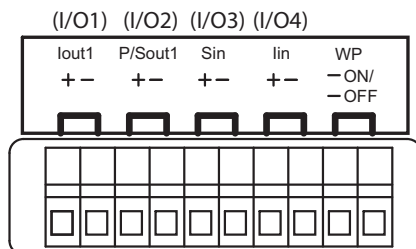

- I/O1: Current output (active/passive)  
Iout1
- I/O2: P/ Pulse or status output (passive)  
Sout1
- I/O3: Status input  
Sin
- I/O4: Iin Current input (active/passive)
- WP Write-protect bridge

#### Modbus

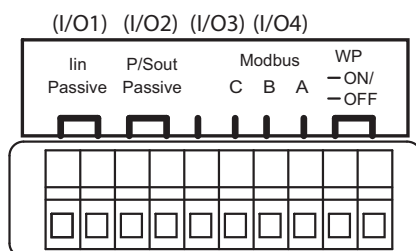

- I/O1: Iin Current input (passive)
- I/O2: P/ Pulse or status output (passive)  
Sout
- I/O3-I/ RS485 input/output  
O4:
- Modbus
- WP Write-protect bridge

7.1.1 Output signals

**Galvanic isolation** All circuits for inputs, outputs and power supply are galvanically isolated from each other.

**Active current output *lout*** One or two current outputs are available depending on MS code position 13. Depending on the measured value, the active current output delivers 4 - 20 mA.

It may be used for output of the following measured values:

- Flow rate (mass, volume, net partial component flow of a mixture)
- Density
- Temperature
- Pressure
- Concentration

For HART communication devices, it is supplied on the current output *lout1*. The current output may be operated in compliance with the NAMUR NE43 standard.

	Value
Nominal output current	4 – 20 mA
Maximum output current range	2.4 – 21.6 mA
Load resistance	≤ 750 Ω
Load resistance for secure HART communication	230 – 600 Ω
Additive maximum deviation	8 μA
Additive output deviation for deviation from 20 °C ambient temperature	0.8 μA/°C

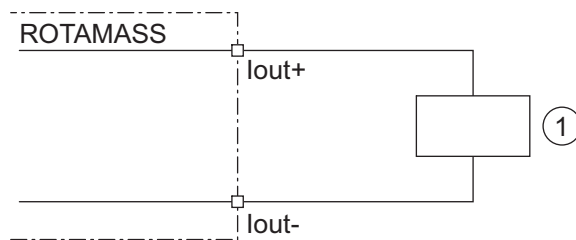

Fig. 24: Active current output connection *lout* HART

① Receiver

Passive current output *I<sub>out</sub>*

	Value
Nominal output current	4 – 20 mA
Maximum output current range	2.4 – 21.6 mA
External power supply	10.5 – 32 V <sub>DC</sub>
Load resistance for secure HART communication	230 – 600 Ω
Load resistance at current output	≤ 911 Ω
Additive maximum deviation	8 μA
Additive output deviation for deviation from 20 °C ambient temperature	0.8 μA/°C

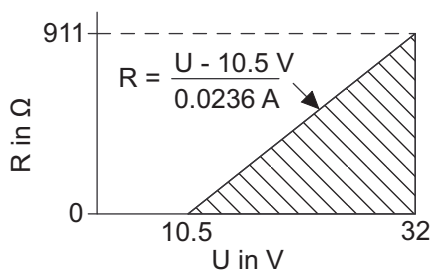

Fig. 25: Maximum load resistance as a function of an external power supply voltage

- R Load resistance
- U External power supply voltage

The diagram shows the maximum load resistance  $R$  as a function of voltage  $U$  of the connected voltage source. Higher load resistances are allowed with higher power supply values. The usable zone for passive power output operation is indicated by the hatched area.

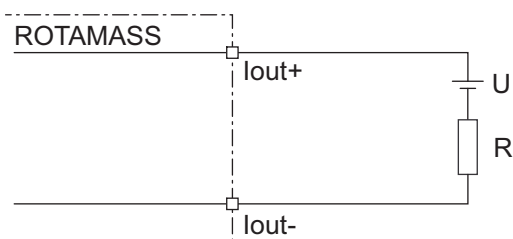

Fig. 26: Passive current output connection *I<sub>out</sub>*

**Active pulse output  
P/Sout**

**Connection of an electronic counter**

Maximum voltage and correct polarity must be observed for wiring.

	Value
Load resistance	> 1 kΩ
Internal power supply	24 V <sub>DC</sub> ±20 %
Maximum pulse rate	10000 pulses/s
Frequency range	0 – 12.5 kHz

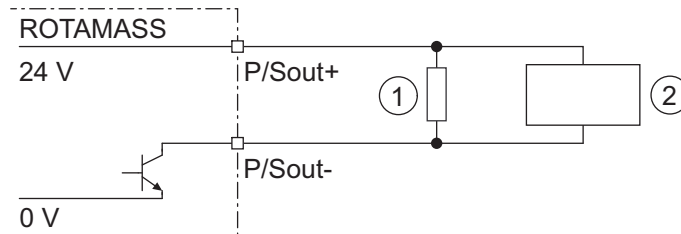

Fig. 27: Active pulse output connection P/Sout

- ① Load resistance
- ② Electronic counter

**Connection of an electromechanical counter**

	Value
Maximum current	150 mA
Average current	≤ 30 mA
Internal power supply	24 V <sub>DC</sub> ±20 %
Maximum pulse rate	2 pulses/s
Pulse width	20, 33, 50, 100 ms

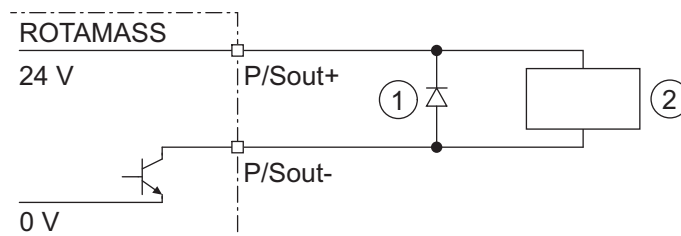

Fig. 28: Active pulse output P/Sout connection with electromechanical counter

- ① Protective diode
- ② Electromechanical counter

**Active pulse output P/Sout with internal pull-up resistor**

	Value
Internal power supply	24 V <sub>DC</sub> ±20 %
Internal pull-up resistor	2.2 kΩ
Maximum pulse rate	10000 pulses/s
Frequency range	0 – 12.5 kHz

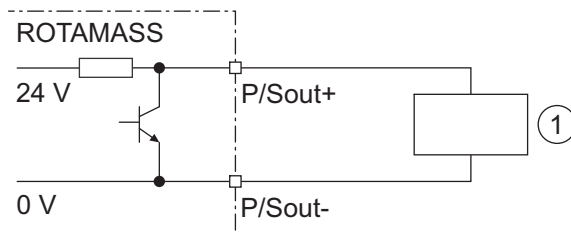

Fig. 29: Active pulse output P/Sout with internal pull-up resistor

- ① Electronic counter

**Passive pulse output P/Sout**

Maximum voltage and correct polarity must be observed for wiring.

	Value
Maximum load current	≤ 200 mA
Power supply	≤ 30 V <sub>DC</sub>
Maximum pulse rate	10000 pulses/s
Frequency range	0 – 12.5 kHz

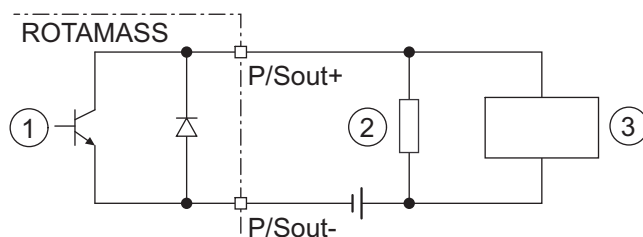

Fig. 30: Passive pulse output connection P/Sout with electronic counter

- ① Passive pulse or status output
- ② Load resistance
- ③ Electronic counter

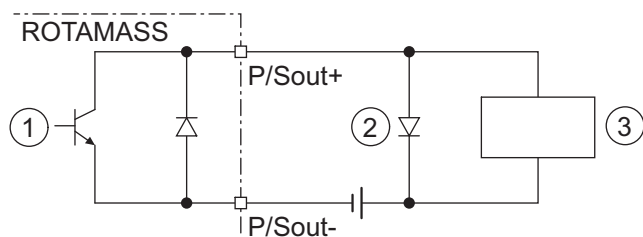

Fig. 31: Passive pulse output P/Sout connection with electromechanical counter

- ① Passive pulse or status output
- ② Protective diode
- ③ Electromechanical counter

**Active status output P/Sout**

Since this is a transistor contact, maximum allowed current as well as polarity and level of output voltage must be observed during wiring.

	Value
Load resistance	> 1 kΩ
Internal power supply	24 V <sub>DC</sub> ±20 %

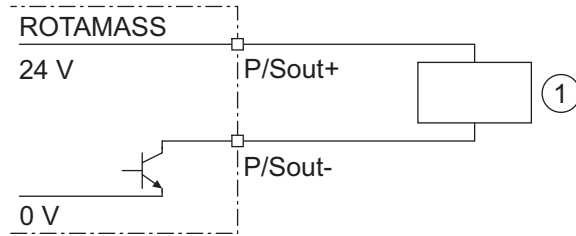

Fig. 32: Active status output connection P/Sout

① External device with load resistance

**Active status output P/Sout with internal pull-up resistor**

	Value
Internal pull-up resistor	2.2 kΩ
Internal power supply	24 V <sub>DC</sub> ±20 %

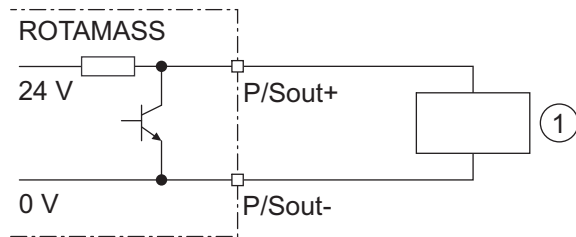

Fig. 33: Active status output P/Sout with internal pull-up resistor

① External device

**Passive status output P/Sout**

	Value
Output current	$\leq 200$ mA
Power supply	$\leq 30$ V <sub>DC</sub>

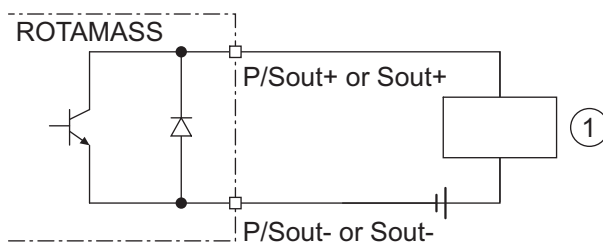

Fig. 34: Passive status output connection P/Sout

- ① External device

A relay must be connected in series to switch alternating voltage.

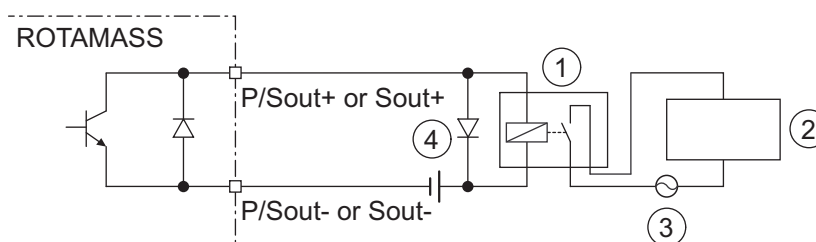

Fig. 35: Passive status output connection P/Sout for solenoid valve circuit

- ① Relay
- ② Solenoid valve
- ③ Magnetic valve power supply
- ④ Protective diode

**Passive pulse or status output P/Sout (NAMUR)**

According to EN 60947-5-6 (previously NAMUR, worksheet NA001)

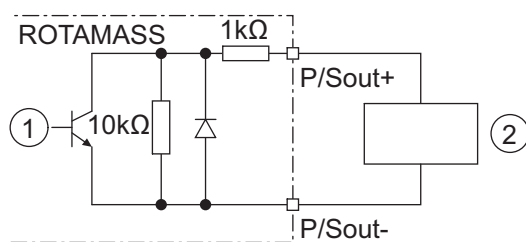

Fig. 36: Passive pulse or status output with switching amplifier connected in series

- ① Passive pulse or status output
- ② Switching amplifier

7.1.2 Input signals

**Active current input *lin*** An individual analog power input is available for external analog devices.

The active current input *lin* is provided for connecting a two-wire transmitter with an output signal of 4 – 20 mA.

	Value
Nominal input current	4 – 20 mA
Maximum input current range	2.4 – 21.6 mA
Internal power supply	24 V <sub>DC</sub> ±20 %
Internal load resistance Rotamass	≤ 160 Ω

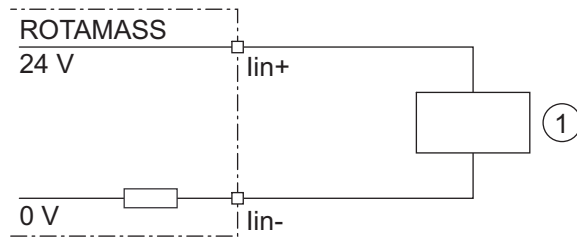

Fig. 37: Connection of external device with passive current output

① External passive current output device

**Passive current input *lin***

The passive current input *lin* is provided for connecting a four-wire transmitter with an output signal of 4 – 20 mA.

	Value
Nominal input current	4 – 20 mA
Maximum input current range	2.4 – 21.6 mA
Maximum input voltage	≤ 32 V <sub>DC</sub>
Internal load resistance Rotamass	≤ 160 Ω

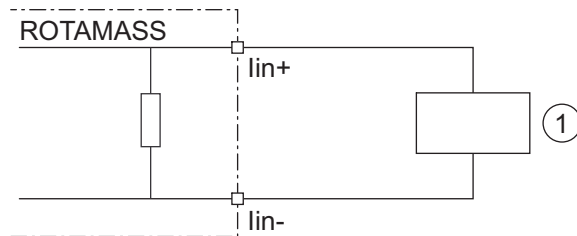

Fig. 38: Connection of external device with active current output

① External active current output device



Status input *Sin*

Do not connect a signal source with electric voltage.

The status input is provided for use of voltage-free contacts with the following specification:

Switching status	Resistance
Closed	< 200 $\Omega$
Open	> 100 k $\Omega$

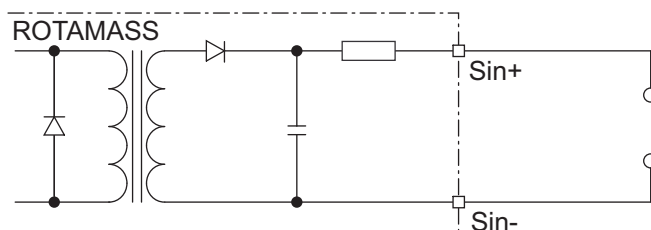

Fig. 39: Status input connection

## 7.2 Power supply

### Power supply

- Alternating voltage (rms):
  - Power supply<sup>1</sup>: 24 V<sub>AC</sub> or 100 – 240 V<sub>AC</sub>
  - Power frequency: 47 – 63 Hz
  - Power supply voltage tolerance: - 15 %, + 10 %
- Direct-current voltage:
  - Power supply<sup>1</sup>: 24 V<sub>DC</sub> or 100 – 120 V<sub>DC</sub>
  - Power supply voltage tolerance:  $\pm$  20 %

<sup>1</sup>for option MC<sub>-</sub> (DNV GL approval) supply voltage is limited to 24V

### Power consumption

- P = 10 W (including sensor)

### Power supply failure

In the event of a power failure, the flow meter data are backed up on a non-volatile internal memory. In case of devices with display, the characteristic sensor values, such as nominal diameter, serial number, calibration constants, Zero point, etc. and the error history are also stored on a microSD card.

## 7.3 Cable specification

With the remote type, the original connecting cable from Rota Yokogawa must be used to connect the sensor with the transmitter. The connecting cable included in the delivery may be shortened. An assembly set along with the appropriate instructions are enclosed for this purpose.

The connecting cable can be ordered in various lengths as a standard type (device options L<sub>---</sub>) or as marine approved fire retardant cable (device options Y<sub>---</sub>), see chapters *Connecting cable type and length* [▶ 89] and *Marine Approval* [▶ 96] for details.



The maximum cable length to keep the specification is 30 m (98.4 ft). Longer cables must be ordered as a separate item.

## 8 Approvals and declarations of conformity

<b>CE marking</b>	The Rotamass Coriolis flow meter meets the statutory requirements of the applicable EU Directives. By attaching the CE mark, Rota Yokogawa confirms conformity of the field instrument with the requirements of the applicable EU Directives. The EU Declaration of Conformity is enclosed with the product on a data carrier.
<b>RCM</b>	Rotamass Coriolis flow meter meets the EMC requirements of the Australian Communications and Media Authority (ACMA).
<b>Ex approvals</b>	All data relevant for explosion protection are included in separate Ex instruction manuals.
<b>Pressure equipment approvals</b>	The Rotamass Coriolis flow meter is in compliance with the statutory requirements of the applicable EU Pressure Equipment Directive (PED).

Tab. 23: Approvals and certifications

Type	Approval or certification
ATEX	EU Directive 2014/34/EU ATEX approval: DEKRA 15ATEX0023 X CE <sub>0344</sub> II2G or II2(1)G or II2D or II2(1)D Applied standards: <ul style="list-style-type: none"> <li>▪ EN 60079-0 +A11</li> <li>▪ EN 60079-1</li> <li>▪ EN 60079-7</li> <li>▪ EN 60079-11</li> <li>▪ EN 60079-31</li> </ul>
	Remote transmitter (depending on the MS code): Ex db [ia Ga] IIC T6 Gb or Ex db e [ia Ga] IIC T6 Gb or Ex db [ia Ga] IIB T6 Gb or Ex db e [ia Ga] IIB T6 Gb Ex db [ia Ga] [ia IIC Ga] IIB T6 Gb or Ex db e [ia Ga] [ia IIC Ga] IIB T6 Gb or Ex tb [ia Da] IIIC T75 °C Db
	Remote sensor (depending on the MS code): Ex ib IIC T6...T1 Gb or Ex ib IIB T6...T1 Gb Ex ib IIIC T200 °C Db
	Integral type (depending on the MS code): Ex db ib IIC T6...T1 Gb or Ex db e ib IIC T6...T1 Gb or Ex db ib IIB T6...T1 Gb or Ex db e ib IIB T6...T1 Gb or Ex db ib [ia Ga] IIC T6...T1 Gb or Ex db e ib [ia Ga] IIC T6...T1 Gb or Ex db ib [ia IIC Ga] IIB T6...T1 Gb or Ex db e ib [ia IIC Ga] IIB T6...T1 Gb Ex ib tb IIIC T150 °C Db or Ex ib tb [ia Da] IIIC T150 °C Db

Type	Approval or certification
IECEX	IECEx approval: IECEx DEK 15.0016X Applied standards: <ul style="list-style-type: none"> <li>▪ IEC 60079-0</li> <li>▪ IEC 60079-1</li> <li>▪ IEC 60079-7</li> <li>▪ IEC 60079-11</li> <li>▪ IEC 60079-31</li> </ul>
	Remote transmitter (depending on the MS code): Ex db [ia Ga] IIC T6 Gb or Ex db e [ia Ga] IIC T6 Gb or Ex db [ia Ga] IIB T6 Gb or Ex db e [ia Ga] IIB T6 Gb Ex db [ia Ga] [ia IIC Ga] IIB T6 Gb or Ex db e [ia Ga] [ia IIC Ga] IIB T6 Gb or Ex tb [ia Da] IIIC T75 °C Db
	Remote sensor (depending on the MS code): Ex ib IIC T6...T1 Gb or Ex ib IIB T6...T1 Gb Ex ib IIIC T200 °C Db
	Integral type (depending on the MS code): Ex db ib IIC T6...T1 Gb or Ex db e ib IIC T6...T1 Gb or Ex db ib IIB T6...T1 Gb or Ex db e ib IIB T6...T1 Gb or Ex db ib [ia Ga] IIC T6...T1 Gb or Ex db e ib [ia Ga] IIC T6...T1 Gb or Ex db ib [ia IIC Ga] IIB T6...T1 Gb or Ex db e ib [ia IIC Ga] IIB T6...T1 Gb Ex ib tb IIIC T150 °C Db or Ex ib tb [ia Da] IIIC T150 °C Db

Type	Approval or certification
FM (CA/US)	<p>FM approvals:</p> <ul style="list-style-type: none"> <li>▪ US Cert No. FM16US0095X</li> <li>▪ CA Cert No. FM16CA0031X</li> </ul> <p>Applied standards:</p> <ul style="list-style-type: none"> <li>▪ Class 3600</li> <li>▪ Class 3610</li> <li>▪ Class 3615</li> <li>▪ Class 3810</li> <li>▪ Class 3616</li> <li>▪ NEMA 250</li> <li>▪ ANSI/IEC 60529</li> <li>▪ CSA-C22.2 No. 0-10</li> <li>▪ CSA-C22.2 No. 0.4-04</li> <li>▪ CSA-C22.2 No. 0.5-1982</li> <li>▪ CSA-C22.2 No. 94.1-07</li> <li>▪ CSA-C22.2 No. 94.2-07</li> <li>▪ CAN/CSA-C22.2 No. 60079-0</li> <li>▪ CAN/CSA-C22.2 No. 60079-11</li> <li>▪ CAN/CSA-C22.2 No. 61010-1-04</li> <li>▪ CSA-C22.2 No. 25-1966</li> <li>▪ CSA-C22.2 No. 30-M1986</li> <li>▪ CSA-C22.2 No. 60529</li> </ul>
	<p>Remote transmitter (depending on the MS code):            CL I, DIV 1, GP ABCD, CL II/III, DIV 1, GP EFG; CL I ZN 1 GP IIC;            Associated Apparatus CL I/II/III DIV 1, GP ABCDEFG;            CL I ZN 0 GP IIC Entity Temperature class T6            or            CL I, DIV 1, GP ABCD, CL II/III, DIV 1, GP EFG; CL I ZN 1 GP IIC;            Associated Apparatus CL I/II/III DIV 1, GP ABCDEFG;            CL I ZN 0 GP IIC Temperature class T6;            Associated Apparatus CL I/II/III DIV 1, GP ABCDEFG;            CL I ZN 0 GP IIC Entity Temperature class T6            or            CL I, DIV 1, GP CD, CL II/III, DIV 1, GP EFG; CL I ZN 1 GP IIB;            Associated Apparatus CL I/II/III DIV 1, GP CDEFG;            CL I ZN 0 GP IIB Entity Temperature class T6            or            CL I, DIV 1, GP CD, CL II/III, DIV 1, GP EFG; CL I ZN 1 GP IIB;            Associated Apparatus CL I/II/III DIV 1, GP CDEFG;            CL I ZN 0 GP IIB Temperature class T6;            Associated Apparatus CL I/II/III DIV 1, GP ABCDEFG;            CL I ZN 0 GP IIB Entity Temperature class T6</p>
	<p>Remote sensor (depending on the MS code):            IS CL I/II/III, DIV 1, GP ABCDEFG;            CL I, ZN 0, GP IIC Temperature class T*            or            IS CL I/II/III, DIV 1, GP ABCDEFG;            CL I, ZN 0, GP IIB Temperature class T*</p>

Type	Approval or certification
FM (CA/US)	<p>Integral type (depending on the MS code):            CL I, DIV 1, GP ABCD, CL II/III, DIV 1, GP EFG;            CL I ZN 1 GP IIC Temperature class T*</p> <p>or</p> <p>CL I, DIV 1, GP ABCD, CL II/III, DIV 1, GP EFG; CL I ZN 1 GP IIC            Associated Apparatus CL I/II/III DIV 1 GP ABCDEFG;            CL I ZN 0 GP IIC Entity Temperature class T*</p> <p>or</p> <p>CL I, DIV 1, GP CD, CL II/III, DIV 1, GP EFG;            CL I ZN 1 GP IIB Temperature class T*</p> <p>or</p> <p>CL I, DIV 1, GP CD, CL II/III, DIV 1, GP EFG; CL I ZN 1 GP IIB            Associated Apparatus CL I/II/III DIV 1 GP ABCDEFG;            CL I ZN 0 GP IIC Entity Temperature class T*</p>
INMETRO	<p>INMETRO approval:            DEKRA 16.0012X</p> <p>Applied standards:</p> <ul style="list-style-type: none"> <li>▪ ABNT NBR IEC 60079-0</li> <li>▪ ABNT NBR IEC 60079-1</li> <li>▪ ABNT NBR IEC 60079-7</li> <li>▪ ABNT NBR IEC 60079-11</li> <li>▪ ABNT NBR IEC 60079-31</li> </ul>
	<p>Remote transmitter (depending on the MS code):            Ex db [ia Ga] IIC T6 Gb or            Ex db e [ia Ga] IIC T6 Gb or            Ex db [ia Ga] IIB T6 Gb or            Ex db e [ia Ga] IIB T6 Gb            Ex db [ia Ga] [ia IIC Ga] IIB T6 Gb or            Ex db e [ia Ga] [ia IIC Ga] IIB T6 Gb or            Ex tb [ia Da] IIIC T75 °C Db</p>
	<p>Remote sensor (depending on the MS code):            Ex ib IIC T6...T1 Gb or            Ex ib IIB T6...T1 Gb            Ex ib IIIC T200 °C Db</p>
	<p>Integral type (depending on the MS code):            Ex db ib IIC T6...T1 Gb or            Ex db e ib IIC T6...T1 Gb or            Ex db ib IIB T6...T1 Gb or            Ex db e ib IIB T6...T1 Gb or            Ex db ib [ia Ga] IIC T6...T1 Gb or            Ex db e ib [ia Ga] IIC T6...T1 Gb or            Ex db ib [ia IIC Ga] IIB T6...T1 Gb or            Ex db e ib [ia IIC Ga] IIB T6...T1 Gb            Ex ib tb IIIC T150 °C Db or            Ex ib tb [ia Da] IIIC T150 °C Db</p>

Type	Approval or certification
NEPSI	NEPSI approval GYJ17.1242X Applied standards: <ul style="list-style-type: none"> <li>▪ GB3836.1</li> <li>▪ GB3836.2</li> <li>▪ GB3836.3</li> <li>▪ GB3836.4</li> <li>▪ GB3836.19</li> <li>▪ GB3836.20</li> </ul>
	Remote transmitter (depending on the MS code): Ex db [ia Ga] IIC T6 Gb or Ex db e [ia Ga] IIC T6 Gb or Ex db [ia Ga] IIB T6 Gb or Ex db e [ia Ga] IIB T6 Gb Ex db [ia Ga] [ia IIC Ga] IIB T6 Gb or Ex db e [ia Ga] [ia IIC Ga] IIB T6 Gb or Ex tb [ia Da] IIIC T75 °C Db
	Remote sensor (depending on the MS code): Ex ib IIC T6...T1 Gb or Ex ib IIB T6...T1 Gb Ex ib IIIC T200 °C Db
	Integral type (depending on the MS code): Ex db ib IIC T6...T1 Gb or Ex db e ib IIC T6...T1 Gb or Ex db ib IIB T6...T1 Gb or Ex db e ib IIB T6...T1 Gb or Ex db ib [ia Ga] IIC T6...T1 Gb or Ex db e ib [ia Ga] IIC T6...T1 Gb or Ex db ib [ia IIC Ga] IIB T6...T1 Gb or Ex db e ib [ia IIC Ga] IIB T6...T1 Gb Ex ib tb IIIC T150 °C Db or Ex ib tb [ia Da] IIIC T150 °C Db

Type	Approval or certification
PESO	Certificate Number: DEKRA 15ATEX0023 X
	Equipment Reference Numbers: P400958/1 P400964/1 P400966/1 P400967/1 P400969/1 P400970/1 P400971/1 P400972/1 P400973/1
	Applied standards: <ul style="list-style-type: none"> <li>▪ EN 60079-0 +A11</li> <li>▪ IS/IEC 60079-1</li> <li>▪ EN 60079-11</li> </ul>
	Remote transmitter (depending on the MS code): Ex db [ia Ga] IIC T6 Gb or Ex db [ia Ga] IIB T6 Gb or Ex db [ia Ga] [ia IIC Ga] IIB T6 Gb
	Remote sensor (depending on the MS code): Ex ib IIC T6...T1 Gb or Ex ib IIB T6...T1 Gb
	Integral type (depending on the MS code): Ex db ib IIC T6...T1 Gb or Ex db ib IIB T6...T1 Gb or Ex db ib [ia Ga] IIC T6...T1 Gb or Ex db ib [ia IIC Ga] IIB T6...T1 Gb
Ingress protection	IP66/67 and NEMA 4X
EMC	EU directive 2014/30/EU per EN 61326-1 Class A Table 2 and EN 61326-2-3, IEC/EN 61000-3-2, IEC/EN 61000-3-3
	NAMUR NE21
	RCM in Australia/New Zealand
LVD	EU directive 2014/35/EU per EN 61010-1 and EN 61010-2-030
PED	EU directive 2014/68/EU per AD 2000 Code
Marine	DNV GL Type approval according to DNVGL-CP-0338 for options MC2 and MC3
RoHS	EU directive 2011/65/EU per EN 50581
SIL	Exida Certificate per IEC61508:2010 Parts 1-7 SIL 2 @ HFT=0; SIL 3 @ HFT =1

## 9 Ordering information

### 9.1 Overview MS code Prime 25

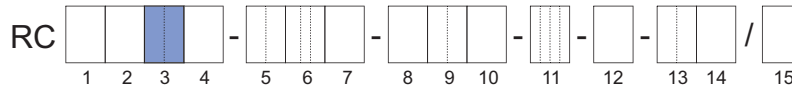

Model code Position	1.	2.	3.	4.	5.	6.	7.	8.	9.	10.	11.	12.	13.	14.	Description	Restriction
Transmitter	E														Essential (base function)	not with accuracy E3, E2, D7, D3, D2, C7, C3, C2, 50 not with communication type and I/O JH, JJ, JK, JL, JM, JN, M2, M7 not with option CST, AC_, CGC, C52
	U														Ultimate (high function)	not with accuracy E7, 70 not with display 0
Sensor	P														Prime	–
Meter size	25														Nominal mass flow : 1.6 t/h (59 lb/min) Maximum mass flow: 2.3 t/h (85 lb/min)	–
Material wetted parts	S														Stainless steel 1.4404/316L	–
Process connection size	08														¾"	–
	15														DN15, ½"	
	20														DN20, ¾"	
	25														DN25, 1"	
	40														DN40, 1½"	
Process connection type	BA1														ASME flange class 150, suitable for ASME B16.5	see table on page [ 40]
	BA2														ASME flange class 300, suitable for ASME B16.5	
	BA4														ASME flange class 600, suitable for ASME B16.5	
	CA4														ASME flange class 600, suitable for ASME B16.5, ring joint	
	BD4														EN flange PN 40, suitable for EN 1092-1 form B1	not with option WPA, RTA, PTA, P20 see table on page [ 41] and the following pages
	ED4														EN flange PN 40, suitable for EN 1092-1 form E, spigot	
	FD4														EN flange PN 40, suitable for EN 1092-1 form F, recess	
	GD4														EN flange PN 40, suitable for EN 1092-1 form D, safety grooves	
	BD6														EN flange PN 100, suitable for EN 1092-1 form B1	
	ED6														EN flange PN 100, suitable for EN 1092-1 form E, spigot	
	FD6														EN flange PN 100, suitable for EN 1092-1 form F, recess	
	GD6														EN flange PN 100, suitable for EN 1092-1 form D, safety grooves	
	BJ1														JIS flange 10K, JIS B 2220	not with option WPA, RTA, PTA, P20 see table on page [ 43]
	BJ2														JIS flange 20K, JIS B 2220	
BP1														JPI flange class 150	not with option WPA, RTA, PTA, P20	
BP2														JPI flange class 300	see table on page [ 43]	
BP4														JPI flange class 600		
TG9														Process connection with internal thread G	not with option WPA, RTA, PTA, P20 see table on page [ 44]	
TT9														Process connection with internal thread NPT	not with option WPA, RTA, PTA, P20 see table on page [ 45]	
Sensor housing material	0														Stainless steel 1.4301/304, 1.4404/316L	–
Medium temperature range	0														Standard, integral type: -50 – 150 °C (-58 – 302 °F), remote type: -70 – 200 °C (-94 – 392 °F)	–



Model code Position	1.	2.	3.	4.	5.	6.	7.	8.	9.	10.	11.	12.	13.	14.	Description	Restriction
Mass flow and density accuracy										E7					Liquid: 0.2 % maximum mass flow deviation $D_{flat}$ , 4 g/l density deviation	not with transmitter U
										E3					Liquid: 0.2 % maximum mass flow deviation $D_{flat}$ , 1 g/l density deviation	not with transmitter E
										E2					Liquid: 0.2 % maximum mass flow deviation $D_{flat}$ , 0.5 g/l density deviation	
										D7					Liquid: 0.15 % maximum mass flow deviation $D_{flat}$ , 4 g/l density deviation	
										D3					Liquid: 0.15 % maximum mass flow deviation $D_{flat}$ , 1 g/l density deviation	
										D2					Liquid: 0.15 % maximum mass flow deviation $D_{flat}$ , 0.5 g/l density deviation	
										C7					Liquid: 0.1 % maximum mass flow deviation $D_{flat}$ , 4 g/l density deviation	
										C3					Liquid: 0.1 % maximum mass flow deviation $D_{flat}$ , 1 g/l density deviation	
										C2					Liquid: 0.1 % maximum mass flow deviation $D_{flat}$ , 0.5 g/l density deviation	
										70					Gas: 0.75 % maximum mass flow deviation $D_{flat}$	not with transmitter U not with option CST, AC_, C52
									50					Gas: 0.5 % maximum mass flow deviation $D_{flat}$	not with transmitter E not with option CST, AC_, C52	
Design and housing										0					Integral type with "urethane-cured polyester powder coating" coated aluminum transmitter housing	not with option L_..., MC_, Y_...
										2					Integral type with "corrosion protection coating" coated aluminum transmitter housing	not with option RB
										A					Remote type with "urethane-cured polyester powder coating" coated aluminum transmitter housing and standard neck sensor	
										E					Remote type with "corrosion protection coating" coated aluminum transmitter housing and standard neck sensor	
										J					Remote type stainless steel transmitter and standard neck sensor	
Ex approval										NN00					None	not with communication type and I/O JP, JQ, JR, JS not with option EPT
										KF21					ATEX, explosion group IIC and IIIC	not with design and housing J
										KF22					ATEX, explosion group IIB and IIIC	–
										SF21					IECEx, explosion group IIC and IIIC	not with design and housing J
										SF22					IECEx, explosion group IIB and IIIC	–
										FF11					FM, groups A, B, C, D, E, F, G	not with cable entries 4
										FF12					FM, groups C, D, E, F, G	not with option Y_...
										UF21					INMETRO, explosion group IIC and IIIC	not with Design and housing J not with option Y_...
										UF22					INMETRO, explosion group IIB and IIIC	not with option Y_...
										NF21					NEPSI, explosion group IIC and IIIC	not with Design and housing J not with option Y_... only with option CN
										NF22					NEPSI, explosion group IIB and IIIC	not with option Y_... only with option CN
	Cable entries										2					ANSI 1/2" NPT
									4					ISO M20x1.5	not with Ex approval FF11 or FF12	

Model code	1.	2.	3.	4.	5.	6.	7.	8.	9.	10.	11.	12.	13.	14.	Description	Restriction	
Position																	
Communication type and I/O														JA	1 active current output HART, 1 passive pulse or status output	not with option CGC, C52	
														JB	2 active current outputs one with HART, 2 passive pulse or status outputs		
														JC	2 active current outputs one with HART, 1 passive pulse or status output, 1 voltage-free status input		
														JD	1 active current output HART, 2 passive pulse or status outputs, 1 passive status output		
														JE	1 active current output HART, 2 passive pulse or status outputs, 1 voltage-free status input		
														JF	1 active current output HART, 1 passive pulse or status output, 1 active pulse or status output with pull-up resistor, 1 voltage-free status input		
														JG	1 active current output HART, 1 passive pulse or status output, 1 active pulse or status output, 1 voltage-free status input		
														JH	1 active current output HART, 1 passive pulse or status output, 1 passive current output, 1 active current input	not with transmitter E, not with option C52	
														JJ	1 active current output HART, 2 passive pulse or status outputs, 1 active current input		
														JK	1 active current output HART, 1 passive pulse or status output, 1 voltage-free status input, 1 active current input		
														JL	1 active current output HART, 1 passive pulse or status output, 1 passive current output, 1 passive current input		
														JM	1 active current output HART, 2 passive pulse or status outputs, 1 passive current input		
														JN	1 active current output HART, 1 passive pulse or status output, 1 voltage-free status input, 1 passive current input		
														JP	2 passive current outputs one with HART, 1 passive pulse or status output		
														JQ	2 passive current outputs one with HART, 2 passive pulse or status outputs	not with Ex approval NN00 not with option CGC, C52, MC2, MC3	
														JR	2 passive current outputs one with HART, 1 passive NAMUR pulse or status output		
														JS	2 passive current outputs one with HART, 2 passive NAMUR pulse or status outputs		
														M0	Modbus output, 1 passive pulse or status output	not with option CGC, PS	
														M2	Modbus output, 1 passive pulse or status output, 1 active current input	not with transmitter E, not with option PS	
														M3	Modbus output, 2 passive pulse or status outputs	not with option CGC , PS	
														M4	Modbus output, 1 passive pulse or status output, 1 active pulse or status output		
														M5	Modbus output, 1 passive pulse or status output, 1 active pulse or status output with pull-up resistor		
														M6	Modbus output, 1 passive pulse or status output, 1 active current output		
														M7	Modbus output, 1 passive pulse or status output, 1 passive current input	not with transmitter E, not with option PS	
	Display														0	No display	not with transmitter U
															1	With display	-

### 9.2 Overview MS code Prime 40

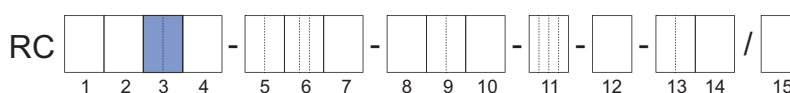

Model code Position	1.	2.	3.	4.	5.	6.	7.	8.	9.	10.	11.	12.	13.	14.	Description	Restriction
Transmitter	E														Essential (base function)	not with accuracy E3, E2, D7, D3, D2, C7, C3, C2, 50 not with communication type and I/O JH, JJ, JK, JL, JM, JN, M2, M7
	U														Ultimate (high function)	not with accuracy E7, 70 not with display 0
Sensor	P														Prime	–
Meter size	40														Nominal mass flow : 4.7 t/h (170 lb/min) Maximum mass flow: 7 t/h (260 lb/min)	–
Material wetted parts	S														Stainless steel 1.4404/316L	–
Process connection size	15														DN15, ½"	–
	20														DN20, ¾"	
	25														DN25, 1"	
	40														DN40, 1½"	
Process connection type	BA1														ASME flange class 150, suitable for ASME B16.5	see table on page [ 40 ]
	BA2														ASME flange class 300, suitable for ASME B16.5	
	BA4														ASME flange class 600, suitable for ASME B16.5	
	CA4														ASME flange class 600, suitable for ASME B16.5, ring joint	
	BD4														EN flange PN 40, suitable for EN 1092-1 form B1	not with option WPA, RTA, PTA, P20
	ED4														EN flange PN 40, suitable for EN 1092-1 form E, spigot	
	FD4														EN flange PN 40, suitable for EN 1092-1 form F, recess	
	GD4														EN flange PN 40, suitable for EN 1092-1 form D, safety grooves	
	BD6														EN flange PN 100, suitable for EN 1092-1 form B1	
	ED6														EN flange PN 100, suitable for EN 1092-1 form E, spigot	
	FD6														EN flange PN 100, suitable for EN 1092-1 form F, recess	
	GD6														EN flange PN 100, suitable for EN 1092-1 form D, safety grooves	
	BJ1														JIS flange 10K, JIS B 2220	not with option WPA, RTA, PTA, P20
	BJ2														JIS flange 20K, JIS B 2220	see table on page [ 43 ]
BP1														JPI flange class 150	not with option WPA, RTA, PTA, P20	
BP2														JPI flange class 300	see table on page [ 43 ]	
BP4														JPI flange class 600	see table on page [ 43 ]	
TG9														Process connection with internal thread G	not with option WPA, RTA, PTA, P20 see table on page [ 44 ]	
TT9														Process connection with internal thread NPT	not with option WPA, RTA, PTA, P20 see table on page [ 45 ]	
Sensor housing material	0														Stainless steel 1.4301/304, 1.4404/316L	–
Medium temperature range	0														Standard, integral type: -50 – 150 °C (-58 – 302 °F), remote type: -70 – 200 °C (-94 – 392 °F)	–

Model code Position	1.	2.	3.	4.	5.	6.	7.	8.	9.	10.	11.	12.	13.	14.	Description	Restriction
Mass flow and density accuracy										E7	Liquid: 0.2 % maximum mass flow deviation $D_{\text{flat}}$ , 4 g/l density deviation				not with transmitter U	
										E3	Liquid: 0.2 % maximum mass flow deviation $D_{\text{flat}}$ , 1 g/l density deviation				not with transmitter E	
										E2	Liquid: 0.2 % maximum mass flow deviation $D_{\text{flat}}$ , 0.5 g/l density deviation					
										D7	Liquid: 0.15 % maximum mass flow deviation $D_{\text{flat}}$ , 4 g/l density deviation					
										D3	Liquid: 0.15 % maximum mass flow deviation $D_{\text{flat}}$ , 1 g/l density deviation					
										D2	Liquid: 0.15 % maximum mass flow deviation $D_{\text{flat}}$ , 0.5 g/l density deviation					
										C7	Liquid: 0.1 % maximum mass flow deviation $D_{\text{flat}}$ , 4 g/l density deviation					
										C3	Liquid: 0.1 % maximum mass flow deviation $D_{\text{flat}}$ , 1 g/l density deviation					
										C2	Liquid: 0.1 % maximum mass flow deviation $D_{\text{flat}}$ , 0.5 g/l density deviation					
										70	Gas: 0.75 % maximum mass flow deviation $D_{\text{flat}}$				not with transmitter U not with option CST, AC_, C52	
										50	Gas: 0.5 % maximum mass flow deviation $D_{\text{flat}}$				not with transmitter E not with option CST, AC_, C52	
Design and housing										0	Integral type with "urethane-cured polyester powder coating" coated aluminum transmitter housing				not with option L_..., MC_, Y_...	
										2	Integral type with "corrosion protection coating" coated aluminum transmitter housing				not with option RB	
										A	Remote type with "urethane-cured polyester powder coating" coated aluminum transmitter housing and standard neck sensor					
										E	Remote type with "corrosion protection coating" coated aluminum transmitter housing and standard neck sensor					
										J	Remote type stainless steel transmitter and standard neck sensor				not with Ex approval KF21, SF21, UF21, NF21, QF21 not with option RB	
Ex approval										NN00	None				not with communication type and I/O JP, JQ, JR, JS not with option EPT	
										KF21	ATEX, explosion group IIC and IIIC				not with design and housing J	
										KF22	ATEX, explosion group IIB and IIIC				–	
										SF21	IECEX, explosion group IIC and IIIC				not with design and housing J	
										SF22	IECEX, explosion group IIB and IIIC				–	
										FF11	FM, groups A, B, C, D, E, F, G				not with cable entries 4	
										FF12	FM, groups C, D, E, F, G				not with option Y_...	
										UF21	INMETRO, explosion group IIC and IIIC				not with Design and housing J not with option Y_...	
										UF22	INMETRO, explosion group IIB and IIIC				not with option Y_...	
										NF21	NEPSI, explosion group IIC and IIIC				not with Design and housing J not with option Y_... only with option CN	
										NF22	NEPSI, explosion group IIB and IIIC				not with option Y_... only with option CN	
	Cable entries										QF21	PESO, explosion group IIC				not with design and housing J not with option: Y_...
									QF22	PESO, explosion group IIB				not with option Y_...		
									2	ANSI ½" NPT				–		
									4	ISO M20x1.5				not with Ex approval FF11 or FF12		

Model code Position	1.	2.	3.	4.	5.	6.	7.	8.	9.	10.	11.	12.	13.	14.	Description	Restriction	
Communication type and I/O													JA		1 active current output HART, 1 passive pulse or status output	not with option CGC, C52	
													JB		2 active current outputs one with HART, 2 passive pulse or status outputs		
													JC		2 active current outputs one with HART, 1 passive pulse or status output, 1 voltage-free status input		
													JD		1 active current output HART, 2 passive pulse or status outputs, 1 passive status output		
													JE		1 active current output HART, 2 passive pulse or status outputs, 1 voltage-free status input		
													JF		1 active current output HART, 1 passive pulse or status output, 1 active pulse or status output with pull-up resistor, 1 voltage-free status input		
													JG		1 active current output HART, 1 passive pulse or status output, 1 active pulse or status output, 1 voltage-free status input		
														JH		1 active current output HART, 1 passive pulse or status output, 1 passive current output, 1 active current input	not with transmitter E, not with option C52
														JJ		1 active current output HART, 2 passive pulse or status outputs, 1 active current input	
														JK		1 active current output HART, 1 passive pulse or status output, 1 voltage-free status input, 1 active current input	
														JL		1 active current output HART, 1 passive pulse or status output, 1 passive current output, 1 passive current input	
														JM		1 active current output HART, 2 passive pulse or status outputs, 1 passive current input	
														JN		1 active current output HART, 1 passive pulse or status output, 1 voltage-free status input, 1 passive current input	
														JP		2 passive current outputs one with HART, 1 passive pulse or status output	
																2 passive current outputs one with HART, 2 passive pulse or status outputs	not with Ex approval NN00 not with option CGC, C52, MC2, MC3
														JR		2 passive current outputs one with HART, 1 passive NAMUR pulse or status output	
														JS		2 passive current outputs one with HART, 2 passive NAMUR pulse or status outputs	
														M0		Modbus output, 1 passive pulse or status output	not with option CGC, PS
														M2		Modbus output, 1 passive pulse or status output, 1 active current input	not with transmitter E, not with option PS
														M3		Modbus output, 2 passive pulse or status outputs	not with option CGC , PS
														M4		Modbus output, 1 passive pulse or status output, 1 active pulse or status output	
													M5		Modbus output, 1 passive pulse or status output, 1 active pulse or status output with pull-up resistor		
													M6		Modbus output, 1 passive pulse or status output, 1 active current output		
													M7		Modbus output, 1 passive pulse or status output, 1 passive current input	not with transmitter E, not with option PS	
Display													0		No display	not with transmitter U	
													1		With display	–	

9.3 Overview MS code Prime 50

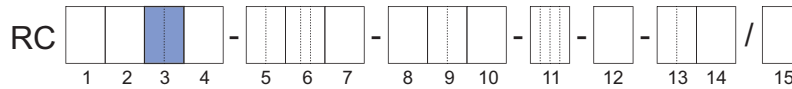

Model code Position	1.	2.	3.	4.	5.	6.	7.	8.	9.	10.	11.	12.	13.	14.	Description	Restriction
Transmitter	E														Essential (base function)	not with accuracy E3, E2, D7, D3, D2, C7, C3, C2, 50 not with communication type and I/O JH, JJ, JK, JL, JM, JN, M2, M7 not with option CST, AC_, CGC, C52
	U														Ultimate (high function)	not with accuracy E7, 70 not with display 0
Sensor	P														Prime	–
Meter size	50														Nominal mass flow : 20 t/h (730 lb/min) Maximum mass flow: 29 t/h (1100 lb/min)	–
Material wetted parts	S														Stainless steel 1.4404/316L	–
Process connection size	25														DN25, 1"	–
	40														DN40, 1½"	
	50														DN50, 2"	
Process connection type	BA1														ASME flange class 150, suitable for ASME B16.5	see table on page [ 40]
	BA2														ASME flange class 300, suitable for ASME B16.5	
	BA4														ASME flange class 600, suitable for ASME B16.5	
	CA4														ASME flange class 600, suitable for ASME B16.5, ring joint	
	BD4														EN flange PN 40, suitable for EN 1092-1 form B1	not with option WPA, RTA, PTA, P20 see table on page [ 41] and the following pages
	ED4														EN flange PN 40, suitable for EN 1092-1 form E, spigot	
	FD4														EN flange PN 40, suitable for EN 1092-1 form F, recess	
	GD4														EN flange PN 40, suitable for EN 1092-1 form D, safety grooves	
	BD6														EN flange PN 100, suitable for EN 1092-1 form B1	
	ED6														EN flange PN 100, suitable for EN 1092-1 form E, spigot	
	FD6														EN flange PN 100, suitable for EN 1092-1 form F, recess	
	GD6														EN flange PN 100, suitable for EN 1092-1 form D, safety grooves	
	BJ1														JIS flange 10K, JIS B 2220	not with option WPA, RTA, PTA, P20
	BJ2														JIS flange 20K, JIS B 2220	see table on page [ 43]
BP1														JPI flange class 150	not with option WPA, RTA, PTA, P20	
BP2														JPI flange class 300	see table on page [ 43]	
BP4														JPI flange class 600		
Sensor housing material	0														Stainless steel 1.4301/304, 1.4404/316L	–
Medium temperature range	0														Standard, integral type: -50 – 150 °C (-58 – 302 °F), remote type: -70 – 200 °C (-94 – 392 °F)	–
Mass flow and density accuracy	E7														Liquid: 0.2 % maximum mass flow deviation $D_{\text{rat}}$ , 4 g/l density deviation	not with transmitter U
	E3														Liquid: 0.2 % maximum mass flow deviation $D_{\text{rat}}$ , 1 g/l density deviation	not with transmitter E
	E2														Liquid: 0.2 % maximum mass flow deviation $D_{\text{rat}}$ , 0.5 g/l density deviation	
	D7														Liquid: 0.15 % maximum mass flow deviation $D_{\text{rat}}$ , 4 g/l density deviation	
	D3														Liquid: 0.15 % maximum mass flow deviation $D_{\text{rat}}$ , 1 g/l density deviation	
	D2														Liquid: 0.15 % maximum mass flow deviation $D_{\text{rat}}$ , 0.5 g/l density deviation	
	C7														Liquid: 0.1 % maximum mass flow deviation $D_{\text{rat}}$ , 4 g/l density deviation	
	C3														Liquid: 0.1 % maximum mass flow deviation $D_{\text{rat}}$ , 1 g/l density deviation	
	C2														Liquid: 0.1 % maximum mass flow deviation $D_{\text{rat}}$ , 0.5 g/l density deviation	
	70														Gas: 0.75 % maximum mass flow deviation $D_{\text{rat}}$	not with transmitter U not with option CST, AC_, C52
50														Gas: 0.5 % maximum mass flow deviation $D_{\text{rat}}$	not with transmitter E not with option CST, AC_, C52	

Model code	1.	2.	3.	4.	5.	6.	7.	8.	9.	10.	11.	12.	13.	14.	Description	Restriction
Position																
Design and housing											0	Integral type with "urethane-cured polyester powder coating" coated aluminum transmitter housing	not with option L____, MC_, Y____			
											2	Integral type with "corrosion protection coating" coated aluminum transmitter housing				
											A	Remote type with "urethane-cured polyester powder coating" coated aluminum transmitter housing and standard neck sensor	not with option RB			
											E	Remote type with "corrosion protection coating" coated aluminum transmitter housing and standard neck sensor				
											J	Remote type stainless steel transmitter and standard neck sensor	not with Ex approval KF21, SF21, UF21, NF21, QF21 not with option RB			
Ex approval											NN00	None	not with communication type and I/O JP, JQ, JR, JS not with option EPT			
											KF21	ATEX, explosion group IIC and IIIC	not with design and housing J			
											KF22	ATEX, explosion group IIB and IIIC	–			
											SF21	IECEX, explosion group IIC and IIIC	not with design and housing J			
											SF22	IECEX, explosion group IIB and IIIC	–			
											FF11	FM, groups A, B, C, D, E, F, G	not with cable entries 4			
											FF12	FM, groups C, D, E, F, G	not with option Y____			
											UF21	INMETRO, explosion group IIC and IIIC	not with Design and housing J not with option Y____			
											UF22	INMETRO, explosion group IIB and IIIC	not with option Y____			
											NF21	NEPSI, explosion group IIC and IIIC	not with Design and housing J not with option Y____ only with option CN			
											NF22	NEPSI, explosion group IIB and IIIC	not with option Y____ only with option CN			
											QF21	PESO, explosion group IIC	not with design and housing J not with option: Y____			
											QF22	PESO, explosion group IIB	not with option Y____			
Cable entries											2	ANSI ½" NPT	–			
											4	ISO M20x1.5	not with Ex approval FF11 or FF12			

Model code	1.	2.	3.	4.	5.	6.	7.	8.	9.	10.	11.	12.	13.	14.	Description	Restriction	
Position																	
Communication type and I/O														JA	1 active current output HART, 1 passive pulse or status output	not with option CGC, C52	
														JB	2 active current outputs one with HART, 2 passive pulse or status outputs		
														JC	2 active current outputs one with HART, 1 passive pulse or status output, 1 voltage-free status input		
														JD	1 active current output HART, 2 passive pulse or status outputs, 1 passive status output		
														JE	1 active current output HART, 2 passive pulse or status outputs, 1 voltage-free status input		
														JF	1 active current output HART, 1 passive pulse or status output, 1 active pulse or status output with pull-up resistor, 1 voltage-free status input		
														JG	1 active current output HART, 1 passive pulse or status output, 1 active pulse or status output, 1 voltage-free status input		
														JH	1 active current output HART, 1 passive pulse or status output, 1 passive current output, 1 active current input	not with transmitter E, not with option C52	
														JJ	1 active current output HART, 2 passive pulse or status outputs, 1 active current input		
														JK	1 active current output HART, 1 passive pulse or status output, 1 voltage-free status input, 1 active current input		
														JL	1 active current output HART, 1 passive pulse or status output, 1 passive current output, 1 passive current input		
														JM	1 active current output HART, 2 passive pulse or status outputs, 1 passive current input		
														JN	1 active current output HART, 1 passive pulse or status output, 1 voltage-free status input, 1 passive current input		
														JP	2 passive current outputs one with HART, 1 passive pulse or status output		
														JQ	2 passive current outputs one with HART, 2 passive pulse or status outputs	not with Ex approval NN00 not with option CGC, C52, MC2, MC3	
														JR	2 passive current outputs one with HART, 1 passive NAMUR pulse or status output		
														JS	2 passive current outputs one with HART, 2 passive NAMUR pulse or status outputs		
														M0	Modbus output, 1 passive pulse or status output	not with option CGC, PS	
														M2	Modbus output, 1 passive pulse or status output, 1 active current input	not with transmitter E, not with option PS	
														M3	Modbus output, 2 passive pulse or status outputs	not with option CGC , PS	
														M4	Modbus output, 1 passive pulse or status output, 1 active pulse or status output		
														M5	Modbus output, 1 passive pulse or status output, 1 active pulse or status output with pull-up resistor		
														M6	Modbus output, 1 passive pulse or status output, 1 active current output		
														M7	Modbus output, 1 passive pulse or status output, 1 passive current input		
	Display														0	No display	not with transmitter U
															1	With display	-



### 9.4 Overview MS code Prime 80

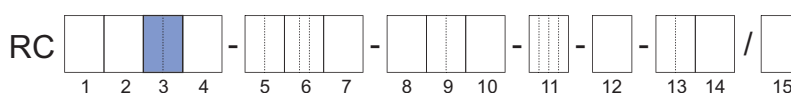

Model code Position	1.	2.	3.	4.	5.	6.	7.	8.	9.	10.	11.	12.	13.	14.	Description	Restriction
Transmitter	E														Essential (base function)	not with accuracy E3, E2, D7, D3, D2, C7, C3, C2, 50 not with communication type and I/O JH, JJ, JK, JL, JM, JN, M2, M7
	U														Ultimate (high function)	not with accuracy E7, 70 not with display 0
Sensor	P														Prime	–
Meter size	80														Nominal mass flow : 51 t/h (1900 lb/min) Maximum mass flow: 76 t/h (2800 lb/min)	not with option EPT
Material wetted parts	S														Stainless steel 1.4404/316L	–
Process connection size	40														DN40, 1½"	–
	50														DN50, 2"	
	65														DN65, 2½"	
	80														DN80, 3"	
Process connection type	BA1														ASME flange class 150, suitable for ASME B16.5	see table on page [ 40]
	BA2														ASME flange class 300, suitable for ASME B16.5	
	BA4														ASME flange class 600, suitable for ASME B16.5	
	CA4														ASME flange class 600, suitable for ASME B16.5, ring joint	
	BD4														EN flange PN 40, suitable for EN 1092-1 form B1	not with option WPA, RTA, PTA, P20
	ED4														EN flange PN 40, suitable for EN 1092-1 form E, spigot	
	FD4														EN flange PN 40, suitable for EN 1092-1 form F, recess	
	GD4														EN flange PN 40, suitable for EN 1092-1 form D, safety grooves	
	BD6														EN flange PN 100, suitable for EN 1092-1 form B1	
	ED6														EN flange PN 100, suitable for EN 1092-1 form E, spigot	
	FD6														EN flange PN 100, suitable for EN 1092-1 form F, recess	
	GD6														EN flange PN 100, suitable for EN 1092-1 form D, safety grooves	
	BJ1														JIS flange 10K, JIS B 2220	not with option WPA, RTA, PTA, P20
	BJ2														JIS flange 20K, JIS B 2220	see table on page [ 43]
BP1														JPI flange class 150	not with option WPA, RTA, PTA, P20	
BP2														JPI flange class 300	see table on page [ 43]	
BP4														JPI flange class 600	see table on page [ 43]	
Sensor housing material	0														Stainless steel 1.4301/304, 1.4404/316L	–
Medium temperature range	0														Standard, integral type: -50 – 150 °C (-58 – 302 °F), remote type: -70 – 200 °C (-94 – 392 °F)	–
Mass flow and density accuracy	E7														Liquid: 0.2 % maximum mass flow deviation $D_{flat}$ , 4 g/l density deviation	not with transmitter U
	E3														Liquid: 0.2 % maximum mass flow deviation $D_{flat}$ , 1 g/l density deviation	not with transmitter E
	E2														Liquid: 0.2 % maximum mass flow deviation $D_{flat}$ , 0.5 g/l density deviation	
	D7														Liquid: 0.15 % maximum mass flow deviation $D_{flat}$ , 4 g/l density deviation	
	D3														Liquid: 0.15 % maximum mass flow deviation $D_{flat}$ , 1 g/l density deviation	
	D2														Liquid: 0.15 % maximum mass flow deviation $D_{flat}$ , 0.5 g/l density deviation	
	C7														Liquid: 0.1 % maximum mass flow deviation $D_{flat}$ , 4 g/l density deviation	
	C3														Liquid: 0.1 % maximum mass flow deviation $D_{flat}$ , 1 g/l density deviation	
	C2														Liquid: 0.1 % maximum mass flow deviation $D_{flat}$ , 0.5 g/l density deviation	
	70														Gas: 0.75 % maximum mass flow deviation $D_{flat}$	not with transmitter U not with option CST, AC..., C52
50														Gas: 0.5 % maximum mass flow deviation $D_{flat}$	not with transmitter E not with option CST, AC..., C52	

Model code	1.	2.	3.	4.	5.	6.	7.	8.	9.	10.	11.	12.	13.	14.	Description	Restriction	
Position																	
Design and housing											0					Integral type with "urethane-cured polyester powder coating" coated aluminum transmitter housing	not with option L____, MC_, Y____
											2					Integral type with "corrosion protection coating" coated aluminum transmitter housing	
											A					Remote type with "urethane-cured polyester powder coating" coated aluminum transmitter housing and standard neck sensor	not with option RB
											E					Remote type with "corrosion protection coating" coated aluminum transmitter housing and standard neck sensor	
											J					Remote type stainless steel transmitter and standard neck sensor	not with Ex approval KF21, SF21, UF21, NF21, QF21 not with option RB
Ex approval											NN00					None	not with communication type and I/O JP, JQ, JR, JS not with option EPT
											KF21					ATEX, explosion group IIC and IIIC	not with design and housing J
											KF22					ATEX, explosion group IIB and IIIC	–
											SF21					IECEX, explosion group IIC and IIIC	not with design and housing J
											SF22					IECEX, explosion group IIB and IIIC	–
											FF11					FM, groups A, B, C, D, E, F, G	not with cable entries 4
											FF12					FM, groups C, D, E, F, G	not with option Y____
											UF21					INMETRO, explosion group IIC and IIIC	not with Design and housing J not with option Y____
											UF22					INMETRO, explosion group IIB and IIIC	not with option Y____
											NF21					NEPSI, explosion group IIC and IIIC	not with Design and housing J not with option Y____ only with option CN
											NF22					NEPSI, explosion group IIB and IIIC	not with option Y____ only with option CN
											QF21					PESO, explosion group IIC	not with design and housing J not with option: Y____
											QF22					PESO, explosion group IIB	not with option Y____
	Cable entries											2					ANSI ½" NPT
										4					ISO M20x1.5	not with Ex approval FF11 or FF12	

Model code Position	1.	2.	3.	4.	5.	6.	7.	8.	9.	10.	11.	12.	13.	14.	Description	Restriction	
Communication type and I/O													JA		1 active current output HART, 1 passive pulse or status output	not with option CGC, C52	
													JB		2 active current outputs one with HART, 2 passive pulse or status outputs		
													JC		2 active current outputs one with HART, 1 passive pulse or status output, 1 voltage-free status input		
													JD		1 active current output HART, 2 passive pulse or status outputs, 1 passive status output		
													JE		1 active current output HART, 2 passive pulse or status outputs, 1 voltage-free status input		
													JF		1 active current output HART, 1 passive pulse or status output, 1 active pulse or status output with pull-up resistor, 1 voltage-free status input		
													JG		1 active current output HART, 1 passive pulse or status output, 1 active pulse or status output, 1 voltage-free status input		
														JH		1 active current output HART, 1 passive pulse or status output, 1 passive current output, 1 active current input	not with transmitter E, not with option C52
														JJ		1 active current output HART, 2 passive pulse or status outputs, 1 active current input	
														JK		1 active current output HART, 1 passive pulse or status output, 1 voltage-free status input, 1 active current input	
														JL		1 active current output HART, 1 passive pulse or status output, 1 passive current output, 1 passive current input	
														JM		1 active current output HART, 2 passive pulse or status outputs, 1 passive current input	
														JN		1 active current output HART, 1 passive pulse or status output, 1 voltage-free status input, 1 passive current input	
														JP		2 passive current outputs one with HART, 1 passive pulse or status output	
																2 passive current outputs one with HART, 2 passive pulse or status outputs	not with Ex approval NN00 not with option CGC, C52, MC2, MC3
														JR		2 passive current outputs one with HART, 1 passive NAMUR pulse or status output	
														JS		2 passive current outputs one with HART, 2 passive NAMUR pulse or status outputs	
														M0		Modbus output, 1 passive pulse or status output	not with option CGC, PS
														M2		Modbus output, 1 passive pulse or status output, 1 active current input	not with transmitter E, not with option PS
														M3		Modbus output, 2 passive pulse or status outputs	not with option CGC , PS
														M4		Modbus output, 1 passive pulse or status output, 1 active pulse or status output	
														M5		Modbus output, 1 passive pulse or status output, 1 active pulse or status output with pull-up resistor	
														M6		Modbus output, 1 passive pulse or status output, 1 active current output	
														M7		Modbus output, 1 passive pulse or status output, 1 passive current input	not with transmitter E, not with option PS
	Display													0		No display	not with transmitter U
														1		With display	–

9.5 Overview options

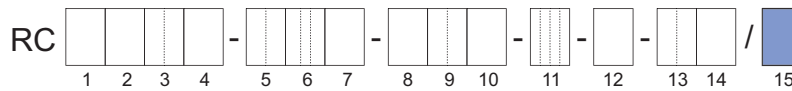

Option	Option code	Description	Restriction
Additional nameplate information	BG	Nameplate with customer-specific identification	–
Presetting of customer parameters	PS	Presetting according to customer parameters	not with communication type and I/O M_
Country-specific delivery	PJ	Delivery to Japan	–
	CN	Delivery to China	–
Concentration and petroleum measurement	AC0	Advanced concentration measurement, customer settings	not with transmitter type E not with mass flow and density accuracy 70, 50
	AC1	Advanced concentration measurement, one default data set	
	AC2	Advanced concentration measurement, two default data sets	
	AC3	Advanced concentration measurement, three default data sets	
	AC4	Advanced concentration measurement, four default data sets	
	CST	Standard concentration measurement	
Mass flow calibration	K2	Customer-specific 5-point mass flow calibration with factory calibration certificate (mass flow or volume flow of water). A table listing the desired calibration points must be supplied with the order.	–
	K5	Customer-specific 10-point mass flow calibration with DAkkS calibration certificate (mass flow or volume flow of water). A table listing the desired calibration points must be supplied with the order.	
Accordance with terms of order	P2	Declaration of compliance with the order 2.1 according to EN 10204	not with option P10, P11, P12, P13
	P3	Quality Inspection Certificate (Inspection Certificate 3.1 according to EN 10204)	
Material certificates	P6	Certificate of Marking Transfer and Raw Material Certificates (Inspection Certificate 3.1 according to EN 10204)	not with option P10, P11, P12, P13
Pressure testing	P8	Hydrostatic Pressure Test Certificate (Inspection Certificate 3.1 according to EN 10204)	not with option P10, P12, P13, P14
Surfaces free of oil and grease	H1	Degreasing of wetted surfaces according to ASTM G93-03 (Level C), including test report	–

Option	Option code	Description	Restriction
Welding certificates	WP	WPS according to DIN EN ISO 15609-1	not with option P13, P14, P15, P16, P20
		WPQR according to DIN EN ISO 15614-1	
		WQC according to DIN EN 287-1 or DIN EN ISO 6906-4	
	WPA	Welding procedures and Certificate according to ASME IX	not with option P12, P13, P14, P20 only with process connection type BA_ or CA_
Calibration certificate	L2	The certificate confirms that the delivered instrument has undergone a calibration traceable to national standards, including a list of working standards used for calibration. Language: English/Japanese	-
	L3	The certificate confirms that the delivered instrument has undergone a calibration traceable to national standards, including a list of primary standards to which the delivered product is traceable. Language: English/Japanese	
	L4	The certificate confirms that the delivered instrument has undergone a calibration traceable to national standards and that the calibration system of Rota Yokogawa is traceable to national standards. Language: English/Japanese	
X-ray inspection of flange weld seam	RT	X-ray inspection of flange weld seam according to DIN EN ISO 17636-1/B Evaluation according to AD 2000 HP 5/3 and DIN EN ISO 5817/C, including certificate	not with option P15, P16, P20
	RTA	X-ray test according to ASME V	not with option P12, P13, P14, P20 only with process connection type BA_ or CA_
Dye penetration test of weld seams	PT	Dye penetration test of process connection weld seams according to DIN EN ISO 3452-1, including certificate	not with option P12, P13, P15, P16, P20
	PTA	Dye Penetrant test of flange welding according to ASME V	not with option P12, P13, P14, P20 only with process connection type BA_ or CA_
Transmitter housing rotated 180°	RB	Alignment of transmitter housing rotated 180°	not with design and housing A, E, J
Expanded process temperature (Ex)	EPT	Expanded range of process and ambient temperatures for temperature classes T6, T5, T4 and T3 of hazardous area	not with meter size 80 not with Ex approval NN00
Measurement of heat quantity	CGC	Measurement of the total transported energy content of a fuel in connection with a sensor for determining the fuel's calorific value (e.g., a gas chromatograph, not included in scope of delivery)	not with transmitter type E only with communication type and I/O JH, JJ, JK, JL, JM, JN, M2, M7

Option	Option code	Description	Restriction
Sensor cable type and length	L000	Separate order for standard sensor cable	not with design and housing 0, 2 not with option MC_
	L005	5 meter (16.4 ft) remote sensor cable terminated std. gray / Ex blue	
	L010	10 meter (32.8 ft) remote sensor cable terminated std. gray / Ex blue	
	L015	15 meter (49.2 ft) remote sensor cable terminated std. gray / Ex blue	
	L020	20 meter (65.6 ft) remote sensor cable terminated std. gray / Ex blue	
	L030	30 meter (98.4 ft) remote sensor cable terminated std. gray / Ex blue	
	Y000	Separate ordered remote fire retardant sensor cable	not with design and housing 0, 2; not with Ex approval FF11, FF12, UF21,UF22, NF21, NF22, QF21, QF22
	Y005	5 meter (16.4 ft) remote fire retardant sensor cable not terminated	not with design and housing 0, 2; not with Ex approval FF11, FF12, UF21,UF22, NF21, NF22, QF21, QF22
	Y010	10 meter (32.8 ft) remote fire retardant sensor cable not terminated	not with design and housing 0, 2; not with Ex approval FF11, FF12, UF21,UF22, NF21, NF22, QF21, QF22
	Y015	15 meter (49.2 ft) remote fire retardant sensor cable not terminated	not with design and housing 0, 2; not with Ex approval FF11, FF12, UF21,UF22, NF21, NF22, QF21, QF22
	Y020	20 meter (65.6 ft) remote fire retardant sensor cable not terminated	not with design and housing 0, 2; not with Ex approval FF11, FF12, UF21,UF22, NF21, NF22, QF21, QF22
	Y030	30 meter (98.4 ft) remote fire retardant sensor cable not terminated	not with design and housing 0, 2; not with Ex approval FF11, FF12, UF21,UF22, NF21, NF22, QF21, QF22

Option	Option code	Description	Restriction
Marine Approval	MC2	Marine approval according to DNV GL piping class 2	not with design and housing 0, 2, communication type and I/O JP, JQ, JR, JS
	MC3	Marine approval according to DNV GL piping class 3	only with option Y_... in case of thermal oil applications option RT or RTA is mandatory
Combined certificate	P10	Combination of: <ul style="list-style-type: none"> <li>▪ P3: Quality Inspection Certificate</li> <li>▪ P6: Certificate of Marking Transfer and Raw Material Certificates</li> <li>▪ P8: Hydrostatic Pressure Test Certificate</li> </ul>	not with option P3, P6, P8
	P11	Combination of: <ul style="list-style-type: none"> <li>▪ P3: Quality Inspection Certificate</li> <li>▪ P6: Certificate of Marking Transfer and Raw Material Certificates</li> <li>▪ PM: Positive Material Identification of wetted parts</li> </ul>	not with option P3, P6, PM
	P12	Combination of: <ul style="list-style-type: none"> <li>▪ P3: Quality Inspection Certificate</li> <li>▪ P6: Certificate of Marking Transfer and Raw Material Certificates</li> <li>▪ PT: Dye penetration test according to DIN EN ISO 3452-1</li> <li>▪ P8: Hydrostatic Pressure Test Certificate</li> </ul>	not with option P3, P6, P8, P15, P16, WPA, RTA, PT, PTA
	P13	Combination of: <ul style="list-style-type: none"> <li>▪ P3: Quality Inspection Certificate</li> <li>▪ P6: Certificate of Marking Transfer and Raw Material Certificates</li> <li>▪ PT: Dye penetration test according to DIN EN ISO 3452-1</li> <li>▪ PM: Positive Material Identification of wetted parts</li> <li>▪ P8: Hydrostatic Pressure Test Certificate</li> <li>▪ WP: Welding certificates</li> </ul>	not with option P3, P6, P8, P15, P16, WP, WPA, RTA, PT, PTA, PM
	P14	Combination of: <ul style="list-style-type: none"> <li>▪ PM: Positive Material Identification of wetted parts</li> <li>▪ P8: Hydrostatic Pressure Test Certificate</li> <li>▪ WP: Welding certificates</li> </ul>	not with option P8, P15, P16, PM, WP, WPA, RTA, PTA
	P20	Combination of: <ul style="list-style-type: none"> <li>▪ PTA: Dye Penetrant test of flange welding according to ASME V</li> <li>▪ WPA: Welding procedures and Certificates according to ASME IX</li> <li>▪ RTA: X-ray test according to ASME V</li> </ul>	not with option WP, WPA, RT, RTA, PT, PTA only with process connection type BA_ or CA4
Positive Material Identification of wetted parts	PM	Positive Material Identification of wetted parts, including certificate (Inspection Certificate 3.1 according to EN 10204)	not with option P11, P13, P14

Option	Option code	Description	Restriction
Tube health check	TC	Tube health check	–
ASME B31.3 compliance	P15	ASME B31.3 compliance NORMAL FLUID SERVICE	not with option WP, RT, PT, P12, P13, P14 only with process connection type BA_ or CA_
	P16	ASME B31.3 compliance Category M FLUID SERVICE	not with option WP, RT, PT, P12, P13, P14 only with process connection type BA_ or CA_ only with option RTA



### 9.6 MS code

The MS code of the Rotamass TI is explained below.

Items 1 through 14 are mandatory entries and must be specified at the time of ordering.

Device options (item 15) can be selected and specified individually by separating them with slashes.

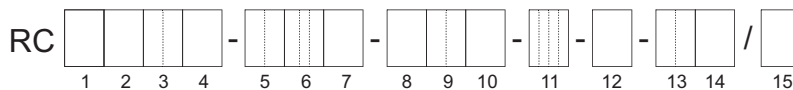

1. Transmitter
2. Sensor
3. Meter size
4. Material wetted parts
5. Process connection size
6. Process connection type
7. Sensor housing material
8. Medium temperature range
9. Mass flow and density accuracy
10. Design and housing
11. Ex approval
12. Cable entries
13. Communication type and I/O
14. Display
15. Options

#### 9.6.1 Transmitter

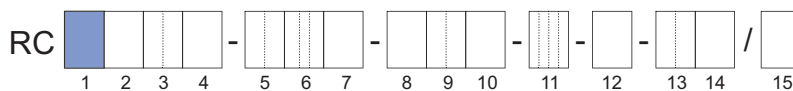

MS code	Transmitter
Position 1	
E	Essential
U	Ultimate

#### 9.6.2 Sensor

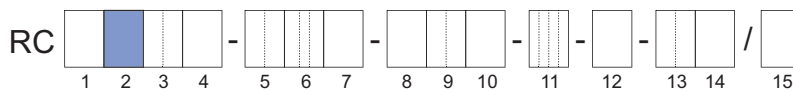

MS code	Sensor
Position 2	
P	Prime

9.6.3 Meter size

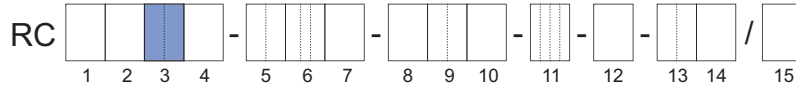

MS code Position 3	Meter size	Nominal mass flow in t/h (lb/min)	Maximum mass flow in t/h (lb/min)
25	25	1.6 (59)	2.3 (85)
40	40	4.7 (170)	7 (260)
50	50	20 (730)	29 (1100)
80	80	51 (1900)	76 (2800)

9.6.4 Material wetted parts

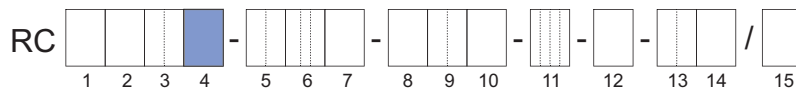

MS code Position 4	Material wetted parts
S	Stainless steel 1.4404/316L

9.6.5 Process connection size

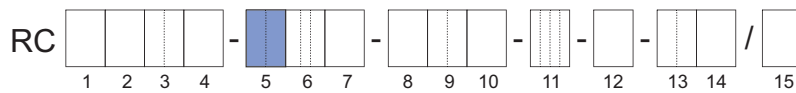

MS code Position 5	Process connection size
08	3/8"
15	DN15, 1/2"
20	DN20, 3/4"
25	DN25, 1"
40	DN40, 1 1/2"
50	DN50, 2"
65	DN65, 2 1/2"
80	DN80, 3"



Available sizes depend on the actual process connection, see also chapter *Process connections, dimensions and weights of sensor* [▶ 39].

### 9.6.6 Process connection type

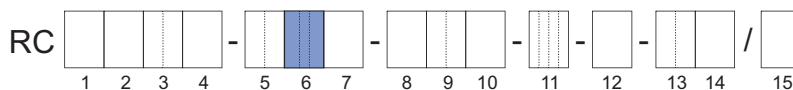

MS code Position 6	Type	Process connections
BA1	Flanges suitable for ASME B16.5	ASME flange class 150
BA2		ASME flange class 300
BA4		ASME flange class 600
CA4		ASME flange class 600, ring joint
BD4	Flange suitable for EN 1092-1	EN flange PN40, profile B1
ED4		EN flange PN40, profile E, with spigot
FD4		EN flange PN40, profile F, with recess
GD4		EN flange PN40, profile D, with safety groove
BD6		EN flange PN100, profile B1
ED6		EN flange PN100, profile E, with spigot
FD6		EN flange PN100, profile F, with recess
GD6		EN flange PN100, profile D, with safety groove
BJ1	Flange suitable for JIS B 2220	JIS flange 10K
BJ2		JIS flange 20K
BP1	Flange suitable for JPI	JPI flange class 150
BP2		JPI flange class 300
BP4		JPI flange class 600
TG9	Process connections with internal thread	Process connection with internal thread G
TT9		Process connection with internal thread NPT

### 9.6.7 Sensor housing material

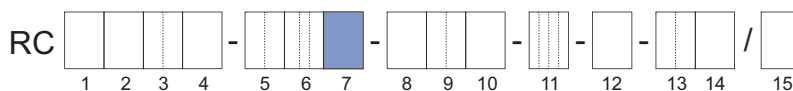

MS code Position 7	Housing material
0	Stainless steel 1.4301/304, 1.4404/316L

### 9.6.8 Medium temperature range

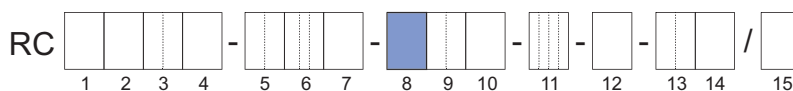

MS code Position 8	Temperature range	Medium temperature range
0	Standard	Integral type: -50 – 150 °C (-58 – 302 °F) Remote type: -70 – 200 °C (-94 – 392 °F)

For temperature range limits, see chapter *Medium temperature range* [▶ 26].

9.6.9 Mass flow and density accuracy

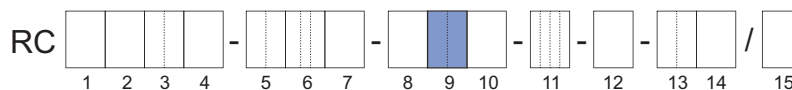

Medium	MS code Position 9	Maximum deviation		MS code Position 1
		Mass flow $D_{flat}$ in %	Density in g/l	
Liquid	E7	0.2	4	E
	E3	0.2	1	U
	E2	0.2	0.5	U
	D7	0.15	4	U
	D3	0.15	1	U
	D2	0.15	0.5	U
	C7	0.1	4	U
	C3	0.1	1	U
Gas	70	0.75	–	E
	50	0.5	–	U

Devices with value \_2 in MS code position 9 receive an additional density calibration with a corresponding certificate.

9.6.10 Design and housing

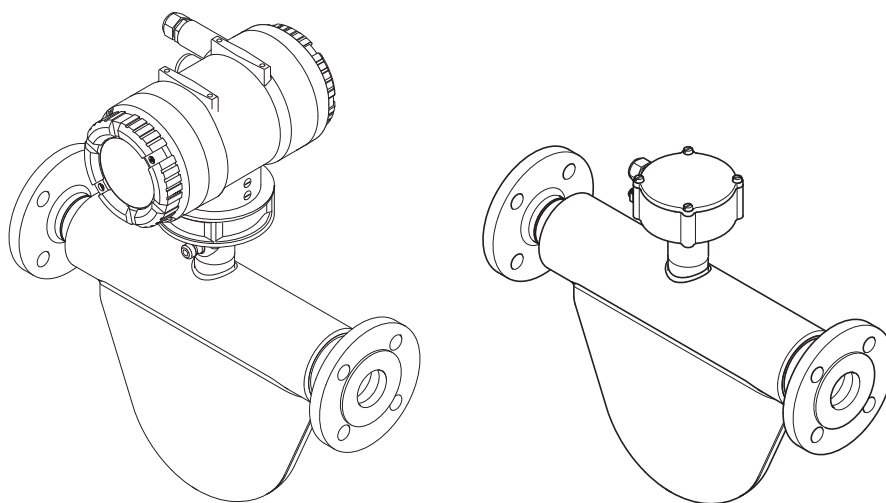
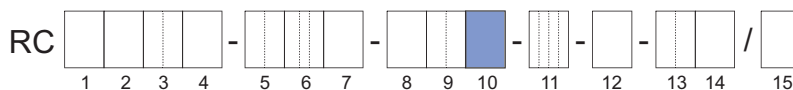

MS code Position 10	Design	Transmitter housing material	Transmitter housing coating	Sensor terminal box material
0	Integral type	Aluminum	Standard coating	-
2			Corrosion protection coating	
A	Remote type	Aluminum	Standard coating	Stainless steel
E			Corrosion protection coating	
J	Remote type	Stainless Steel	-	Stainless steel

The remote type requires a connecting cable to connect sensor and transmitter. It can be selected in various lengths as a device option, see *Connecting cable type and length* [▶ 89].

9.6.11 Ex approval

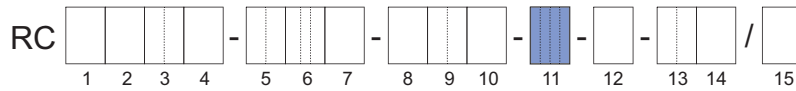

MS code Position 11	Ex approval
NN00	None
KF21	ATEX, explosion group IIC and IIIC
KF22	ATEX, explosion group IIB and IIIC
SF21	IECEx, explosion group IIC and IIIC
SF22	IECEx, explosion group IIB and IIIC
FF11	FM, group A, B, C, D, E, F, G
FF12	FM, group C, D, E, F, G
UF21	INMETRO, explosion group IIC and IIIC
UF22	INMETRO, explosion group IIB and IIIC
NF21	NEPSI, explosion group IIC and IIIC
NF22	NEPSI, explosion group IIB and IIIC
QF21	PESO, explosion group IIC
QF22	PESO, explosion group IIB

9.6.12 Cable entries

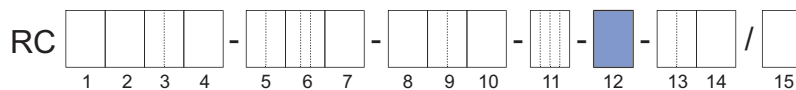

MS code Position 12	Cable entries
2	ANSI ½" NPT
4	ISO M20x1.5

9.6.13 Inputs and outputs

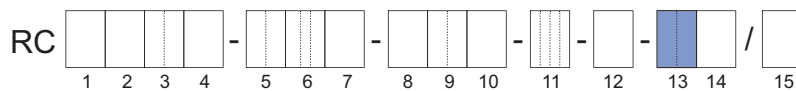

HART I/O

MS code Position 13	Connection terminal assignment				
	I/O1 +/-	I/O2 +/-	I/O3 +/-	I/O4 +/-	WP
JA	Iout1 Active	P/Sout1 Passive	–	–	Write-protect
JB	Iout1 Active	P/Sout1 Passive	P/Sout2 Passive	Iout2 Active	Write-protect
JC	Iout1 Active	P/Sout1 Passive	Sin	Iout2 Active	Write-protect
JD	Iout1 Active	P/Sout1 Passive	Sout Passive	P/Sout2 Passive	Write-protect
JE	Iout1 Active	P/Sout1 Passive	Sin	P/Sout2 Passive	Write-protect

MS code Position 13	Connection terminal assignment				
	I/O1 +/-	I/O2 +/-	I/O3 +/-	I/O4 +/-	WP
JF	lout1 Active	P/Sout1 Passive	Sin	P/Sout2 Active Internal pull-up resistor	Write-protect
JG	lout1 Active	P/Sout1 Passive	Sin	P/Sout2 Active	Write-protect
JH	lout1 Active	P/Sout1 Passive	lout2 Passive	lin Active	Write-protect
JJ	lout1 Active	P/Sout1 Passive	P/Sout2 Passive	lin Active	Write-protect
JK	lout1 Active	P/Sout1 Passive	Sin	lin Active	Write-protect
JL	lout1 Active	P/Sout1 Passive	lout2 Passive	lin Passive	Write-protect
JM	lout1 Active	P/Sout1 Passive	P/Sout2 Passive	lin Passive	Write-protect
JN	lout1 Active	P/Sout1 Passive	Sin	lin Passive	Write-protect

lout1 Active or passive current output with HART communication

lout2 Active or passive current output

lin Active or passive current input

P/Sout1 Passive pulse or status output

P/Sout2 Active or passive pulse or status output

Sin Status input

Sout Status output

#### HART I/O, intrinsically safe

MS code Position 13	Connection terminal assignment				
	I/O1 +/-	I/O2 +/-	I/O3 +/-	I/O4 +/-	WP
JP	lout1 Passive	P/Sout1 Passive	lout2 Passive	–	Write-protect
JQ	lout1 Passive	P/Sout1 Passive	lout2 Passive	P/Sout2 Passive	Write-protect
JR	lout1 Passive	P/Sout1 Passive NAMUR	lout2 Passive	–	Write-protect
JS	lout1 Passive	P/Sout1 Passive NAMUR	lout2 Passive	P/Sout2 Passive NAMUR	Write-protect

Intrinsically safe outputs are only available in combination with selecting Ex approval of the device, see chapter *Ex approval* [▶ 86].

Modbus I/O

MS code Position 13	Connection terminal assignment						
	I/O1 +/-	I/O2 +/-	I/O3 +	I/O3 -	I/O4 +	I/O4 -	WP
M0	–	P/Sout Passive	–	Modbus C	Modbus B	Modbus A	Write-protect
M2	lin Active	P/Sout Passive	–	Modbus C	Modbus B	Modbus A	Write-protect
M3	P/Sout Passive	P/Sout Passive	–	Modbus C	Modbus B	Modbus A	Write-protect
M4	P/Sout Active	P/Sout Passive	–	Modbus C	Modbus B	Modbus A	Write-protect
M5	P/Sout Active Internal pull-up resistor	P/Sout Passive	–	Modbus C	Modbus B	Modbus A	Write-protect
M6	lout Active	P/Sout Passive	–	Modbus C	Modbus B	Modbus A	Write-protect
M7	lin Passive	P/Sout Passive	–	Modbus C	Modbus B	Modbus A	Write-protect

lout Active current output, no HART  
 lin Active or passive current input  
 P/Sout Active or passive pulse or status output

9.6.14 Display

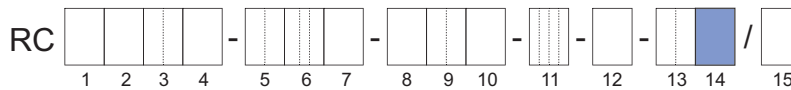

The display unit includes a slot for the microSD card.

MS code Position 14	Display
0	Without display
1	With display

Devices without a display are available for Essential transmitters only (value E in MS code position 1)



## 9.7 Options

Additional device options that can be combined may be selected; they are listed sequentially in MS code position 15. In this case, each device option is preceded by a slash.

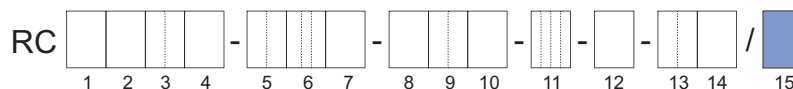

The following device options are possible:

- Connecting cable length, see chapter *Connecting cable type and length* [▶ 89]
- Customer-specific adaptation of the nameplate, see chapter *Additional nameplate information* [▶ 90]
- Flow meter presetting with customer parameters, see chapter *Presetting of customer parameters* [▶ 90]
- Concentration and petroleum measurement, see chapter *Concentration and petroleum measurement* [▶ 90]
- Certificates to be supplied, see chapter *Certificates* [▶ 92]
- Positive Material Identification of wetted parts, see chapter *Certificates* [▶ 93]
- Country -specific delivery *Country-specific delivery* [▶ 94]
- X-ray inspection of flange weld seam, see chapter *Certificates* [▶ 93]
- Tube health check, see chapter *Tube health check* [▶ 95]
- Transmitter housing rotated 180°, see chapter *Transmitter housing rotated 180°* [▶ 95]
- Measurement of heat quantity, see chapter *Measurement of heat quantity* [▶ 95]
- Marine type approval, see chapter *Marine Approval* [▶ 96]

### 9.7.1 Connecting cable type and length

When ordering the remote type, it is mandatory to always provide the desired connecting cable length.

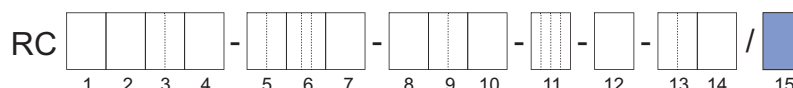

Options	Specification
L000	Separate order for standard sensor cable
L005	5 meter (16.4 ft) remote sensor cable terminated std. gray / Ex blue
L010	10 meter (32.8 ft) remote sensor cable terminated std. gray / Ex blue
L015	15 meter (49.2 ft) remote sensor cable terminated std. gray / Ex blue
L020	20 meter (65.6 ft) remote sensor cable terminated std. gray / Ex blue
L030	30 meter (98.4 ft) remote sensor cable terminated std. gray / Ex blue
Y000	Separate ordered remote fire retardant connecting cable
Y005	5 meter (16.4 ft) remote fire retardant connecting cable, not terminated
Y010	10 meter (32.8 ft) remote fire retardant connecting cable, not terminated
Y015	15 meter (49.2 ft) remote fire retardant connecting cable, not terminated
Y020	20 meter (65.6 ft) remote fire retardant connecting cable, not terminated
Y030	30 meter (98.4 ft) remote fire retardant connecting cable, not terminated

Fire retardant cable is mandatory for DNV GL type approval (Options MC2 and MC3). The minimum permissible ambient temperature for the two cable types differs (see chapter *Allowed ambient temperature for sensor* [▶ 31]). The cable type intended to be used needs to be indicated (with option L000 or Y000) even if connecting cable is ordered separately.

**9.7.2 Additional nameplate information**

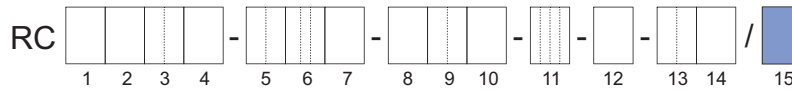

Options	Specification
BG	Nameplate with customer-specific identification

This marking (Tag No.) must be provided by the customer at the time the order is placed.

**9.7.3 Presetting of customer parameters**

Rotamass flow meters can be preconfigured with customer-specific data.

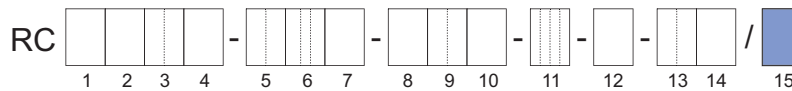

Options	Specification
PS	Presetting according to customer parameters.

**9.7.4 Concentration and petroleum measurement**

**Concentration measurement**

The standard concentration measurement (device option CST) can be used for concentration measurements of emulsions or suspensions when density of the media involved depends only on temperature.

The standard concentration measurement can also be used for many low-concentration solutions if there is only minor interaction between the liquids or if the miscibility is negligible. For questions regarding a specific application, contact the responsible Yokogawa sales organization. The appropriate density coefficients must be determined prior to using this option and input into the transmitter. To do so, the recommendation is to determine the necessary parameters from density data using DTM in the Yokogawa FieldMate program or the calculation tool included in the delivery.

The advanced concentration measurement is recommended for more complex applications, such as for liquids that interact.

**Petroleum measurement function NOC (option C52)**

“NOC” is an abbreviation of “Net Oil Computing” and it is an optional software function that is available only for Ultimate transmitter.

The NOC application can provide real-time measurements of water cut and includes “API” (American Petroleum Institute ) correction according to API MPMS Chapter 11.1 .

Oil types	Water types
Crude	Standard Mean Ocean Water
Refined Products: Fuel, Jet Fuel, Transition, Gasoline	UNESCO 1980
Lubricating	Fresh water density by API MPMS 11.4
Alpha 60	Produced water density by API MPMS 20.1 Appendix A.1
Custom	Brine water density by El-Dessouky, Ettouy (2002)
	Custom

In addition of Water Cut, the function can calculate: Net Oil Mass flow, Net Water Mass flow, Net Oil Volume flow, Net Water Volume flow and Net corrected Oil volume flow.

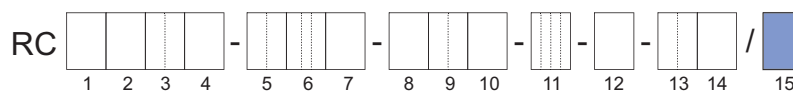

Options	Specification
CST	Standard concentration measurement
AC0	Advanced concentration measurement, customer settings
AC1	Advanced concentration measurement, one default data set
AC2	Advanced concentration measurement, two default data sets
AC3	Advanced concentration measurement, three default data sets
AC4	Advanced concentration measurement, four default data sets
C52	Total Net Oil computing TNO

These device options are not available in combination with gas measurement devices (model code position 9 with the values: 70 or 50).

Options with AC\_ and C52 are available only for Ultimate transmitters (value U in MS code position 1).

Sets must be selected for AC1 – AC4 options. Not applicable to AC0 option.

Following is a table that lists possible pre-configured concentrations. The desired data sets must be requested by the customer to the Yokogawa sales organization at the time the order is placed. The customer is responsible to ensure chemical compatibility of the material of the wetted parts with the measured chemicals. For strong acids or oxidizers which attack steel pipes a variant with wetted parts made of Ni alloy C-22/2.4602 is necessary.

Set	Medium A / B	Concentration range	Unit	Temperature range in °C	Density range in kg/l	Data source for density data
C01	Sugar / Water	0 – 85	°Bx	0 – 80	0.97 – 1.45	PTB... Messages 100 5/90: "The density of watery sucrose solutions after the introduction of the international temperature scale of 1990 (ITS1990)" Table 5
C02 <sup>1)</sup>	NaOH / Water	0 – 54	WT%	0 – 100	0.95 – 1.58	D'Ans-Lax, Handbook for chemists and physicists Vol.1, 3rd edition, 1967
C03	KOH / Water	1 – 55	WT%	54 – 100	1.01 – 1.58	D'Ans-Lax, Handbook for chemists and physicists Vol.1, 3rd edition, 1967
C04	NH <sub>4</sub> NO <sub>3</sub> / Water	1 – 50	WT%	0 – 80	0.97 – 1.24	Table of density data on request
C05	NH <sub>4</sub> NO <sub>3</sub> / Water	20 – 70	WT%	20 – 100	1.04 – 1.33	Table of density data on request
C06 <sup>1)</sup>	HCl / Water	22 – 34	WT%	20 – 60	1.08 – 1.17	D'Ans-Lax, Handbook for chemists and physicists Vol.1, 3rd edition, 1967
C07	HNO <sub>3</sub> / Water	50 – 67	WT%	10 – 60	1.26 – 1.40	Table of density data on request
C09 <sup>1)</sup>	H <sub>2</sub> O <sub>2</sub> / Water	30 – 75	WT%	4.5 – 43.5	1.00 – 1.20	Table of density data on request
C10 <sup>1)</sup>	Ethylene glycol / Water	10 – 50	WT%	-20 – 40	1.005 – 1.085	Table of density data on request
C11	Starch / Water	33 – 42.5	WT%	35 – 45	1.14 – 1.20	Table of density data on request
C12	Methanol / Water	35 – 60	WT%	0 – 40	0.89 – 0.96	Table of density data on request
C20	Alcohol / Water	55 – 100	VOL%	10 – 40	0.76 – 0.94	Table of density data on request
C21	Sugar / Water	40 – 80	°Bx	75 – 100	1.15 – 1.35	Table of density data on request
C30	Alcohol / Water	66 – 100	WT%	15 – 40	0.77 – 0.88	Standard Copersucar 1967
C37	Alcohol / Water	66 – 100	WT%	10 – 40	0.772 – 0.885	Brazilian Standard ABNT

<sup>1)</sup> We recommend using devices with wetted parts made of nickel alloy C22. Contact the Yokogawa sales organization about availability.

**9.7.5 Expanded process temperature (Ex)**

Options	Specification
EPT	Expanded range of process and ambient temperatures of temperature classes T6, T5, T4 and T3 for hazardous area

- For details of temperature specification of temperature classes compare temperature classification in *Temperature specification in hazardous areas* [▶ 32]

**9.7.6 Certificates**

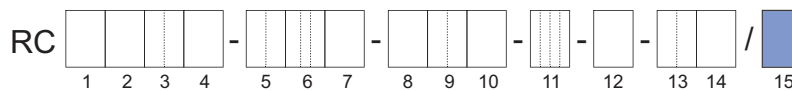

**Accordance with terms of order**

Options	Specification
P2	Declaration of compliance with the order 2.1 according to EN 10204
P3	Quality Inspection Certificate (Inspection Certificate 3.1 according to EN 10204)

**Material certificates**

Options	Specification
P6	Certificate of Marking Transfer and Raw Material Certificates (Inspection Certificate 3.1 according to EN 10204)

<b>Dye penetration test of weld seams</b>	Options	Specification
	PT	Dye penetrant test of process connection weld seams according to DIN EN ISO 3452-1, including certificate
	PTA	Dye penetrant test of flange welding according to ASME V
<b>Positive Material Identification of wetted parts</b>	Options	Specification
	PM	Positive Material Identification of wetted parts, including certificate (Inspection Certificate 3.1 according to EN 10204)
<b>Pressure testing</b>	Options	Specification
	P8	Hydrostatic Pressure Test Certificate (Inspection Certificate 3.1 according to EN 10204)
<b>Welding certificates</b>	Options	Specification
	WP	Welding certificates: <ul style="list-style-type: none"> <li>▪ WPS according to DIN EN ISO 15609-1</li> <li>▪ WPQR according to DIN EN ISO 15614-1</li> <li>▪ WQC according to DIN EN 287-1 or DIN EN ISO 6906-4</li> </ul>
	WPA	Welding procedures and Certificate according to ASME IX
<b>Mass flow calibration</b>	Only for the butt welding seam between the process connection and the flow divider. Water is used as medium for calibrating the Rotamass.	
	Options	Specification
	K2	Customer-specific 5-point mass flow calibration with factory calibration certificate (mass flow or volume flow of water). A table listing the desired calibration points must be supplied with the order.
K5	Customer-specific 10-point mass flow calibration with DAkkS calibration certificate (mass flow or volume flow of water). A table listing the desired calibration points must be supplied with the order.	
<b>Calibration certificates</b>	Options	Specification
	L2	The certificate confirms that the delivered instrument has undergone a calibration traceable to national standards, including a list of working standards used for calibration. Language: English/Japanese
	L3	The certificate confirms that the delivered instrument has undergone a calibration traceable to national standards, including a list of primary standards to which the delivered product is traceable. Language: English/Japanese
	L4	The certificate confirms that the delivered instrument has undergone a calibration traceable to national standards and that the calibration system of Rota Yokogawa is traceable to national standards. Language: English/Japanese
<b>Surfaces free of oil and grease</b>	Options	Specification
	H1	Degreasing of wetted surfaces according to ASTM G93-03 (Level C), including test report
<b>X-ray inspection of flange weld seam</b>	Options	Specification
	RT	X-ray inspection of flange weld seam according to DIN EN ISO 17636-1/B Evaluation according to AD 2000 HP 5/3 and DIN EN ISO 5817/C, including certificate
	RTA	X-ray test according to ASME V

**Combined certificates**

Options	Specification
P10	Combination of: <ul style="list-style-type: none"> <li>▪ P3: Quality Inspection Certificate</li> <li>▪ P6: Certificate of Marking Transfer and Raw Material Certificates</li> <li>▪ P8: Hydrostatic Pressure Test Certificate</li> </ul>
P11	Combination of: <ul style="list-style-type: none"> <li>▪ P3: Quality Inspection Certificate</li> <li>▪ P6: Certificate of Marking Transfer and Raw Material Certificates</li> <li>▪ PM: Positive Material Identification of wetted parts</li> </ul>
P12	Combination of: <ul style="list-style-type: none"> <li>▪ P3: Quality Inspection Certificate</li> <li>▪ P6: Certificate of Marking Transfer and Raw Material Certificates</li> <li>▪ PT: Dye penetration test according to DIN EN ISO 3452-1</li> <li>▪ P8: Hydrostatic Pressure Test Certificate</li> </ul>
P13	Combination of: <ul style="list-style-type: none"> <li>▪ P3: Quality Inspection Certificate</li> <li>▪ P6: Certificate of Marking Transfer and Raw Material Certificates</li> <li>▪ PT: Dye penetration test according to DIN EN ISO 3452-1</li> <li>▪ PM: Positive Material Identification of wetted parts</li> <li>▪ P8: Hydrostatic Pressure Test Certificate</li> <li>▪ WP: Welding certificates</li> </ul>
P14	Combination of: <ul style="list-style-type: none"> <li>▪ PM: Positive Material Identification of wetted parts</li> <li>▪ P8: Hydrostatic Pressure Test Certificate</li> <li>▪ WP: Welding certificates</li> </ul>
P20	Combination of: <ul style="list-style-type: none"> <li>▪ PTA: Dye Penetrant test of flange welding according to ASME V</li> <li>▪ WPA: Welding procedures and Certificates according to ASME IX</li> <li>▪ RTA: X-ray test according to ASME V</li> </ul>

**ASME B31.3 compliance**

Options	Specification
P15	ASME B31.3 compliance NORMAL FLUID SERVICE
P16	ASME B31.3 compliance Category M FLUID SERVICE

**9.7.7 Country-specific delivery**

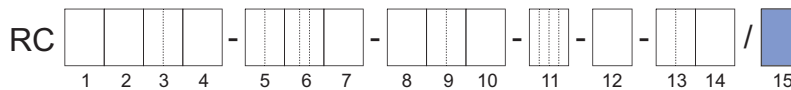

Options	Specification
PJ	Delivery to Japan
CN	Delivery to China

### 9.7.8 Tube health check

By way of the tube health check, the transmitter can determine whether the tube properties were altered due to corrosion or deposits and, whether they could impact accuracy as a result.

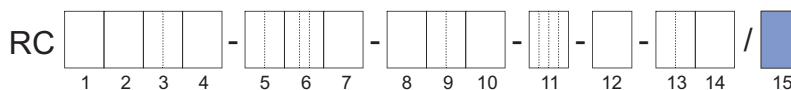

Options	Specification
TC	Tube health check

### 9.7.9 Transmitter housing rotated 180°

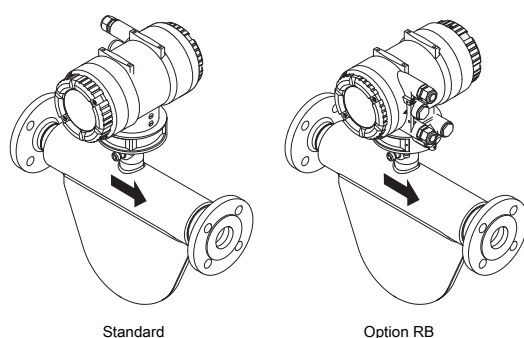
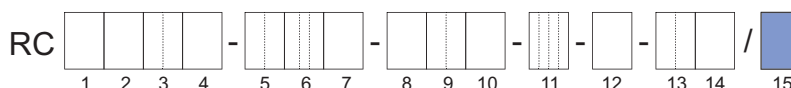

Options	Specification
RB	Alignment of transmitter housing rotated 180°

### 9.7.10 Measurement of heat quantity

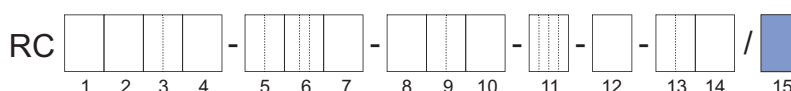

Options	Specification
CGC	<p>Measurement of the total transported energy content of a fuel in connection with a sensor for determining the fuel's calorific value (e.g., a gas chromatograph, not included in scope of delivery).</p> <p>This option is available only together with MS code position 13 JH to JN.</p>

The function allows to evaluate the total fuel calorific value of the measured fluid. The function can work with a constant value of the calorific value of the fluid, but to have a precise evaluation is suggested an additional device like a gas chromatograph not included in the supply. The external device that supplies the instantaneous calorific value is connected with the current input of the transmitter (MS code position 13: from JH to JN) Based on the mass flow, the Total Calorific Energy of the fluid is calculated as below:

$$\text{Total Calorific Energy} = \sum [(\text{Mass Flow rate})_i \times H_i \times \Delta t]$$

where  $H_i$  is the variable Calorific Value and  $\Delta t$  is the time interval between two measurements. Other formula based on Volume and Corrected Volume are included in the function and can be set using the display or the configuration PC software FieldMate.

**9.7.11 Marine Approval**

By ordering Options MC2 and MC3 the device will carry a type approval mark by DNV GL. Ordering of fire retardant cable (Y\_...) is mandatory with this option. In case of thermal oil applications option RT or RTA is mandatory. Please note that DNV GL has additional requirements regarding the process conditions as reproduced in the table below. The complete requirements can be found in the classification society's rules concerning the respective use case. Marine approval is not available for all device variants, for details see exclusions in *Overview options [ 76]*.

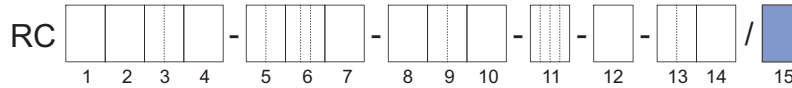

	Option			
	MC2		MC3	
Piping system for	Class II <sup>1)</sup>		Class III <sup>1)</sup>	
	p in bar	T <sub>pro</sub> in °C	p in bar	T <sub>pro</sub> in °C
Steam	≤ 16	≤ 300	≤ 7	≤ 170
Thermal oil	≤ 16	≤ 300	≤ 7	≤ 150
Fuel oil, lubricating oil, flammable oil	≤ 16	≤ 150	≤ 7	≤ 60
Other media <sup>2)</sup>	≤ 40	≤ 300	≤ 16	≤ 200

p : Design pressure

T<sub>pro</sub> : Design temperature

<sup>1)</sup> both specified conditions shall be met

<sup>2)</sup> Cargo oil pipes on oil carriers and open ended pipes (drain overflows, vents, boiler escape pipes etc.) independently of the pressure and temperature, are pertaining to class III.

Options	Specification
MC2	Marine approval according to DNV GL piping class 2
MC3	Marine approval according to DNV GL piping class 3

**9.7.12 Customer specific special product manufacture**

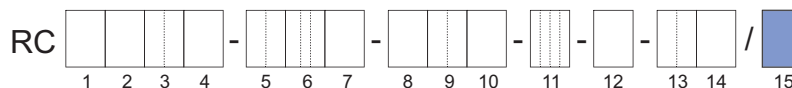

Options	Specification
Z	Deviations from the specifications in this document are possible.



## 9.8 Ordering Instructions

Specify the following information when ordering a product:

- Model code, suffix code, and option code
- Fluid name
- Language of the instruction manual:
  - English
  - French
  - German
  - Japanese
- Display language and language pack (Display only present for value 1 on position 14 of the MS code):
  - EN-Pack1 - English
  - DE-Pack1 - German
  - FR-Pack1 - French
  - PO-Pack1 - Portuguese
  - JA-Pack1 - Japanese
  - IT-Pack1 - Italian
  - EN-Pack2 - English
  - DE-Pack2 - German
  - RU-Pack2 - Russian
  - PL-Pack2 - Polish
  - KZ-Pack2 - Kazakh
  - EN-Pack3 - English
  - DE-Pack3 - German
  - FR-Pack3 - French
  - PO-Pack3 - Portuguese
  - IT-Pack3 - Italian
  - ES-Pack3 - Spanish
  - CN-Pack3 - Chinese
- Orientation of the display (Display only present for value 1 on position 14 of the MS code):

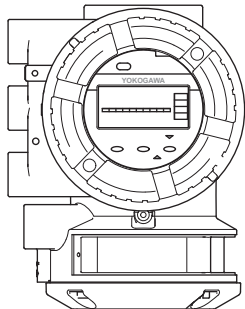
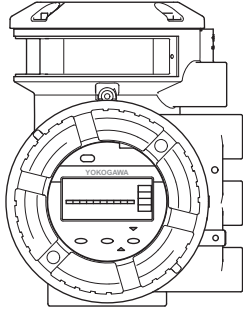
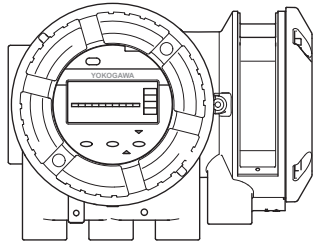
Orientation 1	Orientation 2	Orientation 3
Integral type (Horizontal installation - tubes down)	Integral type (Horizontal installation - tubes up) Remote type	Integral type (vertical installation)
		

- Tag No. to be engraved on the nameplate (option BG, up to 16 characters length)

- Software Tag No. (both short and long):
  - HART Tag No. (short): up to 8 characters length (Capital letters only)
  - HART Tag No. (long): up to 32 characters length
- Customer name for the certificates (option L2, L3, L4: up to 60 characters length)
- Advanced concentration type (option AC1 – AC4, see *Concentration and petroleum measurement [▶ 90]*):
  - C01 Sugar / Water 0 – 85 °Bx, 0 – 80 °C
  - C02 NaOH / Water 2 – 50 WT%, 0 – 100 °C
  - C03 KOH / Water 0 – 60 WT%, 54 – 100 °C
  - C04 NH<sub>4</sub>NO<sub>3</sub> / Water 1 – 50 WT%, 0 – 80 °C
  - C05 NH<sub>4</sub>NO<sub>3</sub> / Water 20 – 70 WT%, 20 – 100 °C
  - C06 HCl / Water 22 – 34 WT%, 20 – 40 °C
  - C07 HNO<sub>3</sub> / Water 50 – 67 WT%, 10 – 60 °C
  - C09 H<sub>2</sub>O<sub>2</sub> / Water 30 – 75 WT%, 4 – 44 °C
  - C10 Ethylene Glycol / Water 10 – 50WT%, -20 – 40 °C
  - C11 Amylum = starch / Water 33 – 43WT%, 35 – 45 °C
  - C12 Methanol / Water 35 – 60 WT%, 0 – 40 °C
  - C20 Alcohol / Water 55 – 100 VOL%, 10 – 40 °C
  - C21 Sugar / Water 40 – 80 °Bx, 75 – 100 °C
  - C30 Alcohol / Water 66 – 100 WT%, 15 – 40 °C
  - C37 Alcohol / Water 66 – 100 WT%, 10 – 40 °C



All rights reserved. Copyright © 2017-07-14

**YOKOGAWA ELECTRIC CORPORATION**

**Headquarters**

2-9-32, Nakacho, Musashino-shi,  
Tokyo, 180-8750 JAPAN  
Phone : 81-422-52-5555

**Branch Sales Offices**

Osaka, Nagoya, Hiroshima,  
Kurashiki, Fukuoka, Kitakyusyu

**YOKOGAWA CORPORATION OF AMERICA**

**Head Office**

12530 West Airport Blvd, Sugar Land,  
Texas 77478, USA  
Phone : 1-281-340-3800  
Fax : 1-281-340-3838

**Georgia Office**

2 Dart Road, Newnan, Georgia 30265, USA  
Phone : 1-800-888-6400/ 1-770-253-7000  
Fax : 1-770-254-0928

**YOKOGAWA AMERICA DO SUL LTDA.**

Praca Acapulco, 31 - Santo Amaro, São Paulo/SP,  
BRAZIL, CEP-04675-190  
Phone : 55-11-5681-2400  
Fax : 55-11-5681-4434

**YOKOGAWA EUROPE B. V.**

Euroweg 2, 3825 HD Amersfoort,  
THE NETHERLANDS  
Phone : 31-88-4641000  
Fax : 31-88-4641111

**YOKOGAWA ELECTRIC CIS LTD.**

Grokholskiy per 13 Building 2, 4th Floor 129090,  
Moscow, RUSSIA  
Phone : 7-495-737-7868  
Fax : 7-495-737-7869

**YOKOGAWA CHINA CO., LTD.**

3F Tower D Cartelo Crocodile Building,  
No.568 West Tianshan Road,  
Shanghai 200335, CHINA  
Phone : 86-21-62396262  
Fax : 86-21-62387866Z

**YOKOGAWA ELECTRIC KOREA CO., LTD.**

(Yokogawa B/D, Yangpyeong-dong 4-Ga),  
21, Seonyu-ro 45-gil, Yeongdeungpo-gu,  
Seoul, 150-866, KOREA  
Phone : 82-2-2628-6000  
Fax : 82-2-2628-6400

**YOKOGAWA ENGINEERING ASIA PTE. LTD.**

5 Bedok South Road, Singapore 469270,  
SINGAPORE  
Phone : 65-6241-9933  
Fax : 65-6241-2606

**YOKOGAWA INDIA LTD.**

Plot No.96, Electronic City Complex,  
Hosur Road, Bangalore - 560 100,  
INDIA  
Phone : 91-80-4158-6000  
Fax : 91-80-2852-1442

**YOKOGAWA AUSTRALIA PTY. LTD.**

Tower A, 112-118 Talavera Road,  
Macquarie Park NSW 2113,  
AUSTRALIA  
Phone : 61-2-8870-1100  
Fax : 61-2-8870-1111

**YOKOGAWA MIDDLE EAST & AFRICA B.S.C.(C)**

P. O. Box 10070, Manama, Building 577,  
Road 2516, Busaitteen 225, Muharraq,  
Kingdom of SAUDI ARABIA  
Phone : 973-17358100  
Fax : 973-17336100



**YOKOGAWA** ◆