

Introduction

The SKIDM, developed by METIS Africa, is a multiphase skid designed for accurate flow measurement for testing production oil wells. The SKIDM is the sole system able to measure and calculate water, oil and gas flows, instantaneously, without phase separation (method commonly used on platforms where the 3 phases are separated in tank separators in order to count quantity of each phase individually), and without radioactive source (other method much more expensive).

The SKIDM is composed of several metering lines (with Coriolis Rotamass RCx38 mass flowmeters), a bypass line for measuring BSW (with a Rotamass RCx34), an EJX530A pressure transmitter, and an HMI EW115 ATEX screen (recorder / computer) positioned on the front of an ATEX Exe box.

Depending on the production flow for liquid and gas and associated pressure and temperature, the SKIDM is designed to fit this flow in a certain number of lines composed each line by a Coriolis RCx38. When the SKIDM is aligned with the production line of a production well, the total fluid will enter the SKIDM and is divided between those Coriolis flow meters.

Operating Principle

The total fluid will flow through the metering lines equipped with Coriolis flowmeters in parallel and it will measure the mass flow, the density and the temperature of the mixture.

In the by-pass line, it will measure the liquid density, and this is called the watercut line.

The Rotamass RCx38 of the metering lines measures:

- The mass flow rate of the oil, water and gas mixture
- The density of the oil, water and gas mixture
- Temperature

The Rotamass RCx34 / BSW line measures:

- The mass flow rate of the liquid fraction taken
- The density of the liquid fraction taken
- Temperature
- The coil excitation power to confirm the absence of gas bubbles

The EJX530A measures:

- Pressure in the SKIDM

The EW115 computer, it will calculate the GVF, GOR, water cut, mass or volume flow of gas, water and oil.

The density of the RCx34 / BSW, in which a 100% liquid sample of water and oil flows, is used to calculate the percentage of water in the liquid, the BSW (or watercut). To do this, the densities of the water and the oil will have been previously entered in the EW115 computer. We then have the density of the liquid phase and the % BSW.

The density of the gas is also entered in the EW115 calculator, and with the pressure and temperature measurements, the density of the gas phase is calculated based on the Boyle -Mariotte's Law in combination with compressibility factor of Natural Gas, at flow conditions P and T.

For the density of oil, it is calculated as per the standard API MPMS 11.1 and for the density of water as per the standard API MPMS 20.1.



The Rotamass RCx38 are positioned on the main metering lines. There can be 1 to 10 metering lines, depending on the flow range to be measured. These Rotamass therefore measure the general flow and the density of the mixture. By using the density of the three-phase mixture with the densities of the known liquid and gas phase, we then obtain the GVF, or the % of the gas phase in the fluid, at flow conditions P and T.

The general flow multiplied by the GVF gives us the gas flow.

With the density references from oil and water at standard condition obtained by the sample analyses from wellsite laboratory they are then converted to densities at operating conditions and then with the density of the liquid measured by the small Coriolis on the watercut line the flow computer calculates the BSW.

The general flow rate multiplied by (1-GVF) gives us the flow of liquid (water + oil liquid flow rates). The BSW will then allow us to calculate the water and oil flows.

Applications

- Real time surface flow measurement of oil, water and gas for onshore and offshore application.
- Individual well testing, production monitoring, production allocation and reservoir monitoring.
- Detection of any problem with pump wells.
- Determine the eruptivity with gas and/or liquid.

Advantages and benefits

- Accurate and instantaneous 24/7 flow rates measurements
- Without phase separation
- Without gas venting/flaring
- Without radioactive source use
- Without maintenance
- Small footprint
- Water Cut from 0 to 100% / GVF from 0 to 100%
- Compact design allowing easy mobility, SKIDM with wheels and transportable on a trailer or pick-up truck
- Remote and unmanned operation
- High rangeability (turn down 1:20, 1:40, 1:60...)

GENERAL SPECIFICATIONS

Fluid to be measured

Multiphase mixture of crude oil, water and gas. All densities can be measured.

Measuring Flow Rates

Please Refer to the codification table and curves pages 14/15/16 and/or contact METIS Africa ventes@metisafrica.com

Equipment on the SKIDM

Flowmeters: Coriolis Rotamass TI Supreme/Intense RCx34, RCx36, RCx38 or RCx39 depending on application

BSW: Coriolis Rotamass TI Supreme/Intense RCx34

Pressure: EJX530A

Temperature: from Coriolis

Calculation and record: ESA EW115

Sample point

Optional fully automated valves

Accuracy

From GVF 0% to 99.0%

Liquid and Gas phases:

+/- 2 % reading + 1% Full Scale with 95% confidence

From GVF 99.0% to 100.0%

Liquid and Gas phases:

+/- 5 % reading + 2% Full Scale with 95% confidence

Watercut: <1% absolute

Suggested accuracy depends on process conditions, contact METIS Africa for more details

Repeatability

1% of reading (Liquid and Gas Flow rates)

Calibration

The SKIDM is factory calibrated on a multiphase flow rig. Lab conditions to be as close as possible to process conditions in terms of pressure, flow, BSW, GVF, temperature, viscosity and salinity.

Power Supply Voltage

24VDC or 230VAC, specified at order registration

Outputs

Modbus TCP

4 analog outputs 4-20mA (optional)

Communication

Modbus RTU as standard with the instruments of the SKIDM

Modbus TCP to communicate with PLC / DCS

NORMAL OPERATING CONDITION

(Optional features or approval codes may affect limits.)

Ambient Temperature Limits

-10 to 50°C with HMI ESA EW115

Process Temperature Limits

-40 to 120°C (-40 to 248°F)

Ambient Humidity Limits

0 to 100% RH

PHYSICAL SPECIFICATIONS

Non-wetted Parts Materials Housing

ATEX box, pressure transmitter housing, Coriolis transmitter housing: Aluminum Alloy with polyurethane corrosion-resistant coating.

Options available to get SS housing

Structure body

SS 304L

Other on request

Wetted parts

SS 316L (pipe, flanges, valves, flowmeters, watercut meter, pressure transmitter, manifolds)

Other on request

Electrical connection

ANSI ½ NPT F

ISO M20 x 1.5 F

Weight and dimensions

Depending on the application.

Contact ventes@metisafrica.com

Signal cables

- Between ATEX box and Coriolis flowmeters: 03IP09EGFA

- Between watercut meter and pressure transmitter: 01IP09EGFA

Hazardous area

IECEX, ATEX, FM (USA/Canada), NEPSI,

INMETRO, PESO, Taiwan Safety Label

Pressure limits

Up to 250 bar, depending on flange rating and application.

Contact ventes@metisafrica.com

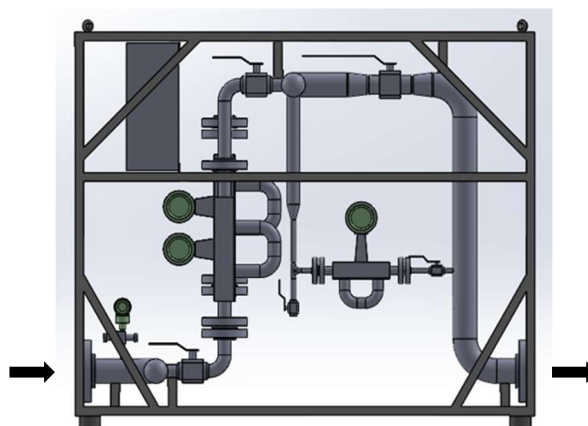

EXAMPLES OF DISPLAY WITH REAL DATA

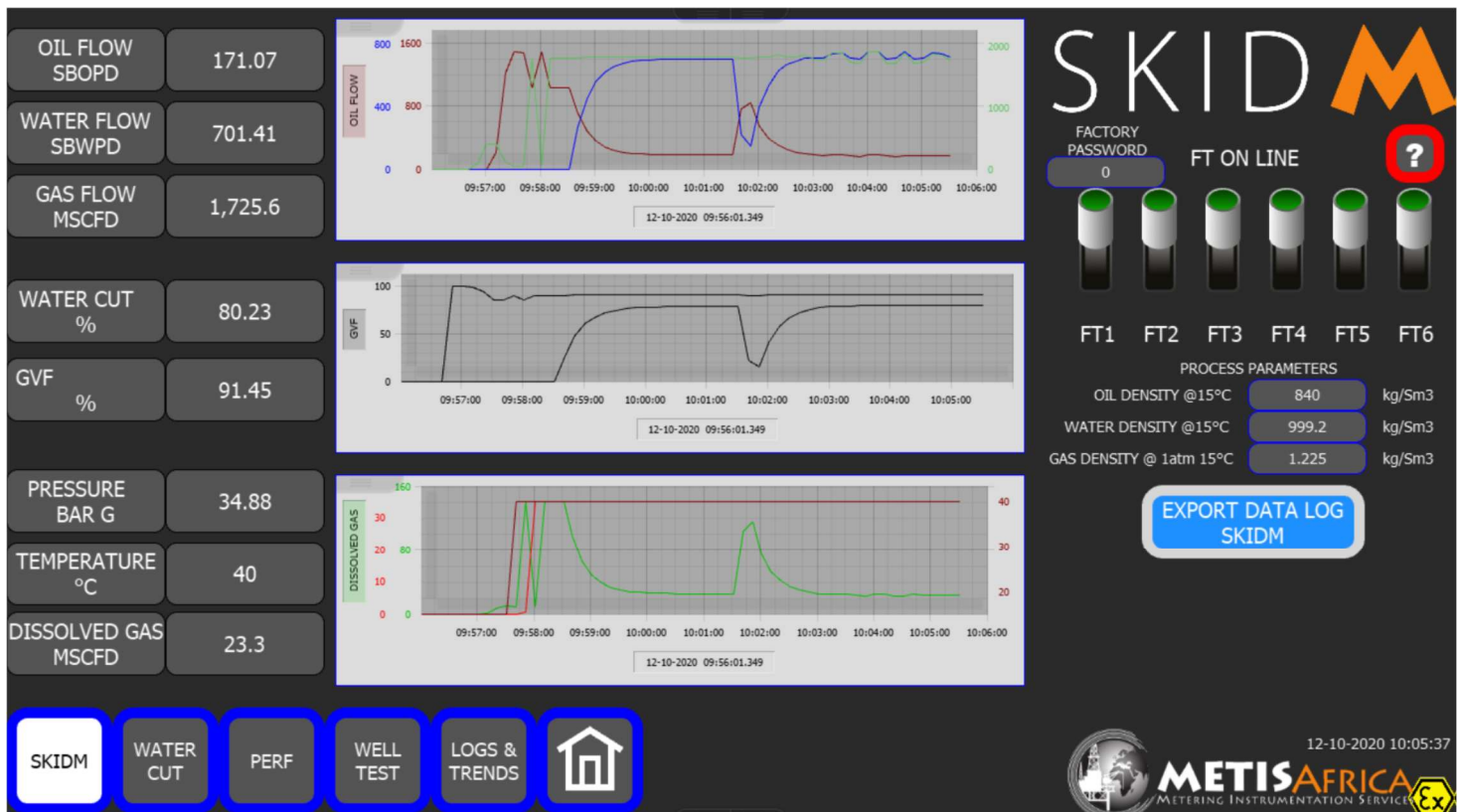
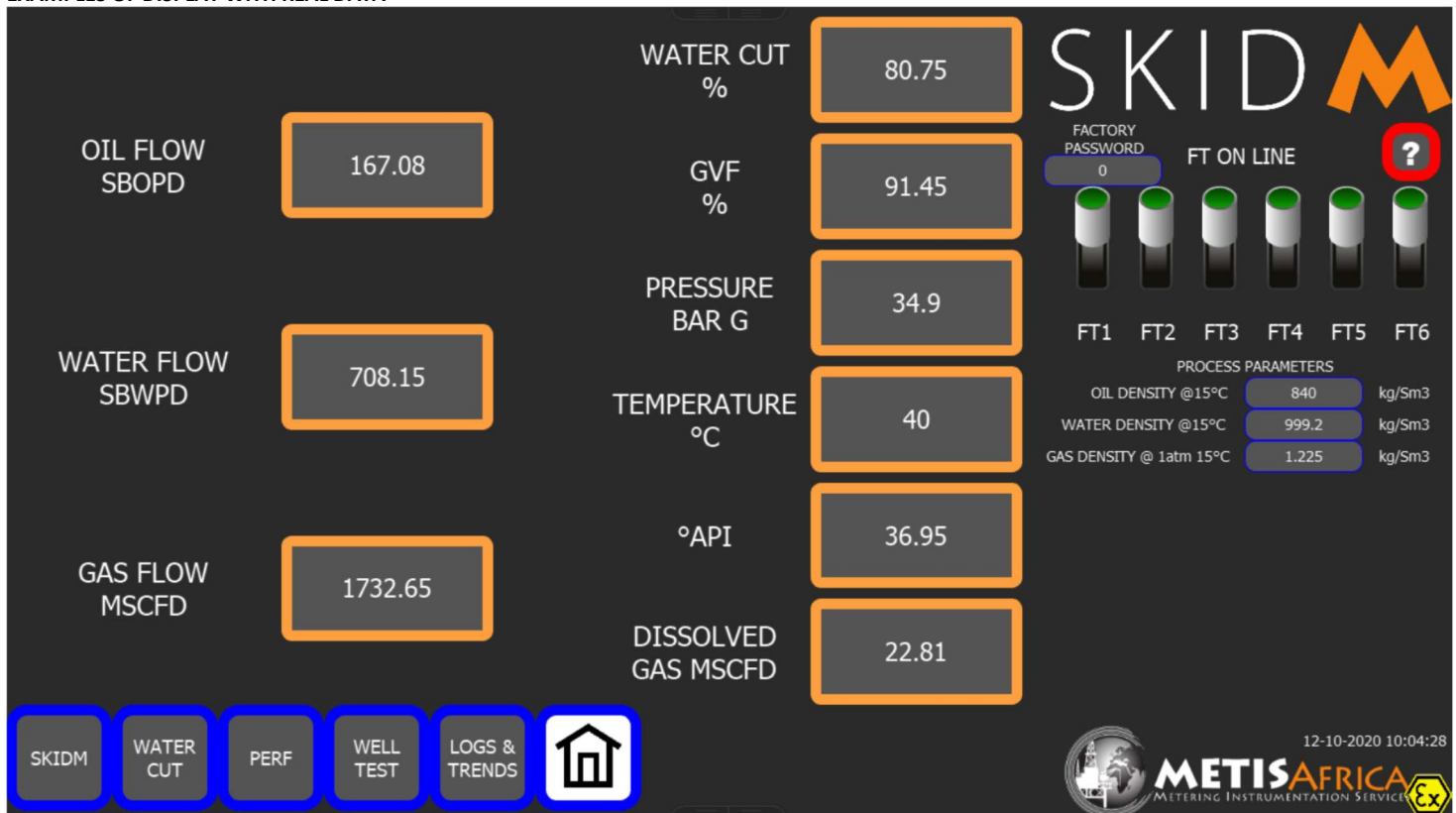

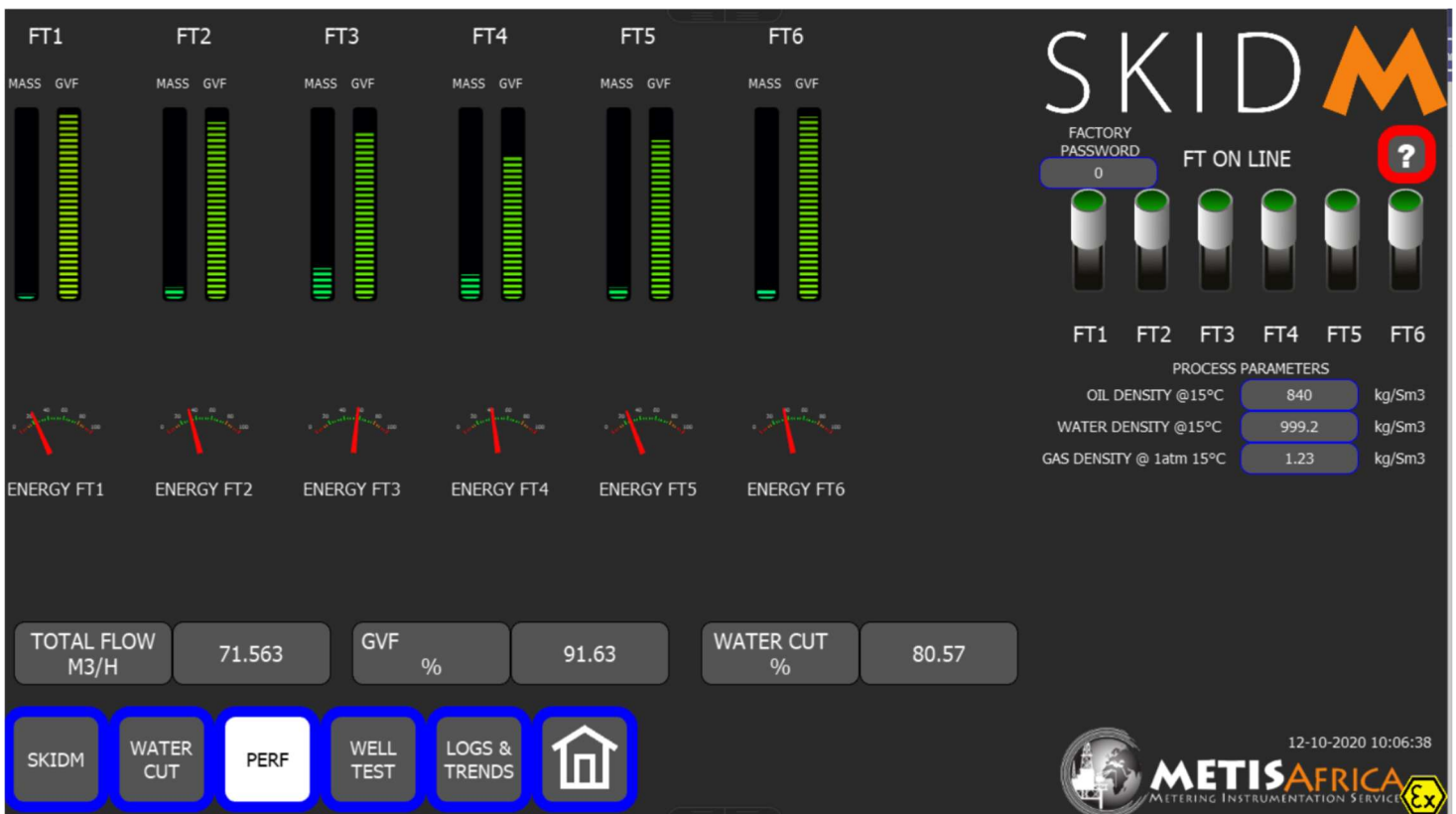
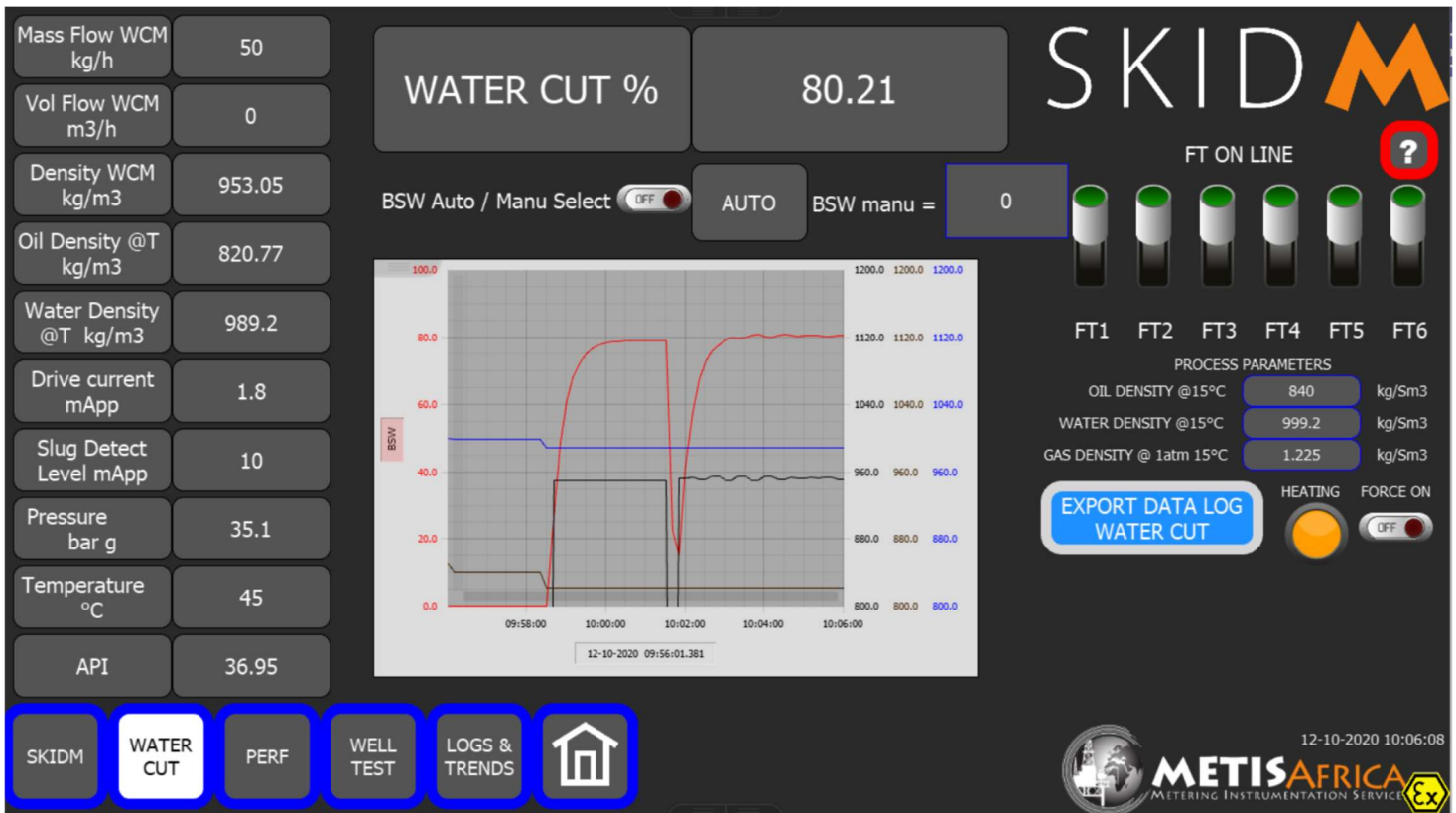



MODEL AND SUFFIX CODES

Model	Suffix codes	Description
SkidM	Multiphase Skid for fluid measurement
Number of lines	-1..... -2..... -3..... -4..... -5..... -6..... -7..... -8..... -9..... -10.....	1 line 2 lines 3 lines 4 lines 5 lines 6 lines 7 lines 8 lines 9 lines 10 lines
Model of Coriolis Flowmeters (x="Supreme" or "Intense")	-RCx34..... -RCx36..... -RCx38.....	Coriolis Rotamass TI RCx34 (Qnom 3 t/h / Qmax 5 t/h / GVFmax 100%) Coriolis Rotamass TI RCx36 (Qnom 10 t/h / Qmax 17 t/h / GVFmax 100%) Coriolis Rotamass TI RCx38 (Qnom 32 t/h / Qmax 50 t/h / GVFmax 100%)
Inlet / Outlet Flange Size and rating	-02A1..... -02A2..... -02A4..... -02A5..... -02A6..... -04A1..... -04A2..... -04A4..... -04A5..... -04A6..... -05A1..... -05A2..... -05A4..... -05A5..... -05A6..... -08A1..... -08A2..... -08A4..... -08A5..... -08A6..... -10A1..... -10A2..... -10A4..... -10A5..... -10A6..... -12A1..... -12A2..... -12A4..... -12A5..... -12A6..... -14A1..... -14A2..... -14A4..... -14A5..... -14A6..... -02D4..... -02D5..... -02D6..... -04D4..... -05D4..... -05D5..... -08D4..... -10D2..... -10D4..... -O.....	1" cl. 150 1" cl. 300 1" cl. 600 1" cl. 900 1" cl. 1500 1,5" cl. 150 1,5" cl. 300 1,5" cl. 600 1,5" cl. 900 1,5" cl. 1500 2" cl. 150 2" cl. 300 2" cl. 600 2" cl. 900 2" cl. 1500 3" cl. 150 3" cl. 300 3" cl. 600 3" cl. 900 3" cl. 1500 4" cl. 150 4" cl. 300 4" cl. 600 4" cl. 900 4" cl. 1500 5" cl. 150 5" cl. 300 5" cl. 600 5" cl. 900 5" cl. 1500 6" cl. 150 6" cl. 300 6" cl. 600 6" cl. 900 6" cl. 1500 DN25 PN10-40 DN25 PN63 DN25 PN100 DN40 PN10-40 DN50 PN10-40 DN50 PN63 DN80 PN10-40 DN100 PN10-16 DN100 PN25-40 Other
Inlet / Outlet Flange Face	RF..... RTJ.....	Raised face Ring Tongue Joint
Flange Material	-SS..... -O.....	SS 316L Other
Installation Type	-F..... -M.....	Fixed installation Mobile installation

Model	Suffix codes	Description
Always	-EJX530A.....	Always EJX530A-JCS7N-019EN/KU22
HMI version	-EW115.....	ESA EW115 for -10 +50 °C ambient operating temperature
Option	/BSW.....	Bypass line for BSW measurement with 1 Coriolis Flowmeter
	/WCIF.....	Watercut Intermittent Flow controlled with motorized valve
	/MV.....	Motorized Valves
	/FAT.....	Factory Acceptance Test
	/CST.....	SKIDM with castors
	/RT.....	Retention tray
	/BPG.....	Bypass line for gas, high GVF, EJX910 with compact orifice
	/HT.....	Heat Tracing for water cut line
	/PK.....	Pick-up truck or trailer compact version

OPTIONS DETAILS

/BSW

A vertical pipe is placed downstream the Coriolis and a small separation is performed at the outlet of the SKIDM to help the sampling of a small quantity of liquid through a ½" line.

Continuous sample (between 5 and 100kg/h) flows in a small bypass of the main metering lines, and it flows with the pressure drop generated in the main lines, no pump required.

This ½" line is equipped with a Coriolis Supreme/Intense 34, a densitometer that will measure the density of the liquid phase sampled and calculate the water cut.

The Supreme/Intense 34 communicates with the HMI by Modbus, the densities configured in the HMI are used to calculate the water cut

The water cut measurement is based on the density measurement of the liquid phase, in combination with the entered densities of Oil and Water, corrected at flowing temperature. This measurement is reliable, thanks to the sample taken downstream the Coriolis (that helps to homogenize the fluid), and can be performed even with a small aeration in the water cut line, using a specific correlation: aeration vs drive current. Please ask for more details about this performance: ventes@metisafrica.com



/WCIF

Watercut Intermittent Flow
 Motorized valve on the watercut line
 Usable for High GVF application and/or with entrained gas in the liquid (on high viscous oils for example).



/MV

Motorized valves on all flow lines

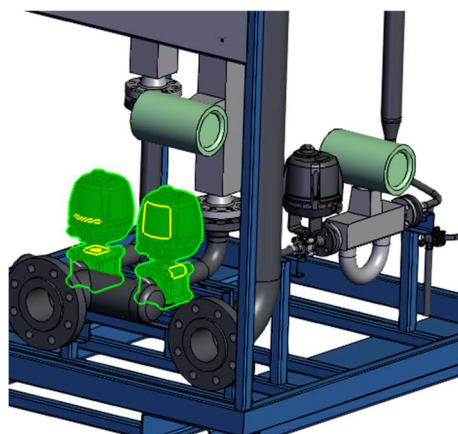

/FAT

FINAL INSPECTION AND DYNAMIC TESTS

Type of service: Final inspection and dynamic test Details of the service:

- SKIDM transportation from factory to workshops for assembly / programming and pre testing
- Preparation time before FAT including the implementation of specific tools in order to be able to carry out the dynamic tests with 3 different liquids (Water, diesel and salty water) to simulate different watercut levels and gas
- Workshops mobilization during the agreed duration of the service,
- Staff mobilization (METIS Africa 2 people) during the agreed duration of the service,
- Establishment of an adapted logistics for the good execution of the dynamic tests,
- Delivery of a FAT report.

Duration: 1 day

Water: 999 kg/m³ and 1 cPo @ 20°C

Diesel: ≈ 840 kg/m³ and 9.5 cPo @ 20°C

Salty water: 1050 kg/m³ and 1cPo @ 20°C

*** Gas: instrument air @ 8-11 barg / 20°C

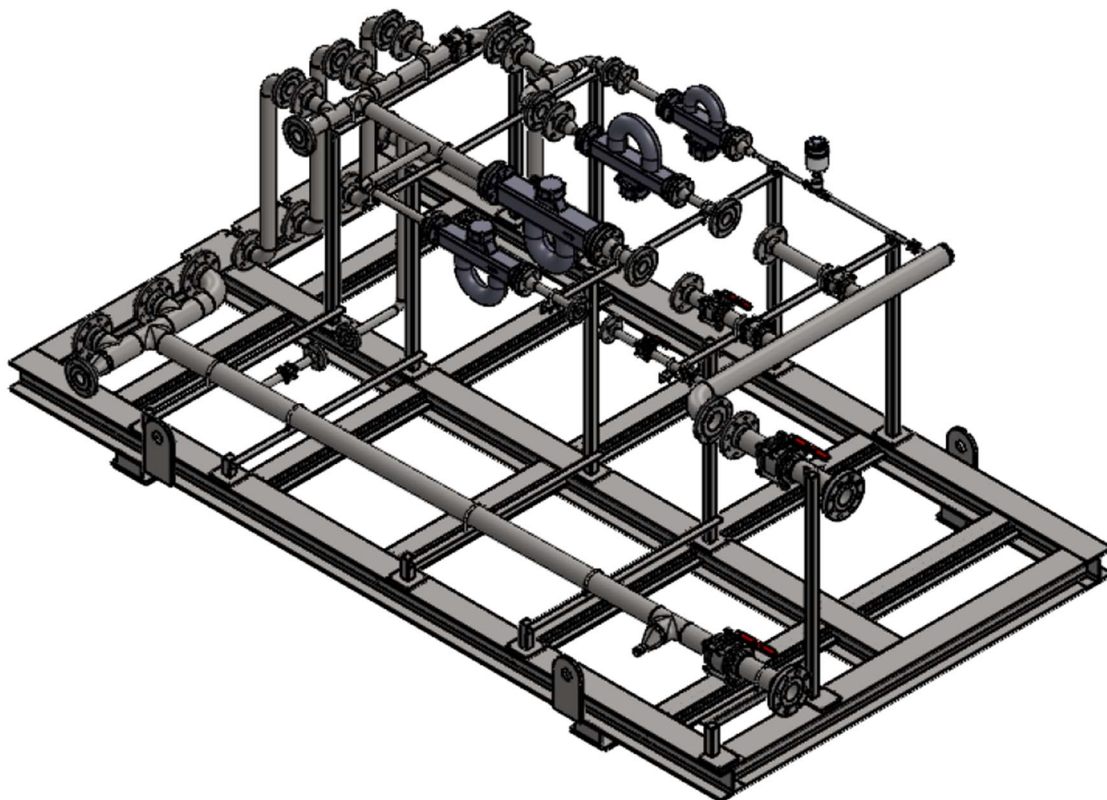

/CST

Our range of industrial medium duty caster wheels provide strength, durability and maneuverability.

With individual load capabilities per castor from 50kg up to 400kg each, these castors are specifically designed for industrial medium duty applications (for heavy duty castors on demand up to 800kg each).

These industrial medium duty top plate castors can be supplied in combinations of swivel castors, fixed or braked. The braked castors have a foot brake that is easily operated and simultaneously brakes both the swivel castor head and the wheel.

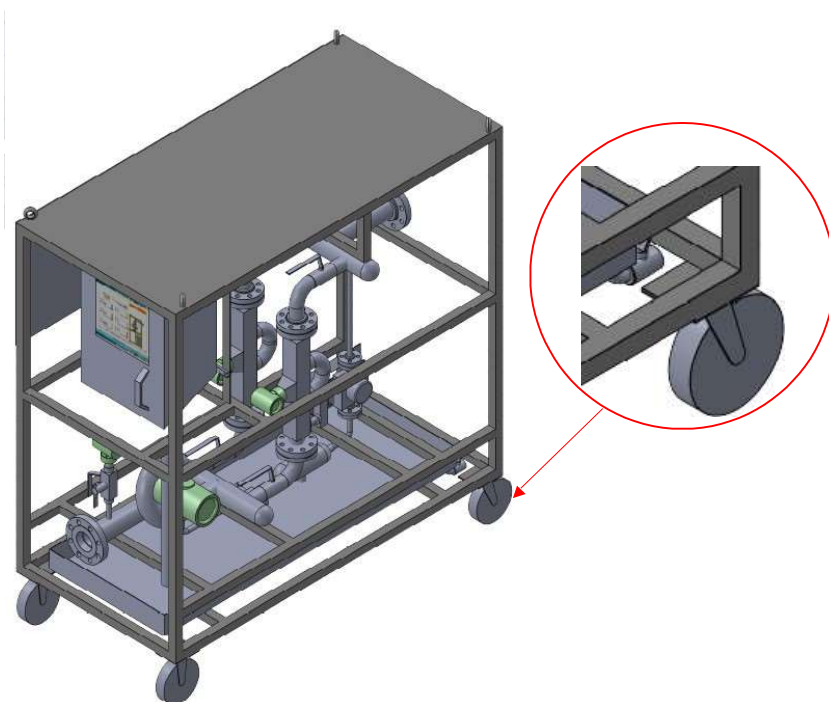

/RT

Retention tray in Inox 304L, SKIDM sizes with a purge valve

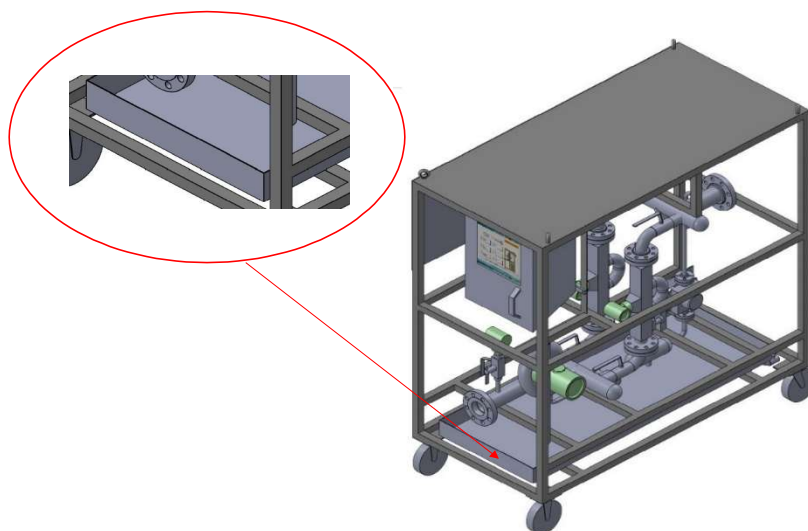

/BPG

For high GVF combined with high flow, we recommend to use /BPG option. At the cyclonic inlet of the SKIDM, a 3" pipe is connected vertically to remove gas from the 3 phases mixture. This gas flow is measured by an orifice plate and an EJX910 multivariable transmitter with respect to ISO 5167. The gas measurement of this bypass line is added to the gas measurement of the main lines of the SKIDM. The gas is then reinjected at the outlet of the SKIDM. This /BPG option helps to reduce the GVF of the mixture flowing in the main lines, and so increase the gas volume flow of the SKIDM.

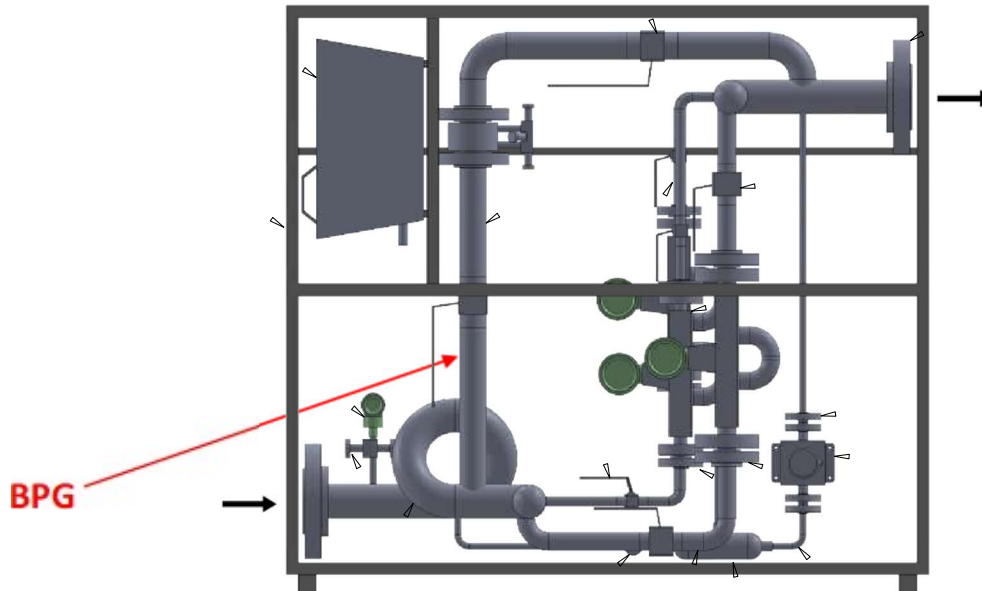

/HT

Electric heat tracing: Installation of an auto-controlled heating cable on the water cut line, to prevent any plugging on waxy and/or low temperature application

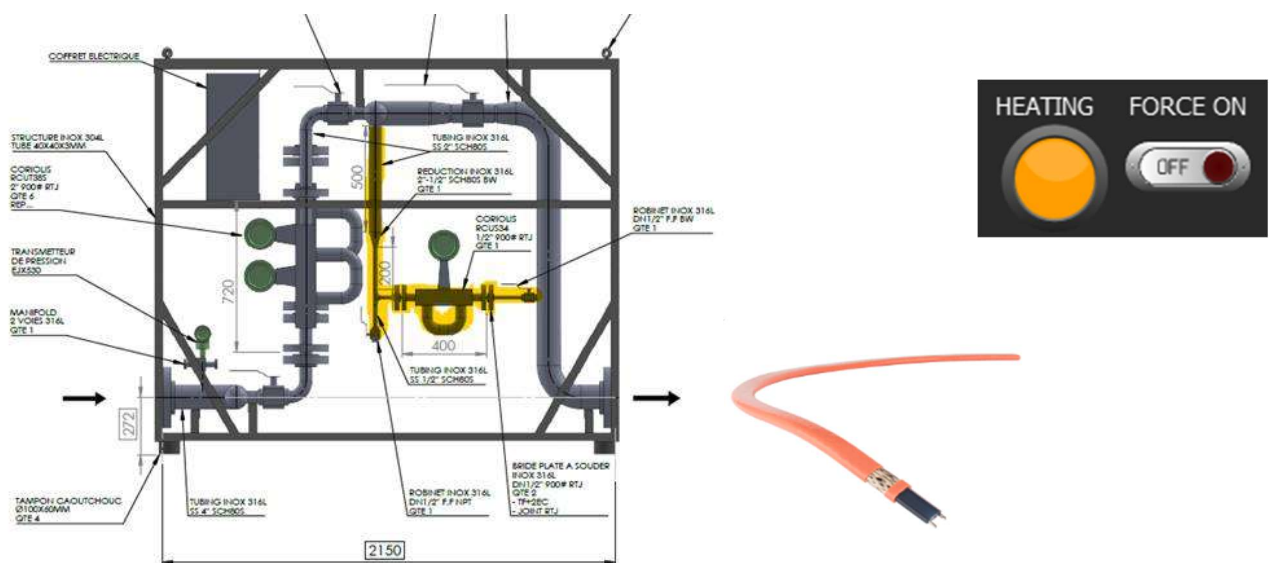

/PK

Trailer or pick-up truck version

Inlet – Outlet connection and display on the same side and compact footprint less than 1.4m x 1.4m (subject to design calculation)

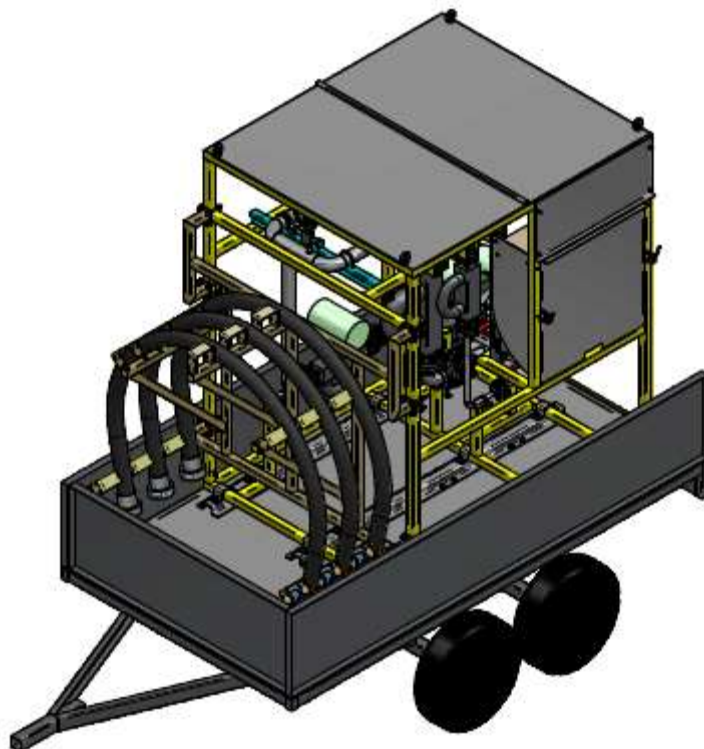

PERFORMANCE 5 BARG

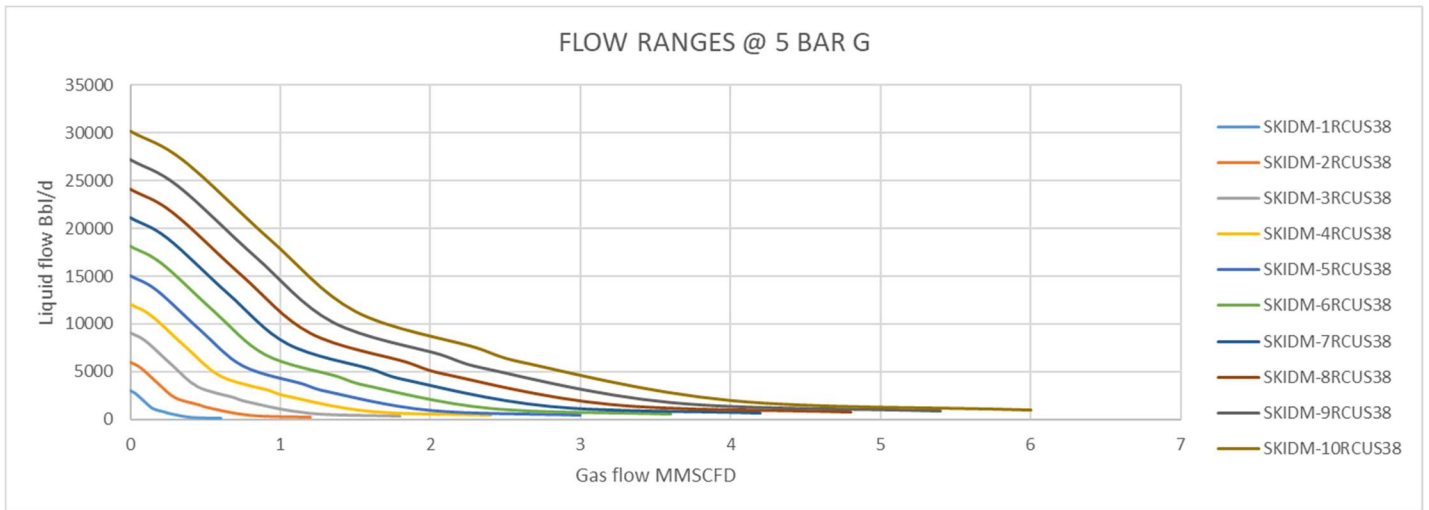

Example of SKIDM performance based on following process conditions:

Water density: 1100 kg/m³ / Oil density: 850 kg/m³ / Gas density: 0.8 kg/Sm³ / BSW: 50% / Pressure: 5 barg / Temperature: 40°C

* values without /BPG option. In case of /BPG option, the gas flow must be multiplied per 2

* values given for information only, for an accurate and dedicated study of an application, please contact ventes@metisafrica.com



PERFORMANCE 30 BARG

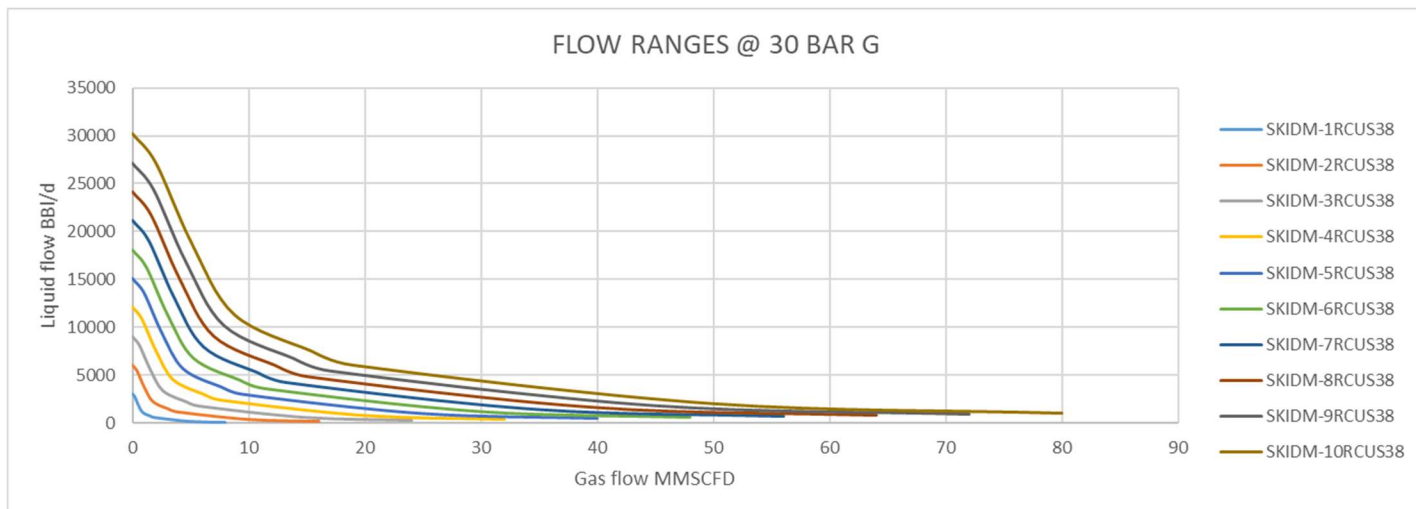

Example of SKIDM performance based on following process conditions:

Water density: 1100 kg/m³ / Oil density: 850 kg/m³ / Gas density: 0.8 kg/Sm³ / BSW: 50% / Pressure: 30 barg / Temperature: 40°C

* values without /BPG option. In case of /BPG option, the gas flow must be multiplied per 2

* values given for information only, for an accurate and dedicated study of an application, please contact ventes@metisafrica.com



PERFORMANCE 100 BARG

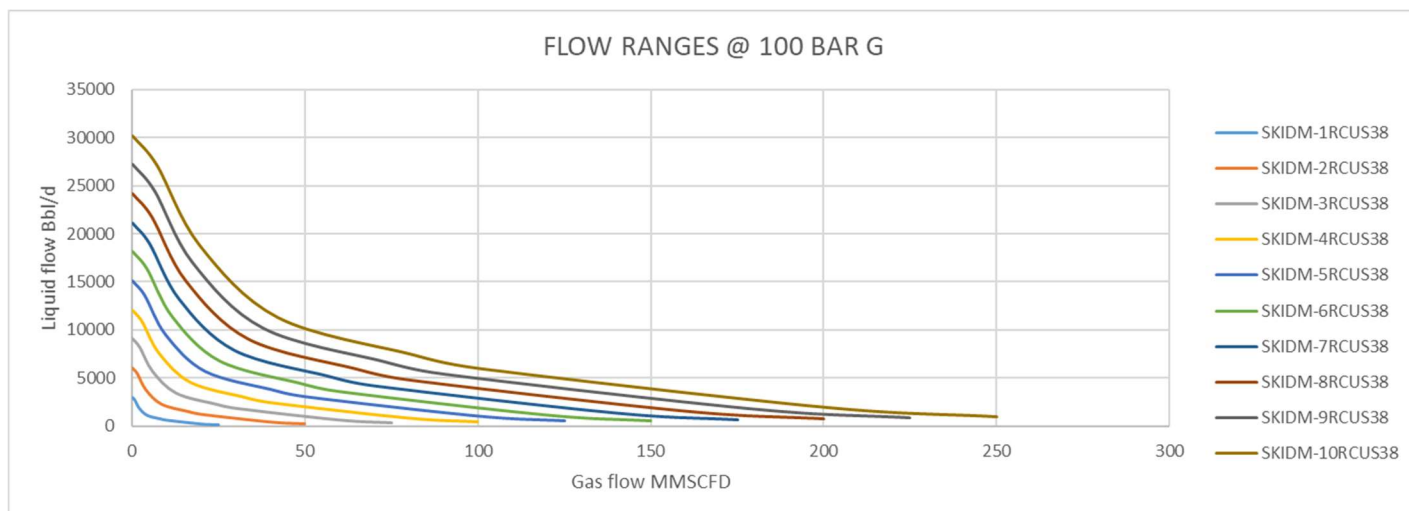

Example of SKIDM performance based on following process conditions:

Water density: 1100 kg/m³ / Oil density: 850 kg/m³ / Gas density: 0.8 kg/Sm³ / BSW: 50% / Pressure: 100 barg / Temperature: 40°C

* values without /BPG option. In case of /BPG option, the gas flow must be multiplied per 2

* values given for information only, for an accurate and dedicated study of an application, please contact ventes@metisafrica.com



APPROVALS AND DECLARATIONS OF CONFORMITY

CE marking	The Rotamass Total Insight meets the statutory requirements of the applicable EU Directives. By attaching the CE mark, Rota Yokogawa confirms conformity of the field instrument with the requirements of the applicable EU Directives. The EU Declaration of Conformity is enclosed with the product on a data carrier.
RCM	Rotamass Total Insight meets the EMC requirements of the Australian Communications and Media Authority (ACMA).
Ex approvals	All data relevant for explosion protection are included in separate Explosion Proof Type Manuals.
NACE	<p>Chemical composition of wetted materials 316L/316/1.4404/1.4401/1.4435 and Ni-Alloy C-22/2.4602 are conform to:</p> <ul style="list-style-type: none"> ▪ ANSI / NACE-MR0175 / ISO15156-2 ▪ ANSI / NACE-MR0175 / ISO15156-3 ▪ NACE MR0103 <p>For details please see Rota Yokogawa declaration about NACE conformity 8660001.</p>
Pressure equipment approvals	<p>The Rotamass Total Insight is in compliance with the statutory requirements of the applicable EU Pressure Equipment Directive (PED).</p> <p>The customer is fully responsible of selecting proper materials which withstand corrosive or erosive conditions. In case of heavy corrosion and/or erosion the instrument may not withstand the pressure and an incident may happen with human and/or environmental harm. Yokogawa will not take any liability regarding damage caused by corrosion or erosion. If corrosion or erosion may happen, the user has to check periodically if the necessary wall thickness is still in place.</p>
Functional safety	<p>The Rotamass Total Insight with HART communication type complies with the relevant safety management requirements of IEC 61508:2010 SIL3. The Rotamass Total Insight product families can be used to implement a SIL 2 safety function (with HFT = 0) or a SIL 3 safety function (with HFT = 1) with all its 4 – 20 mA outputs. The available number of outputs depends on the model code. For further information please contact Yokogawa sales department or look here http://www.exida.com/SAEL-Safety/yokogawa-electric-corporation-rotamass-ti-series</p>

APPROVALS AND DECLARATIONS OF CONFORMITY

Type	Approval or certification
ATEX	<p>EU Directive 2014/34/EU</p> <p>ATEX approval:</p> <p>DEKRA 15ATEX0023 X</p> <p>CE 0344 II2G or II2(1)G or II2D or II2(1)D</p> <p>Applied standards:</p> <ul style="list-style-type: none"> ▪ EN 60079-0 +A11 ▪ EN 60079-1 ▪ EN 60079-7 ▪ EN 60079-11 ▪ EN 60079-31
	<p>Remote transmitter (depending on the model code):</p> <p>Ex db [ia Ga] IIC T6 Gb or</p> <p>Ex db e [ia Ga] IIC T6 Gb or</p> <p>Ex db [ia Ga] IIB T6 Gb or</p> <p>Ex db e [ia Ga] IIB T6 Gb</p> <p>Ex db [ia Ga] [ia IIC Ga] IIB T6 Gb or</p> <p>Ex db e [ia Ga] [ia IIC Ga] IIB T6 Gb or</p> <p>Ex tb [ia Da] IIIC T75 °C Db</p> <p>Note: The marking on the product may be changed from Ex e to Ex eb based on statutory requirements.</p>
	<p>Remote sensor (depending on the model code):</p> <p>Ex ib IIC T6...T1 Gb or</p> <p>Ex ib IIB T6...T1 Gb</p> <p>Ex ib IIIC T150 °C Db or</p> <p>Ex ib IIIC T220 °C Db or</p> <p>Ex ib IIIC T350 °C Db</p>
	<p>Integral type (depending on the model code):</p> <p>Ex db ib IIC T6...T1 Gb or</p> <p>Ex db e ib IIC T6...T1 Gb or</p> <p>Ex db ib IIB T6...T1 Gb or</p> <p>Ex db e ib IIB T6...T1 Gb or</p> <p>Ex db ib [ia Ga] IIC T6...T1 Gb or</p> <p>Ex db e ib [ia Ga] IIC T6...T1 Gb or</p> <p>Ex db ib [ia IIC Ga] IIB T6...T1 Gb or</p> <p>Ex db e ib [ia IIC Ga] IIB T6...T1 Gb</p> <p>Ex ib tb IIIC T150 °C Db or</p> <p>Ex ib tb [ia Da] IIIC T150 °C Db</p> <p>Note: The marking on the product may be changed from Ex e to Ex eb based on statutory requirements.</p>

APPROVALS AND DECLARATIONS OF CONFORMITY

Type	Approval or certification
IECEX	IECEx approval: IECEx DEK 15.0016X Applied standards: <ul style="list-style-type: none"> ▪ IEC 60079-0 ▪ IEC 60079-1 ▪ IEC 60079-7 ▪ IEC 60079-11 ▪ IEC 60079-31
	Remote transmitter (depending on the model code): Ex db [ia Ga] IIC T6 Gb or Ex db e [ia Ga] IIC T6 Gb or Ex db [ia Ga] IIB T6 Gb or Ex db e [ia Ga] IIB T6 Gb Ex db [ia Ga] [ia IIC Ga] IIB T6 Gb or Ex db e [ia Ga] [ia IIC Ga] IIB T6 Gb or Ex tb [ia Da] IIIC T75 °C Db Note: The marking on the product may be changed from Ex e to Ex eb based on statutory requirements.
	Remote sensor (depending on the model code): Ex ib IIC T6...T1 Gb or Ex ib IIB T6...T1 Gb Ex ib IIIC T150 °C Db or Ex ib IIIC T220 °C Db or Ex ib IIIC T350 °C Db Integral type (depending on the model code): Ex db ib IIC T6...T1 Gb or Ex db e ib IIC T6...T1 Gb or Ex db ib IIB T6...T1 Gb or Ex db e ib IIB T6...T1 Gb or Ex db ib [ia Ga] IIC T6...T1 Gb or Ex db e ib [ia Ga] IIC T6...T1 Gb or Ex db ib [ia IIC Ga] IIB T6...T1 Gb or Ex db e ib [ia IIC Ga] IIB T6...T1 Gb Ex ib tb IIIC T150 °C Db or Ex ib tb [ia Da] IIIC T150 °C Db Note: The marking on the product may be changed from Ex e to Ex eb based on statutory requirements.

APPROVALS AND DECLARATIONS OF CONFORMITY

Type	Approval or certification
FM (CA/US)	FM approvals: <ul style="list-style-type: none"> ▪ US Cert No. FM16US0095X ▪ CA Cert No. FM16CA0031X Applied standards: <ul style="list-style-type: none"> ▪ Class 3600 ▪ Class 3610 ▪ Class 3615 ▪ Class 3810 ▪ Class 3616 ▪ NEMA 250 ▪ ANSI/IEC 60529 ▪ CSA-C22.2 No. 0-10 ▪ CSA-C22.2 No. 0.4-04 ▪ CSA-C22.2 No. 0.5-1982 ▪ CSA-C22.2 No. 94.1-07 ▪ CSA-C22.2 No. 94.2-07 ▪ CAN/CSA-C22.2 No. 60079-0 ▪ CAN/CSA-C22.2 No. 60079-11 ▪ CAN/CSA-C22.2 No. 61010-1-04 ▪ CSA-C22.2 No. 25-1966 ▪ CSA-C22.2 No. 30-M1986 ▪ CSA-C22.2 No. 60529
	Remote transmitter (depending on the model code): CL I, DIV 1, GP ABCD, CL II/III, DIV 1, GP EFG; CL I ZN 1 GP IIC; Associated Apparatus CL I/II/III DIV 1, GP ABCDEFG; CL I ZN 0 GP IIC Entity Temperature class T6 or CL I, DIV 1, GP ABCD, CL II/III, DIV 1, GP EFG; CL I ZN 1 GP IIC; Associated Apparatus CL I/II/III DIV 1, GP ABCDEFG; CL I ZN 0 GP IIC Temperature class T6; Associated Apparatus CL I/II/III DIV 1, GP ABCDEFG; CL I ZN 0 GP IIC Entity Temperature class T6 or CL I, DIV 1, GP CD, CL II/III, DIV 1, GP EFG; CL I ZN 1 GP IIB; Associated Apparatus CL I/II/III DIV 1, GP CDEFG; CL I ZN 0 GP IIB Entity Temperature class T6 or CL I, DIV 1, GP CD, CL II/III, DIV 1, GP EFG; CL I ZN 1 GP IIB; Associated Apparatus CL I/II/III DIV 1, GP CDEFG; CL I ZN 0 GP IIB Temperature class T6; Associated Apparatus CL I/II/III DIV 1, GP ABCDEFG; CL I ZN 0 GP IIB Entity Temperature class T6
	Remote sensor (depending on the model code): IS CL I/II/III, DIV 1, GP ABCDEFG; CL I, ZN 0, GP IIC Temperature class T* or IS CL I/II/III, DIV 1, GP ABCDEFG; CL I, ZN 0, GP IIB Temperature class T*

APPROVALS AND DECLARATIONS OF CONFORMITY

Type	Approval or certification
FM (CA/US)	Integral type (depending on the model code): CL I, DIV 1, GP ABCD, CL II/III, DIV 1, GP EFG; CL I ZN 1 GP IIC Temperature class T* or CL I, DIV 1, GP ABCD, CL II/III, DIV 1, GP EFG; CL I ZN 1 GP IIC Associated Apparatus CL I/II/III DIV 1 GP ABCDEFG; CL I ZN 0 GP IIC Entity Temperature class T* or CL I, DIV 1, GP CD, CL II/III, DIV 1, GP EFG; CL I ZN 1 GP IIB Temperature class T* or CL I, DIV 1, GP CD, CL II/III, DIV 1, GP EFG; CL I ZN 1 GP IIB Associated Apparatus CL I/II/III DIV 1 GP ABCDEFG; CL I ZN 0 GP IIC Entity Temperature class T*
INMETRO (BR)	INMETRO approval: DEKRA 16.0012X Applied standards: <ul style="list-style-type: none"> ▪ ABNT NBR IEC 60079-0 ▪ ABNT NBR IEC 60079-1 ▪ ABNT NBR IEC 60079-7 ▪ ABNT NBR IEC 60079-11 ▪ ABNT NBR IEC 60079-31
	Remote transmitter (depending on the model code): Ex db [ia Ga] IIC T6 Gb or Ex db e [ia Ga] IIC T6 Gb or Ex db [ia Ga] IIB T6 Gb or Ex db e [ia Ga] IIB T6 Gb Ex db [ia Ga] [ia IIC Ga] IIB T6 Gb or Ex db e [ia Ga] [ia IIC Ga] IIB T6 Gb or Ex tb [ia Da] IIIC T75 °C Db
	Remote sensor (depending on the model code): Ex ib IIC T6...T1 Gb or Ex ib IIB T6...T1 Gb Ex ib IIIC T150 °C Db or Ex ib IIIC T220 °C Db or Ex ib IIIC T350 °C Db
	Integral type (depending on the model code): Ex db ib IIC T6...T1 Gb or Ex db e ib IIC T6...T1 Gb or Ex db ib IIB T6...T1 Gb or Ex db e ib IIB T6...T1 Gb or Ex db ib [ia Ga] IIC T6...T1 Gb or Ex db e ib [ia Ga] IIC T6...T1 Gb or Ex db ib [ia IIC Ga] IIB T6...T1 Gb or Ex db e ib [ia IIC Ga] IIB T6...T1 Gb Ex ib tb IIIC T150 °C Db or Ex ib tb [ia Da] IIIC T150 °C Db

APPROVALS AND DECLARATIONS OF CONFORMITY

Type	Approval or certification
NEPSI (CN)	<p>Applied standards:</p> <ul style="list-style-type: none"> ▪ GB3836.1 ▪ GB3836.2 ▪ GB3836.3 ▪ GB3836.4 ▪ GB3836.19 ▪ GB3836.20
	<p>Remote transmitter (depending on the model code):</p> <p>Ex db [ia Ga] IIC T6 Gb or Ex db e [ia Ga] IIC T6 Gb or Ex db [ia Ga] IIB T6 Gb or Ex db e [ia Ga] IIB T6 Gb Ex db [ia Ga] [ia IIC Ga] IIB T6 Gb or Ex db e [ia Ga] [ia IIC Ga] IIB T6 Gb or Ex [iaD 20] tD A21 IP6X T75°C</p> <p>Note: The marking on the product may be changed from Ex e to Ex eb based on statutory requirements.</p>
	<p>Remote sensor (depending on the model code):</p> <p>Ex ib IIC T6...T1 Gb or Ex ib IIB T6...T1 Gb or Ex ibD 21 IP6X T150°C or Ex ibD 21 IP6X T220°C or Ex ibD 21 IP6X T350°C</p>
	<p>Integral type (depending on the model code):</p> <p>Ex db ib IIC T6...T1 Gb or Ex db e ib IIC T6...T1 Gb or Ex db ib IIB T6...T1 Gb or Ex db e ib IIB T6...T1 Gb or Ex db ib [ia Ga] IIC T6...T1 Gb or Ex db e ib [ia Ga] IIC T6...T1 Gb or Ex db ib [ia IIC Ga] IIB T6...T1 Gb or Ex db e ib [ia IIC Ga] IIB T6...T1 Gb or Ex ibD 21 tD A21 IP6X T150°C or Ex [iaD 20] ibD 21 tD A21 IP6X T150°C</p> <p>Note: The marking on the product may be changed from Ex e to Ex eb based on statutory requirements.</p>

APPROVALS AND DECLARATIONS OF CONFORMITY

Type	Approval or certification
PESO (IN)	<p>PESO approval: PESO approval is based on ATEX certification by DEKRA Certificate Number: DEKRA 15ATEX0023 X</p> <p>PESO approval is only valid for type of protection “d” flameproof enclosure. Option Q11 must be ordered for conformity of device with PESO requirements.</p> <p>PESO Equip. Ref. No. P4...: P400958/□ P400964/□ P400966/□ P400967/□ P400969/□ P400970/□ P400971/□ P400972/□ P400973/□</p> <p>Applied standards:</p> <ul style="list-style-type: none"> ▪ EN 60079-0 +A11 ▪ IS/IEC 60079-1 ▪ EN 60079-11
	<p>Remote transmitter (depending on the model code):</p> <p>Ex db [ia Ga] IIC T6 Gb or Ex db [ia Ga] IIB T6 Gb or Ex db [ia Ga] [ia IIC Ga] IIB T6 Gb</p>
	<p>Remote sensor (depending on the model code):</p> <p>Ex ib IIC T6...T1 Gb or Ex ib IIB T6...T1 Gb</p>
	<p>Integral type (depending on the model code):</p> <p>Ex db ib IIC T6...T1 Gb or Ex db ib IIB T6...T1 Gb or Ex db ib [ia Ga] IIC T6...T1 Gb or Ex db ib [ia IIC Ga] IIB T6...T1 Gb</p>

OPTIONAL APPROVALS AND DECLARATIONS OF CONFORMITY

Type	Approval or certification
Safety Label (TW)	Please refer to IECEx approval for specifications. A device with IECEx approval (model code position 11, value: SF2_) must be ordered to comply with Safety Label requirements. For export to Taiwan and to get the Safety Label the Yokogawa representative in Taiwan must be contacted in advance.
Ingress protection	IP66/67 and NEMA 4X
EMC	EU directive 2014/30/EU per EN 61326-1 Class A Table 2 and EN 61326-2-3
	NAMUR NE21
	RCM in Australia/New Zealand
	KC mark in Korea
	TR CU 020 in EAC area
Korea Ex	For further information please contact your Yokogawa representative
EAC Ex	
LVD	EU directive 2014/35/EU per EN 61010-1 and EN 61010-2-030
	TR CU 004 in EAC area
PED	EU directive 2014/68/EU per AD 2000 Code
	TR CU 032 in EAC area
Marine	DNV GL Type approval according to DNVGL-CP-0338 for options MC2 and MC3
RoHS	EU directive 2011/65/EU per EN 50581
WEEE	EU directive 2012/19/EU (Waste Electrical and Electronic Equipment) is only valid in the European Economic Area. This instrument is intended to be sold and used only as a part of equipment which is excluded from the WEEE directive, such as large-scale stationary industrial tools, a large-scale fixed installation etc., and therefore it is in principle fully compliant with WEEE directive. The instrument should be disposed of in accordance with applicable national legislations or regulations, respectively.
SIL	Exida Certificate per IEC61508:2010 Parts 1-7 SIL 2 @ HFT=0; SIL 3 @ HFT =1
NAMUR	NAMUR NE95 compliant
Metrological Regulations	Rotamass Total Insight is registered as a measuring instrument in the following countries: <ul style="list-style-type: none"> ▪ China ▪ Russia Please contact your Yokogawa representative regarding respective "Pattern Approval Certificate of Measuring Instruments" and export to these countries.
ASME	ASME B31.3 compliance
Sanitary Approvals	3-A Sanitary standards in combination with process connection types HS4, HS8 and HS9
	EHEDG in combination with process connection type HS4, HS8 and HS9

SKIDM ON YOUTUBE



English

<https://www.youtube.com/watch?v=g4wpaP-TRtc>

Portuguese

<https://www.youtube.com/watch?v=ESv139eqP2w>

French

<https://www.youtube.com/watch?v=NJiV9MAVYDk>

Spanish

<https://www.youtube.com/watch?v=4BsyuFrNS78>

METIS AFRICA

4 Domaine du Château, 25870 DEVECEY, France
 19th Floor, Conrad Hotel Offices, PO Box 26877 DUBAI, UAE
 E-Mail: ventes@metisafrica.com