

General Specifications

ADMAG TI Series
AXW Magnetic Flowmeter
[Size: 500 to 1800 mm (20 to 72 in.)]



GS 01E25D11-01EN

[Style: S2]

■ GENERAL DESCRIPTION

The ADMAG TI (Total Insight) Series AXW magnetic flowmeter has been developed based on Yokogawa's decades long experience in Magnetic Flowmeters. The AXW magnetic flowmeter continues the tradition of high quality and reliability that has become synonymous with the Yokogawa name.

The AXW magnetic flowmeter is ideal for general industrial process lines and water supply / sewage applications. With outstanding reliability and ease of operation and maintenance, developed on decades of field-proven experience, the AXW will increase user benefits while reducing total cost of ownership.

- Size: 25 to 1800 mm (1 to 72 in.)
- Lining: Fluorocarbon PTFE, various rubbers
- Process connection: ASME, EN, AS, and JIS

Note: For sizes from 25 to 400 mm (1 to 16 in.), or AXW4A remote transmitter, read general specifications (GS 01E24A01-01EN).
For AXG1A remote transmitter, read general specifications (GS 01E22C01-01EN).
For AXFA11G remote transmitter, read general specifications (GS 01E20C01-01E).



Integral Flowmeter

Remote Sensor

■ FEATURES

● Lineup Expansion

For sizes from 500 to 1000 mm (20 to 40 in.), not only the remote sensor but also the integral flowmeter has been lined up. When placing the display on the measuring site, installation and cable laying costs can be reduced by adopting the integral flowmeter.

● Multiple Inputs and Outputs

Maximum four inputs/outputs of current, pulse, and status signals can be selected.

● Improved Operation and Monitoring Function

Operation authority level setting for ensuring safety, process data trend display, display backlight flashing (Squawk) function, and data store / restore function with display unit internal memory or microSD card are available.

● Improved Maintainability

Diagnostic functions that contribute to preventive maintenance of the plant are installed. Diagnosis of the device (verification function) that can be executed without demounting from piping, and electrode adhesion diagnosis are available.

● Compliance with IEC61508 (optional specification)

This product can be used in safety instrumented systems up to SIL2 in simplex configuration and SIL3 in redundant configuration.

● Communication Protocol

HART, BRAIN, Modbus, FOUNDATION fieldbus, PROFIBUS PA

Refer to GS 01E21F02-01EN for FOUNDATION fieldbus communication type

Refer to GS 01E21F02-03EN for PROFIBUS PA communication type

■ GENERAL

Measuring Principle:

By applying the occurrence of electromotive force proportional to the flow velocity when fluid moves in the magnetic field, the flowmeter can measure the flow velocity of conductive liquid. It calculates the instantaneous flow rate, integrated flow rate, etc. from the measured flow velocity.

System Configuration:

Basic configuration: Sensor, Transmitter, Cable

	Function
Sensor	Detects the flow velocity
Transmitter	Amplifies a sensor and converts signals.
Cable(*)	Signal cable (for flow signal), excitation cable (for coil excitation)

*: Necessary for Remote type with construction separated to a sensor and a transmitter.

The excitation cable is to be supplied by customer except for Submersible-Use.

Main Element of Sensor:

	Function
Wetted Part	Lining, Electrodes, Grounding Ring
Non-wetted Part	Flanges, Housing, Excitation coil, Measuring pipe

Note: Grounding rings are for taking the reference electric potential from the process fluid in measuring the electromotive force, and are fixed at two locations, upstream and downstream of the flow. They are unnecessary when the reference potential is taken from customer piping. For details of grounding, read "Cautions on Selection and Installation".

Main Element of Transmitter:

Display unit, Setting keys, Amplifier unit (including I/Os and power supply unit)

■ CONSTRUCTION

Use:

Use	Specification
General-purpose	Non explosion protection for the use in non-hazardous area. Applicable to Integral Flowmeter, or Remote Sensor. IP Protection Grade: IP66/IP67
Submersible	Temporary submersion is possible. Applicable to Remote Sensor only. Note: Urethane resin potting is applied in the terminal box of a remote sensor. Signal and excitation cables (when optional code L### is not selected, cable length is each 30 m) are pre-wired and waterproof glands with union joints are attached at factory. IP Protection Grade: IP68 (Conforms to continuous immersion under the following test condition) Test Condition: 50 m below the surface of the water, equivalent to 0.5 MPa hydraulic pressure, for one month. In case of adverse conditions such as sewage and seawater, this is not the limit. Please protect the cable in some way. Also, waterproof and protect the cable separately by conduit piping, etc.

Construction:

Two types of Integral and Remote type.

Type	Construction
Integral type	Integrated structure of a sensor and a transmitter.
Remote type	Separated structure of a sensor and a transmitter, which are connected by a signal cable and an excitation cable(*).

*: To be supplied by customer except for Submersible-Use.

Combinable Transmitter:

Combined Transmitter:

Remote Sensor Size	Remote Transmitter
500 to 1000 mm (20 to 40 in.)	AXW4A, AXG1A, AXFA11G
1100 to 1800 mm (44 to 72 in.)	AXG1A, AXFA11G

Note 1: When changing the combination transmitter, readjustment of the meter factor by actual flow calibration is necessary to ensure accuracy.

Note 2: For sizes from 25 to 400 mm (1 to 16 in.), or AXW4A remote transmitter, read general specifications (GS 01E24A01-01EN).
For AXG1A remote transmitter, read general specifications (GS 01E22C01-01EN).
For AXFA11G remote transmitter, read general specifications (GS 01E20C01-01E).

Maximum Cable Length:

- 100 m (328 ft) for AXW4A remote transmitter with AX01C signal cable
- 200 m (656 ft) for AXG1A and AXFA11G remote transmitter with AX01C signal cable

Process Connection:

The flanges below are available.
For the availability of lining and size range, read "Model and Suffix Code".

Flange	ASME Class 150 AWWA C207 Class D EN PN6, PN10, PN16 JIS 10K, F12 AS2129 Table D, Table E AS4087 PN16
--------	---------------------------------------------------------------------------------------------------------------------

Electrode Construction:

PTFE Lining: Internal insertion type
Polyurethane Rubber Lining: External insertion type
Natural Hard Rubber Lining: Internal insertion type
Natural Soft Rubber Lining: Internal insertion type

Grounding Ring Construction:

Ring flat plate, with a handle for installation (*)
*: Grounding rings have a handle. Hook the pin attached to the handle on the outer circumference of the flange and install it between the flowmeter and piping.

Wetted Part Material:

Wetted Part	Material
Lining	Fluorocarbon PTFE Polyurethane rubber Natural hard rubber (with ethylene propylene diene rubber EPDM for sealing) Natural soft rubber
Electrode	Stainless steel 316L, HASTELLOY C-276 equivalent (*) *: ASTM B574 UNS N10276 or ASME SB-574 UNS N10276
Grounding Ring	Stainless steel 304, Stainless steel F304
Gasket (Note)	Gasket (optional code GR2): Styrene butadiene rubber (SBR)

Note: The description is about the material of gaskets supplied with flowmeter, be used between the sensor pipe and the grounding ring. Necessary gaskets are mostly to be supplied by customer.
For details of gaskets, read "Cautions on Selection and Installation".

Non-wetted Part Material:

Sensor Terminal Box:
Low copper aluminum alloy EN AC-43400
Transmitter Housing:
Low copper aluminum alloy EN AC-43400
Sensor Housing:

Size	Material
500 to 1000 mm (20 to 40 in.)	Carbon steel SPCC or its equivalent
1100 to 1800 mm (44 to 72 in.)	Carbon steel Q235B or its equivalent

Flange: Carbon steel A105
Measuring Pipe: Stainless steel 304

Coating:

General-purpose (Integral Flowmeter, and Remote Sensor):

Coated Part	Coating Specification
Sensor housing	Polyurethane resin solvent coating
Sensor flanges (for flange type)	
Sensor terminal box (for remote sensor, incl. cover)	Urethane curing type polyester resin powder coating
Transmitter housing (incl. cover)	

Submersible (Remote Sensor):

Coated Part	Coating Specification
Sensor housing	Non-tar epoxy resin solvent coating
Sensor flanges	
Sensor terminal box (incl. cover)	

Coating Color:

General-purpose
Mint green (RAL color number 190 30 15)
Submersible:
Black (close to RAL color number 9011)

Electrical Connection:

JIS G1/2 female
ANSI 1/2 NPT female
ISO M20 x 1.5 female

Electrical Connection Direction:

For Integral Flowmeter and Remote Sensor, the electrical connection direction can be specified from +90, +180, or -90 degree rotation when optional code RA, RB, or RC is ordering and also can be changed by customer after delivery. However, it can not be changed after delivery when Submersible, or district heating and cooling / condensation-proof use (optional code DHC) is selected.

Wiring Terminal:

Remote Sensor (Terminals for flow signal and excitation current):
M4 Screw type
Integral Flowmeter (Terminals for I/Os and power supply):
M4 Screw type (standard), or Clamp type (optional code CT)

Grounding:

Remote Sensor:
Grounding resistance 100 Ω or less
Integral Flowmeter:

Grounding resistance 10 Ω or less
Note: When the built-in lightning protector is not required, grounding resistance 100 Ω or less can be applied.

FUNCTIONS

Note: For sizes from 25 to 400 mm (1 to 16 in.), or AXW4A remote transmitter, read general specifications (GS 01E24A01-01EN).
For AXG1A remote transmitter, read general specifications (GS 01E22C01-01EN).
For AXFA11G remote transmitter, read general specifications (GS 01E20C01-01E).

Display and Setting:

Display unit (3 infrared switches with LCD) enables the user to set the parameters without opening the display cover.

Note: Parameter setting by setting tool such as HHT (handheld terminal) and FieldMate (device adjustment / management software) is also possible.

Display:

Full dot matrix LCD, 64 x 128 dots, with backlight dot reversal display available

Display Language (*):

Display Code 1:
English, French, German, Italian, Spanish, Portuguese, Russian and Japanese. The display languages are selectable and can be changed by customer.

Display Code 2:
English and Chinese. The display languages are selectable and can be changed by customer.

*: The setting is English when shipped from factory.

Display Screen Configuration:

Display Screen Item:
Status display (icon), Time (necessary to set the time at power-on), Data display (max. four lines), Infrared switch operation status

Flow Rate Screen:

Measured Data Screen or Online Trend Screen is available. Update period selectable from 0.2, 0.4, 1, 2, 4, and 8 seconds.

Measured Data Screen:
Display up to 4 data points simultaneously with numbers, bar graphs, icons, or character strings. Specify up to 8 points of data and change display data with infrared switches or automatic scroll function (scroll period 2, 4, or 8 seconds).

Selectable Data in Measured Data Screen:

BRAIN, HART, Modbus
Flow rate (%), Flow velocity, Volume flow rate, Mass flow rate, Totalizer 1, Totalizer 2, Totalizer 3, Adhesion level, Current output 1, Tag No., Communication protocol, Totalizer 1 count, Totalizer 2 count, Totalizer 3 count, Modbus info

Note: Modbus info is available for Modbus communication type.

FOUNDATION fieldbus

Flow rate (%), Flow velocity, Volume flow rate, Mass flow rate, Totalizer 1, Totalizer 2, Adhesion level, PD tag, Communication protocol, Total 1 count, Total 2 count, AI1 Flow rate, AI1 Flow rate (%), AI1.OUT, AI2.OUT, AI3.OUT, IT1.OUT, IT2.OUT, AR.OUT

PROFIBUS PA

Flow rate (%), Flow velocity, Volume flow rate, Mass flow rate, Totalizer 1, Totalizer 2, Totalizer 3, Adhesion level, Tag number, Communication protocol, Total 1 count, Total 2 count, Total 3 count, AI1.OUT, AI2.OUT, TOT1.OUT, TOT2.OUT, TOT3.OUT

Online Trend Screen:

Display one data as a trend graph. The display data can be changed with infrared switches or automatic scroll function (scroll period 2, 4, or 8 seconds) selecting up to four data.

Selectable Data in Online Trend Screen:

Flow rate (%), Flow velocity, Volume flow rate, Mass flow rate, Totalizer 1, Totalizer 2, Totalizer 3, Current output 1
Note: Totalizer 3 and Current output 1 are not available for FOUNDATION fieldbus or PROFIBUS PA.

Alarm Screen:

When an alarm occurs, the flow rate screen and the alarm screen are alternately displayed in the cycle (2, 4, or 8 seconds) linked with the flow rate screen update cycle. Select simple screen (single line display) or detail screen (with alarm countermeasure display).

NAMUR NE 107 Alarm Display Function:

Based on NAMUR NE 107, alarms are classified and displayed as follows. It can also be set to hide.
F: Failure
C: Function Check
S: Out of Specification
M: Maintenance Required"

Offline Trend Screen (when microSD card (optional code MC) is selected):

Data stored by the data logging function can be displayed on the trend screen. The selectable data is the same as that for the Online Trend Screen.

Display Backlight Flashing (Squawk) Function:

Display backlight can be set to flash once or continuously at 4-second cycle to identify the device.

Display Operation Authority:

Display operation authority level against the parameters can be controlled by selecting from operator, maintenance, or specialist by passcode.
Operator:

Only parameters related to display setting can be set.
Maintenance:

Only parameters related to display setting and zero adjustment can be set.

Specialist:

All parameters can be set.

Communication Function:

BRAIN:

Communication Signal:
Superimposed on the Current Output 1
Communication Line Condition:
Load Resistance:
250 to 450 Ω (including cable resistance)
Load Capacitance: 0.22 μF or less
Load Inductance: 3.3 mH or less
Input Impedance of Communicating Device:
10 k Ω or more (at 2.4 kHz)
Communication Distance:
Up to 1.5 km (0.93 miles), when polyethylene insulated PVC-sheathed cables (CEV cables) are used. Communication distance varies depending on the type of cable and wiring used.
Distance from Power Line:
15 cm (6 in.) or more. (Parallel wiring should be avoided)

HART:

Protocol Version: HART 7
Communication Signal:
Superimposed on the Current Output 1
Communication Line Condition:
Load Resistance:
230 to 600 Ω (including cable resistance)

Modbus:

Communication protocol:
 2-wire half duplex RS-485 Modbus
 Flow control: None
 Baud rate [bps]: 1200, 2400, 4800, 9600, 19200*,
 38400, 57600, 115200
 Start bit: 1 bit (Fixed)
 Stop bit: 1 bit*, 2 bits
 Parity bit: Odd, Even*, None
 Transfer mode:
 RTU (Remote Terminal Unit)
 ASCII
 Data length: 8 bits
 LSB (Least Significant Bit sent first)
 Slave address: 1* to 247
 Support function: See IM 01E21A02-05EN (Modbus communication type).
 Bus termination:
 Standard RS-485 bus termination
 ON (bus end), OFF* (not bus end)
 *: Factory default setting
 Modbus cable:
 3-Wire cable (twisted pair (D0, D1) and Common) with shield should be used. Wire gauge should be AWG24 or wider.
 The characteristic impedance of the cable higher than 100ohm may be preferred.

Line Termination:

Modbus cable requires Line Termination at each of the two ends of the bus to minimize the reflections. For details, please refer to "Modbus over serial line specification and implementation guide V1.02"

FOUNDATION fieldbus:

Output Signal:
 Fieldbus communication signal conforming to the standard specifications (H1) of FOUNDATION fieldbus.
Communication Requirements:
 Supply Voltage: 9 to 32 V DC
 Current Draw: 15mA (maximum)
 For details, please refer IM 01E21A02-03EN.
 Note: I/O2 (Pulse/Status Output1) is intended only for the calibration use.

PROFIBUS PA:

Output Signal:
 Fieldbus communication signal conforming to the standard specifications of PROFIBUS PA.
Communication Requirements:
 Supply Voltage: 9 to 32 V DC
 Current Draw: 15 mA (maximum)
 For details, please refer IM 01E21A02-04EN.
 Note: I/O2 (Pulse/Status Output1) is intended only for the calibration use.

Input/Output Function:

Input/Output Signal:

Input/Output up to four points can be selected from type A, E, G, 0, 6, F0, G0 in the table.

Input/Output (HART, BRAIN)

Type	Input/Output Signal				Communication and I/O Code	
	I/O1 Terminal	I/O2 Terminal	I/O3 Terminal	I/O4 Terminal	BRAIN	HART 7
Type A	Current Output 1 (Active)	Pulse/Status Output 1 (Passive)	None	None	-D	-E
Type E			Status Input (No-voltage)	Pulse/Status Output 2 (Passive)	-H	-J
Type G			Status Input (No-voltage)	Pulse/Status Output 2 (Active, without internal resistor)	-K	-L

Note: "Active" means no external power supply, "Passive" means external power supply is required.

Input/Output (Modbus)

Type	Input/Output Signal						Communication and I/O Code
	I/O1 Terminal	I/O2 Terminal	I/O3 Terminal		I/O4 Terminal		
			I/O3+	I/O3-	I/O4+	I/O4-	
Type 0	—	Pulse/Status Output (Passive)	—	Modbus C(Common)	Modbus B(D1)	Modbus A(D0)	-M
Type 6	Current Output 2 (Active)		—	—	—	—	-P

Note: "Active" means no external power supply, "Passive" means external power supply is required.

Input/Output (FOUNDATION fieldbus)

Type	Input/Output Signal				Communication and I/O code
	I/O1 Terminal	I/O2 Terminal	I/O3 Terminal	I/O4 Terminal	
Type F0	Fieldbus (Passive)	Pulse/Status Output 1 (Passive) * Intended only for the calibration use.	—	—	-F

Input/Output (PROFIBUS PA)

Type	Input/Output Signal				Communication and I/O code
	I/O1 Terminal	I/O2 Terminal	I/O3 Terminal	I/O4 Terminal	
Type G0	Fieldbus Passive	Pulse/Status Output Passive * Intended only for the calibration use.	—	—	-G

Input Signal**• Status Input (Dry contact) (Type E, G)**

Load Resistance: 200 Ω or less (ON), 100 kΩ or more (OFF)

Output Signal**• Current Output (Active) (Type A, E, G, 6)**

4 to 20 mA DC signal

Load Resistance: 750 Ω maximum, including cable resistance

• Pulse/Status Output (Passive) (Type A, E, G, 0, 6, F0)

Transistor contact output (open collector)

Contact Capacity: 30 V DC (OFF), 200 mA (ON)

Pulse Rate: 0.0001 to 10000 pps (pulse per second)

Pulse Width: 0.05, 0.1, 0.5, 1, 20, 33, 50, 100, 200, 330, 500, 1000, 2000 ms, or Duty cycle 50% (Maximum pulse width 5 minutes) configurable

Frequency Output Range: 1 to 12500 Hz

• Pulse/Status Output (Active)**Without Internal Resistor (Type G)****• Driving Electronic Counter**

Load Resistance: 1 kΩ or more, Internal Power Supply: 24 V DC ±20 %

Pulse Rate: 0.0001 to 10000 pps (pulse per second)

Pulse Width: 0.05, 0.1, 0.5, 1, 20, 33, 50, 100, 200, 330, 500, 1000, 2000 ms, or Duty cycle 50%

(Maximum pulse width 5 minutes) configurable

Frequency Output Range: 1 to 12500 Hz

• Driving Electromechanical Counter

Maximum Current: 150 mA, Internal Power Supply: 24 VDC ±20 %

Pulse Rate: 0.0001 to 2 pps (pulse per second)

Pulse Width: 20, 33, 50, or 100 ms configurable

• Digital communication (RS485 Modbus protocol) (Type 0, 6)

2-wire half duplex RS-485 Modbus

• Digital communication (FOUNDATION fieldbus) (Type F0)

Fieldbus communication signal conforming to the standard specifications (H1) of FOUNDATION fieldbus.

• Digital communication (PROFIBUS PA) (Type G0)

Fieldbus communication signal conforming to the standard specifications of PROFIBUS PA.

Flow Calculation Function:Excitation Method:

Pulsed DC Excitation

Span Setting:

Span flow can be set in units such as volume flow rate, mass flow rate, time, or flow rate value. The velocity unit can also be set.

Volume Flow Rate Unit:

kcf, cf, mcf, Mgal (US), kgal (US), gal (US), mgal (US), kbbbl (US)*, bbl (US)*, mbbl (US)*, μbbbl (US)*, Ml (megaliter), m³, kl (kiloliter), l (liter), cm³

*: "US Oil" or "US Beer" can be selected.

Mass Flow Rate Unit:

klb (US), lb (US), t (ton), kg, g

Velocity Unit:

ft, m (meter)

Time Unit:

s (second), min (minute), h (hour), d (day)

Mass Flow Rate Processing:

The mass flow rate V_m is obtained in the following expression.

$$V_m = V_f \times \rho$$

V_m : Mass flow rate [kg/s]

V_f : Volume flow rate [m³/s]

ρ : Density [kg/m³]

Damping Function (63% response):

Can be set for each measurement value of flow velocity, volume flow rate, and mass flow rate.

Output Damping:

For each measured value, the time constant for instantaneous value output (0.1 to 200.0 seconds, shipped with 3.0 seconds) and the time constant for totalization / pulse output (0.0 to 200.0 seconds, shipped with 3.0 seconds) can be individually set. In the case of piston pump etc., it is possible to measure pulsatile flow up to 1 Hz with output damping 0.1 seconds. However, note that decreasing damping time generally increases output fluctuation.

Display Damping:

A common time constant can be set for each screen display value of each measurement value. Time constant 0.0 to 200.0 seconds (shipped with 0.0 seconds).

Current Output:

Current signal (4 to 20 mA DC) proportional to instantaneous flow rate is output.

Pulse Output:

The totalized value of the flow rate is converted into the number of pulses converted by the pulse rate, and is output.

Frequency Output:

Frequency signal (Duty 50%) proportional to the instantaneous value of the flow rate is output. Output terminal is shared with pulse output.

Totalization Function:

Three independent totalizers can be allocated independently, including the start and stop of integration, for each measured value of volume flow rate and mass flow rate.

Totalization Type:

Forward / reverse difference flow totalization, Absolute value totalization, Forward direction totalization, Reverse direction totalization

Totalization Display:

Select from actual flow rate display or count value display scaled by counter conversion rate.

Low-cut Function:

For each current output, pulse output, or frequency output, the output signal below the set actual flow rate can be cut (*). It is independent for current output, common for pulse output and frequency output.

*: When "Forward and Reverse Flow Measurement" or "Absolute Range" is used, the output signal below the set actual flow rate value against the absolute value of the measured one is cut.

Output Processing Function:Multi-range:

Flow range can be switched to two ranges by status input or automatic switching. By status output, it is possible to identify in what range the measurement is being measured, and the status is also displayed on the display.

Forward and Reverse Flow Measurement:

Flow rate measurement in both forward and reverse directions is possible. By status output, it is possible to identify in which direction the measurement is being performed, and the status is also displayed on the display.

Absolute Range:

With 12 mA as flow rate zero, measurements in the forward (12 to 20 mA) and reverse (4 to 12 mA) directions are possible in a single range.

Totalization Switch:

Status signal is output when the totalized value becomes equal to or larger than the set value.

Preset Totalization:

By parameter setting or status input, the totalized value is preset to zero or a set value.

0% Signal Lock:

With status input, the current output is forcibly fixed to 0%. Mode is selectable whether to continue output processing for instantaneous flow rate display/pulse output/ flow rate totalization or to fix flow rate at 0.

Alarm Function:**Alarm Configuration:**

Alarms are classified into system alarm (device failure), process alarm, setting alarm, and warning. Alarm output availability can be selected for each item.

Current Output at Alarm Occurrence:

The current output at alarm occurrence is arbitrarily selected from 2.4 mA or less, 3.8 mA fixed, 4 mA fixed, 20.5 mA fixed, 21.6 mA or more, measured value, or HOLD.

Alarm Countermeasure Indication:

A specific countermeasure method can be displayed on the display when an alarm occurs.

Alarm Type:**System Alarm:**

CPU failure, A/D converter failure, Sensor coil circuit break (open), Sensor coil short circuit

Process Alarm:

Input signal error (signal overflow), Sensor empty pipe, Electrode adhesion (of insulator)

Setting Alarm:

Detect inconsistency in parameter setting

Warning:

Warning in a state where measurement can be continued.

Alarm History:

Keep history of up to four alarms.

Verification Function:

Function to diagnose the soundness of the device itself. Diagnose the magnetic circuit, excitation circuit, arithmetic processing circuit, etc. offline (i.e. flow measurement function stopped) and display the result without demounting the device from piping.

Data Management Function:**Store / Restore of Parameters:**

Main parameters can be stored up and restored using nonvolatile memory of display unit. The restore can also be used for copying parameters to another device (except for parameters under unmatched specification for the devices). When optional code MC is selected, this function is also available by using microSD card.

Data Logging Function (when microSD card (optional code MC) is selected):

It is possible to log up to four process data at the same time. In addition to displaying the logged results on the trend screen, it is also possible to connect the microSD card to a PC and retrieve the data.

Logging Cycle:

1 second, 10 seconds, 30 seconds, 1 minute, 5 minutes, 30 minutes, 1 hour

Logging Time:

10 minutes, 30 minutes, 1 hour, 3 hours, 12 hours, 24 hours, 72 hours, 240 hours, 720 hours, 1440 hours

Logging Data:

Flow velocity, Volume flow rate, Mass flow rate, Adhesion level

Data Security During Power Failure:

Protection of data, such as parameters and integrated values, by nonvolatile memory at power failure.

Factory Default Parameter Restore:

It is possible to restore the parameters to the values that were set at the time of factory shipment.

Lightning Protection:

Built-in lightning protector for input/output terminals and power supply terminal.

Test Standard: IEC61000-4-5**Test Method:**

Series mode 1 kV / Common mode 2 kV
Surge waveform 8/20 μ S

■ CONFORMITY STANDARDS**EMC:**

EN61326-1 Class A, Table 2 (For use in industrial locations)
EN61326-2-3, EN61326-2-5
EN61000-3-2 Class A
EN61000-3-3

Safety Requirements*:

* Applicable in the following cases:

- In the case of AXG1A remote transmitter and AXW remote sensor of 1000mm or less.
- In the case of AXW4A remote transmitter and AXW remote sensor of 1000mm or less.
- In the case of AXW integral flowmeter of 1000 mm or less.

EN61010-1
EN61010-2-030
CAN/CSA-C22.2 No.61010-1
CAN/CSA-C22.2 No.61010-2-30
CAN/CSA-C22.2 No.94.2
UL 61010-1 (3rd Edition)
UL 61010-2-030 (1st Edition)
UL 50E
IEC 60529

Altitude at Installation Site:

Max. 2000 m above sea level

Installation Category (Overvoltage category): II**Micro Pollution Degree: 2****Macro Pollution Degree: 4****Protection Degree:**

IP66/IP67, Type 4X (CSA)
IP68* (CSA, Only Submersible type)

* IP 68 (conforming to continuous dive under the following test conditions)

Test conditions: 1 month with fresh water and 50 m under water surface (hydraulic pressure 0.5 MPa). In case of adverse conditions such as sewage and seawater, this is not the limit. Please protect the cable in some way.

Morocco conformity mark :

This conformity mark indicates that the product complies with Moroccan safety and EMC requirements.

The size over 1000 mm (40 in.) is not applicable. Combination of AXFA11 transmitter and AXW sensor is not applicable.

Drinking Water Certification (optional code NSF):
NSF61 Drinking Water Certification

Functional safety standard:

IEC 61508 (Parts 1 - 7: 2010; compliant with Functional Safety of Electrical/Electronic/Programmable Electronic Safety-related Systems)
This product can be used in safety instrumented systems up to SIL2 in simplex configuration and SIL3 in redundant configuration.
For details, please refer to IM01E21A21-02EN (ADMAG TI Series AXG/AXW Magnetic Flowmeter Safety Manual).

Calibration takes place at reference conditions as below.
Medium: Water, Density: 0.9 to 1.1 kg/l
Medium temperature: 10 to 35°C (50 to 95°F)
(Average temperature 22.5°C (72.5°F))
Ambient temperature: 10 to 35°C (50 to 95°F)
Process pressure (absolute):
0.1 to 0.2 MPa (15 to 29 psi)
Reference Standards:
JIS B 7554, ISO 4185, ISO 5168, ISO 20456, BS EN 29104

■ PERFORMANCE

Accuracy (Pulse Output):

- **AXW Integral Flowmeter, AXW Remote Sensor combined with AXW4A / AXG1A / AXFA11 Remote Transmitter**

Size mm (in.)	Flow Velocity V m/s (ft/s)	Standard Accuracy (Calibration Code B)
500 to 1000 (20) (40)	$V < 0.3$ (1.0)	±2.0 mm/s
	$0.3 \leq V \leq 10$ (1.0) (33)	±0.35% of rate ±1.0 mm/s
1100 to 1800 (44) (72)	$V < 0.3$ (1.0)	±3.0 mm/s
	$0.3 \leq V < 1.0$ (1.0) (33)	±0.4% of rate ±1.8 mm/s
	$1.0 \leq V \leq 10$ (3.3) (33)	±0.5% of rate ±1.0 mm/s

For sizes 500 mm (20 in.) to 1000 mm (40 in.)

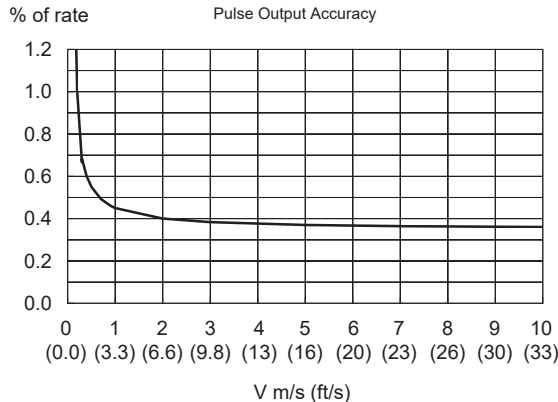

F01.ai

For sizes 1100 mm (44 in.) to 1800 mm (72 in.)

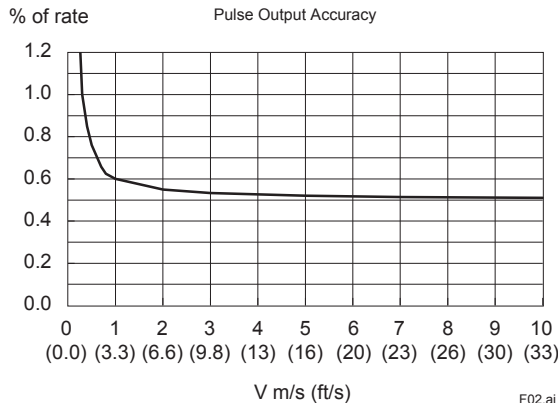

F02.ai

Note: The accuracy above is the result of calibration test at our water flow facility before shipment. It is defined by the integrated value of the pulse output. As for the current output accuracy, add ±8 μA (±0.05% of span) to the accuracy above.

Repeatability:

- ±0.2% of rate (Velocity 1 m/s (3.3 ft/s) or more)
- ±0.1% of rate ± 1 mm/s (Velocity below 1 m/s (3.3 ft/s))

Measurement Range:

Minimum Span Velocity:
With AXG1A Remote Transmitter
0.1 m/s (for sizes 500 to 1800 mm, 20 to 72 in.)
Integral Type, with AXG4A or AXFA11 Remote Transmitter
0.1 m/s (for sizes 500 to 1000 mm, 20 to 40 in.)
0.3 m/s (for sizes 1100 to 1800 mm, 44 to 72 in.)
Maximum Span Velocity:
10 m/s (for sizes 500 to 1800 mm, 20 to 72 in.)
Note: For details of span flow rate, read "Sizing Data", and "Ordering Information".

Power Consumption:

Integral Type: 13 W
Remote Type: 13 W (with AXW4A Remote Transmitter)
20 W (with AXFA11 Remote Transmitter)
32 W (with AXG1A Remote Transmitter)

Note: The power consumption is the same as above regardless of the communication and I/O type.

Insulation Resistance:

Integral Flowmeter:

- Between power supply terminals and ground terminal:
100 MΩ/500 V DC
- Between power supply terminals and input/output terminals:
100 MΩ/500 V DC
- Between ground terminal and input/output terminals:
20 MΩ/100 V DC or 125 V DC
- Between input/output terminals*:
20 MΩ/100 V DC or 125 V DC

*: Not applicable for I/O3 and I/O4+ of Modbus

Remote Sensor:

- Between signal terminals:
100 MΩ/500 V DC
- Between signal terminals and common terminal:
100 MΩ/500 V DC
- Between excitation current terminal and signal / common terminals:
100 MΩ/500 V DC

Withstand Voltage:

Integral Flowmeter:

- Between power supply terminals and ground terminal:
1400 V AC for 2 seconds
- Between power supply terminals and input/output terminals:
1400 V AC for 2 seconds

■ NORMAL OPERATING CONDITIONS

Ambient Temperature:

-10 to 60°C (14 to 140°F)

Note: Minimum temperature is limited according to minimum fluid temperature of sensor's specification. Read description of "Fluid Temperature and Pressure".

Ambient Humidity:

0 to 100%

Note: Lengthy continuous operation at 95% or more is not recommended.

Power Supply:

Power Supply Code 1:

AC Type:

Rated Power Supply: 100 to 240 V AC, 50/60 Hz

Operating Voltage Range: 80 to 264 V AC

DC Type:

Rated Power Supply: 100 to 120 V DC

Operating Voltage Range: 90 to 130 V DC

Power Supply Code 2:

AC Type:

Rated Power Supply: 24 V AC, 50/60 Hz

Operating Voltage Range: 20.4 to 28.8 V AC

DC Type:

Rated Power Supply: 24 V DC

Operating Voltage Range: 20.4 to 28.8 V DC

Supply Voltage and Power Supply Cable Length for Power Supply Code 2:

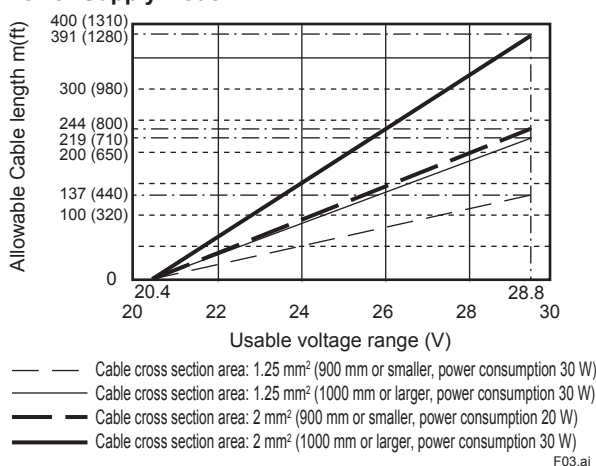

Fluid Conductivity:

Size 500 to 1000 mm (20 to 40 in.):

20 μ S/cm or larger

Size 1100 to 1800 mm (44 to 72 in.):

50 μ S/cm or larger

Fluid Temperature and Pressure:

The following table shows the usable temperature and pressure range of the sensor in each specification. It is also limited by the flange pressure rating of the process connection.

Lining	Fluid Temperature	Fluid Pressure
PTFE (Note)	-10 to 100°C (14 to 212°F)	0 to 1 MPa (0 to 145 psi)
Natural hard rubber	-5 to 80°C (23 to 175°F)	0 to 1 MPa (0 to 145 psi)
Natural soft rubber	-10 to 70°C (14 to 158°F)	0 to 1 MPa (0 to 145 psi)
Polyurethane rubber	-10 to 40°C (14 to 104°F)	-0.1 to 1 MPa (-14.5 to 145 psi)

Note: In the case of PTFE lining, avoid the negative pressure inside the measuring pipe.

■ CAUTIONS ON SELECTION AND INSTALLATION

Combined Transmitter:

In the following cases, combine with AXG1A remote transmitter. If it is considered that the flow noise in the fluid could be large because of high concentration slurry, etc., it is recommended to combine with AXG1A remote transmitter.

- When mounting remote transmitter to wall or panel
- When cable length exceeds 100 m
- When using 5 or more input/output terminals

Lining:

PTFE Lining:

It is excellent in chemical resistance and suitable for general chemical fluids.

Polyurethane Rubber Lining:

It has abrasion resistance and suitable for low slurry fluid of water, water-based solution, muddy water, or seawater.

Natural Hard Rubber Lining:

It has chemical resistance and suitable for acid / alkali fluid of low concentration, and also wastewater / sewage.

Natural Soft Rubber Lining:

It is a material that can reduce wear of the lining due to slurry mixed fluid. If the concentration of slurry is high, separate measures are required for the electrode part, so please consult us.

Grounding Ring:

The grounding ring can be selected as an optional specification. It is unnecessary to use it for metal piping which has no lining. In that case, connect the piping and the sensor flange part with grounding wire supplied by customer (see the figure below). Be sure to select the grounding ring when installed at plastic or lining piping.

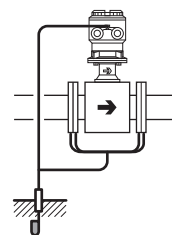

F04.ai

Installing PTFE Sensor:

When installing PTFE lining sensor to the piping and tightening it, be careful not to apply uneven tension and torque to the PTFE. It is recommended to install the PTFE lining sensor with grounding rings or with short pipes at both upstream and downstream side fixed beforehand.

Noise Avoidance:

The flowmeter should be installed away from electrical motors, transformers, and other power sources in order to avoid interference with measurement.

When installing multiple magnetic flowmeters, put the flowmeter the distance at least 5D (D: Size of Model code) apart from the next one. If they are different in size, define that of the bigger one as D.

Mounting of Flowmeters and Required Straight Pipe Length:

Based on JIS B 7554 "Magnetic Flowmeters" and our piping condition test data, we recommend the piping conditions as shown in the following figures. This is not always enough when the piping line incorporates multiple conditions at the same time.

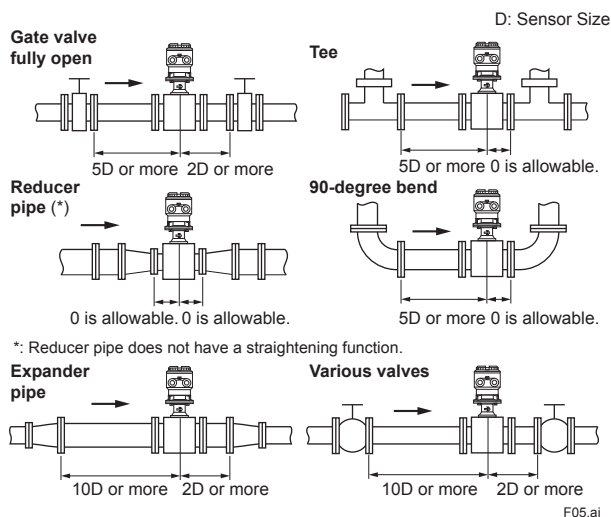

Required Straight Pipe Length

- Do not install anything in the vicinity that may interfere with the magnetic field, induced signal voltages, or flow velocity distributions of the flowmeter.
- A straight run may not be required on the downstream side of the flowmeter. However, if a downstream valve or other fitting causes irregularity or deviation in flows, provide a distance run of 2D to 3D on the downstream side.
- The valves shall be mounted on the downstream side so that deviated flows do not occur in the sensor and to avoid startup from an empty condition.
- In case the piping conditions are compounded, install on the straight pipe section where the upstream part is sufficiently rectified.

Maintaining Stable Fluid Conductivity:

Do not install the flowmeter where fluid conductivity tends to become uneven. If chemicals are fed near the upstream side of a magnetic flowmeter, they may affect the flow rate indication. To avoid this situation, it is recommended that the chemical feed ports be located on the downstream side of the flowmeter. If it is unavoidable that chemicals must be fed on the upstream side, provide a sufficient straight pipe length (approximately 50D or more) to ensure the proper mixture of fluids.

Mounting Positions:

- Pipe fully filled with liquid

It is essential that pipes remain fully filled at all times, otherwise flow rate indication may be affected and measurement errors may occur.

Piping shall be designed so as to maintain the sensor filled with fluids.

Vertical mounting is effective in such cases as when fluids tend to separate or solid matter may precipitate.

When employing vertical mounting, direct the fluid from the bottom to the top to ensure that the pipe remains fully filled.

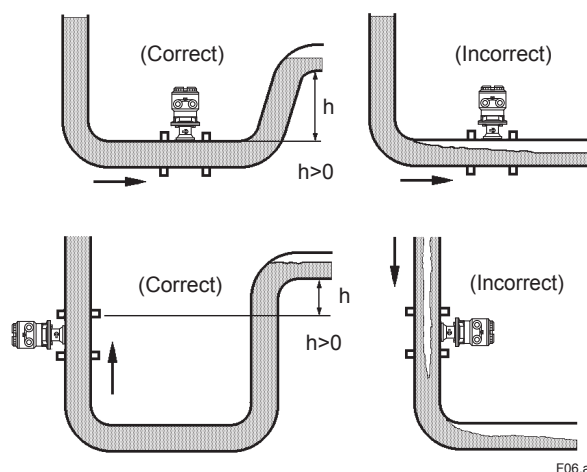

Mounting Positions

- **Avoiding Air Bubbles**

If air bubbles arise in the pipe, flow rate indication may be affected and measurement errors may occur.

In cases where the fluid contains air bubbles, piping must be designed to prevent them from accumulating in the magnetic flowmeter sensor.

If a valve exists near the sensor, try to mount the sensor on the valve's upstream side in order to prevent a possible reduction of pressure inside the pipe, thereby avoiding the possibility of air bubbles.

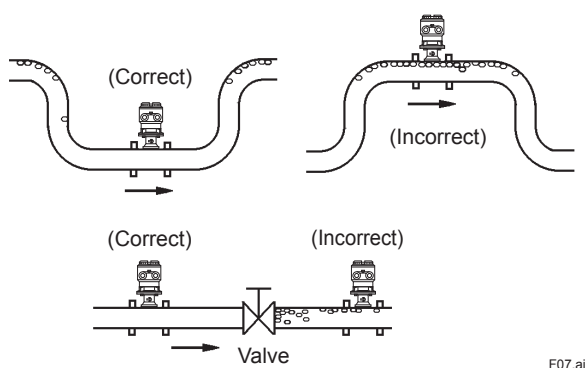

F07.ai

Avoiding Air Bubbles

- **Mounting Orientation:**

Install the magnetic flowmeter so that the electrodes position is not perpendicular to the ground. Otherwise it may cause the measuring errors because air bubbles at upper side or slurry at downside covers the electrode.

Mount the terminal box of a remote sensor and the transmitter of an integral flowmeter above the piping to prevent water from entering them.

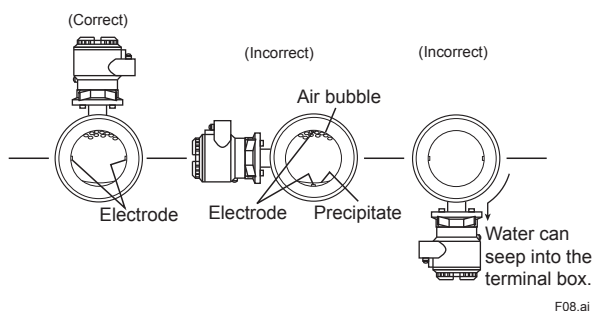

F08.ai

Mounting Orientation

- **Gaskets and Grounding Rings:**

Necessary gaskets for piping connection are as below depending on the choice of grounding rings. Use sheet gaskets designed to fit for flange standard. The GF type-1 gaskets by JIS G 3443-2 should be used for the JIS F12 flange models in sizes 1100 mm (44 in.) or more. In this case, the gasket groove is required on the customer pipe flanges. The thickness of gasket should be 2 mm (0.08 in.) to 5 mm (0.2 in.) for size 1000 mm (40 in.) or less, and 5 mm (0.2 in.) or more for size 1100 mm (44 in.) or more. The type of gasket should be a kind of soft rubber, or its equivalent in hardness.

- Without grounding rings

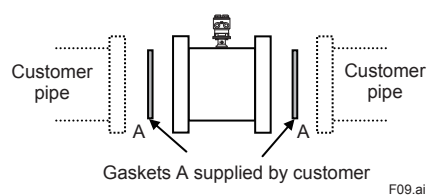

F09.ai

When using the GF type-1 gaskets, the gasket groove is required as mentioned above.

- With grounding rings (optional code GR1)

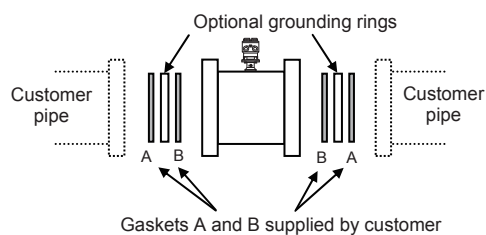

F10.ai

It is recommended to use the same gasket for A and B. Both gaskets A and B are to be supplied by customer.

When polyurethane or natural soft rubber lining, the gaskets B are not necessary.

- With grounding rings (optional code GR2)

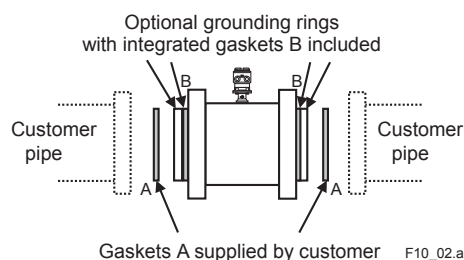

F10_02.ai

This is available for the models with process connection JIS F12 in sizes 1100 mm (44 in.) or more. Only gaskets A are to be supplied by customer. Use soft rubber gasket, PTFE-sheathed non-asbestos gasket, or its equivalent in hardness. The grounding rings are installed onto the sensor with gaskets B when shipped from factory.

■ MODEL AND SUFFIX CODE

● Process Connections other than JIS F12

Model	Suffix Code	Description	Applicable Condition
AXW500		Magnetic Flowmeter (500 mm (20 in.))	
AXW600		Magnetic Flowmeter (600 mm (24 in.))	
AXW700		Magnetic Flowmeter (700 mm (28 in.))	
AXW800		Magnetic Flowmeter (800 mm (32 in.))	
AXW900		Magnetic Flowmeter (900 mm (36 in.))	
AXW10L		Magnetic Flowmeter (1000 mm (40 in.))	
AXW12L		Magnetic Flowmeter (1200 mm (48 in.))	Only for Remote Sensor
AXW14L		Magnetic Flowmeter (1400 mm (56 in.))	Only for Remote Sensor
AXW16L		Magnetic Flowmeter (1600 mm (64 in.))	Only for Remote Sensor
AXW18L		Magnetic Flowmeter (1800 mm (72 in.))	Only for Remote Sensor
Use	G	General-purpose type	
	W	Submersible type	Only for Remote Sensor
Converter, Communication and I/O	#	#: D, H, K Integral Flowmeter with 4 to 20 mA DC Output BRAIN and I/O (Type A, E, G). See "Details".	500 mm (20 in.) to 1000 mm (40 in.)
	#	#: E, J, L Integral Flowmeter with 4 to 20 mA DC Output HART 7 and I/O (Type A, E, G). See "Details".	500 mm (20 in.) to 1000 mm (40 in.)
	#	#: M, P Integral Type, Modbus Communication	500 mm (20 in.) to 1000 mm (40 in.)
	-F	Integral Flowmeter with FOUNDATION fieldbus I/O	500 mm (20 in.) to 1000 mm (40 in.)
	-G	Integral Flowmeter with PROFIBUS PA I/O	500 mm (20 in.) to 1000 mm (40 in.)
	-B	Remote Sensor for Combined Use with AXG1A	
	-N	Remote Sensor for Combined Use with AXFA11	
Power Supply	1	100 to 240 V AC / 100 to 120 V DC	Only for Integral Flowmeter
	2	24 V AC / DC	Only for Integral Flowmeter
	N	None (Remote Sensor)	Only for Remote Sensor
Lining (*1)	F	Fluorocarbon PTFE	See "Process Connection"
	H	Natural Hard Rubber	See "Process Connection"
	D	Natural Soft Rubber	See "Process Connection"
	U	Polyurethane Rubber	See "Process Connection"
Electrode Material (*1)	L	Stainless Steel 316L (AISI 316L SS Equivalent)	
	H	HASTELLOY C-276 Equivalent	
Electrode Structure	1	Non-replaceable	
Grounding Structure (*2)	N	None (*3), available for optional code GR1	
Process Connection (*4)	-CA1	ASME B16.5 Class 150 Flange (Carbon Steel)	500 mm (20 in.) to 600 mm (24 in.) for lining code F, H, D, U
		ASME B16.47 Series A Class 150 Flange (Carbon Steel)	700 mm (28 in.) to 1000 mm (40 in.) for lining code F, H, D, U
	-CB1	AWWA C207 Class D Flange (Carbon Steel)	700 mm (28 in.) to 1000 mm (40 in.) for lining code F, H, D, U 1200 mm (48 in.) for lining code H
	-CEJ	EN1092-1 PN6 Flange (Carbon Steel)	1200 mm (48 in.) to 1800 mm (72 in.) for lining code H
	-CEK	EN1092-1 PN10 Flange (Carbon Steel) (fluid pressure up to 0.6 MPa)	
		EN1092-1 PN10 Flange (Carbon Steel) (fluid pressure up to 1 MPa)	500 mm (20 in.) to 1000 mm (40 in.) for lining code F, H, D, U 1200 mm (48 in.) to 1800 mm (72 in.) for lining code H
	-CE2	EN1092-1 PN16 Flange (Carbon Steel) (fluid pressure up to 1 MPa)	500 mm (20 in.) to 1000 mm (40 in.) for lining code F, H, D, U
	-CJ1	JIS B2220 10K Flange (Carbon Steel)	
	-CS1	AS2129 Table D Flange (Carbon Steel)	500 mm (20 in.) to 1000 mm (40 in.) for lining code F, H, D, U
	-CS2	AS2129 Table E Flange (Carbon Steel)	
-CT1	AS4087 PN16 Flange (Carbon Steel)	1200 mm (48 in.) for lining code H	
Lay Length	N	Standard	
Electrical Connection	-0	JIS G1/2 female	
	-2	ANSI 1/2 NPT female	Only for General-purpose Type
	-4	ISO M20 x 1.5 female	Only for General-purpose Type
Indicator	1	With Indicator (English, Multi-language)	Only for Integral Flowmeter
	2	With Indicator (English, Chinese)	Only for Integral Flowmeter
	N	Without Indicator / Remote Sensor	
Calibration	B	Standard	
Optional Specifications		/# Refer to optional specification table.	

*1: ⚠ Users must consider the characteristics of selected wetted parts material and influence of process fluids. The use of inappropriate materials can result in the leakage of corrosive process fluids and cause injury to personnel and/or damage to plant facilities. It is also possible that the instrument itself can be damaged and that fragments from the instrument can contaminate the user's process fluids. Be very careful with highly corrosive process fluids such as hydrochloric acid, sulfuric acid, hydrogen sulfide, sodium hypochlorite, and high-temperature steam (150°C [302°F] or more). Contact Yokogawa for detailed information of the wetted parts material.

*2: Select optional grounding rings (optional code GR1) if necessary. For example, grounding rings are necessary for plastic piping or lining piping.

*3: "None" is applicable only for metal piping and wiring for grounding will be necessary so that the electric potentials between flowtube and piping flange should be the same.

*4: The process connection is a fitting dimension that can be connected to the target flange standards. The usable range is also limited by fluid temperature and pressure conditions.

● Process Connection JIS F12

Model	Suffix Code	Description	Applicable Condition
AXW500		Magnetic Flowmeter (500 mm (20 in.))	
AXW600		Magnetic Flowmeter (600 mm (24 in.))	
AXW700		Magnetic Flowmeter (700 mm (28 in.))	
AXW800		Magnetic Flowmeter (800 mm (32 in.))	
AXW900		Magnetic Flowmeter (900 mm (36 in.))	
AXW10L		Magnetic Flowmeter (1000 mm (40 in.))	
AXW11L		Magnetic Flowmeter (1100 mm (44 in.))	Only for Remote Sensor
AXW12L		Magnetic Flowmeter (1200 mm (48 in.))	Only for Remote Sensor
AXW13L		Magnetic Flowmeter (1350 mm (54 in.))	Only for Remote Sensor
AXW15L		Magnetic Flowmeter (1500 mm (60 in.))	Only for Remote Sensor
AXW16L		Magnetic Flowmeter (1600 mm (64 in.))	Only for Remote Sensor
AXW18L		Magnetic Flowmeter (1800 mm (72 in.))	Only for Remote Sensor
Use	G	General-purpose type	
	W	Submersible type	Only for Remote Sensor
Converter, Communica- tion and I/O	#	#: D, H, K Integral Flowmeter with 4 to 20 mA DC Output BRAIN and I/O (Type A, E, G). See "Details".	500 mm (20 in.) to 1000 mm (40 in.)
	#	#: E, J, L Integral Flowmeter with 4 to 20 mA DC Output HART 7 and I/O (Type A, E, G). See "Details".	500 mm (20 in.) to 1000 mm (40 in.)
	#	#: M, P Integral Type, Modbus Communication	500 mm (20 in.) to 1000 mm (40 in.)
	-F	Integral Flowmeter with FOUNDATION fieldbus I/O	500 mm (20 in.) to 1000 mm (40 in.)
	-G	Integral Flowmeter with PROFIBUS PA I/O	500 mm (20 in.) to 1000 mm (40 in.)
	-B	Remote Sensor for Combined Use with AXG1A	
	-N	Remote Sensor for Combined Use with AXFA11	
Power Supply	1	100 to 240 V AC / 100 to 120 V DC	Only for Integral Flowmeter
	2	24 V AC / DC	Only for Integral Flowmeter
	N	None (Remote Sensor)	Only for Remote Sensor
Lining (*1)	U	Polyurethane Rubber	
Electrode Material (*1)	L	Stainless Steel 316L (AISI 316L SS Equivalent)	
	H	HASTELLOY C-276 Equivalent	
Electrode Structure	1	Non-replaceable	
Grounding Structure (*2)	N	None (*3), available as optional code GR1 or GR2	
Process Connection	-CG1	JIS F12 Flange (Carbon Steel)	
Lay Length	N	Standard	
Electrical Connection	-0	JIS G1/2 female	
	-2	ANSI 1/2 NPT female	Only for General-purpose Type
	-4	ISO M20 x 1.5 female	Only for General-purpose Type
Indicator	1	With Indicator (English, Multi-language)	Only for Integral Flowmeter
	2	With Indicator (English, Chinese)	Only for Integral Flowmeter
	N	Without Indicator / Remote Sensor	
Calibration	B	Standard	
Optional Specifications		/# Refer to optional specification table.	

*1:  Users must consider the characteristics of selected wetted parts material and influence of process fluids. The use of inappropriate materials can result in the leakage of corrosive process fluids and cause injury to personnel and/or damage to plant facilities. It is also possible that the instrument itself can be damaged and that fragments from the instrument can contaminate the user's process fluids. Be very careful with highly corrosive process fluids such as hydrochloric acid, sulfuric acid, hydrogen sulfide, sodium hypochlorite, and high-temperature steam (150°C [302°F] or more). Contact Yokogawa for detailed information of the wetted parts material.

*2: Select optional grounding rings (optional code GR1 or GR2) if necessary. For example, grounding rings are necessary for plastic piping or lining piping.

The optional code GR1 is only for sizes 500 mm (20 in.) to 1000 mm (40 in.).

The optional code GR2 is only for sizes 1100 mm (44 in.) to 1800 mm (72 in.).

*3: "None" is applicable only for metal piping and wiring for grounding will be necessary so that the electric potentials between flowtube and piping flange should be the same.

*4: The process connection is a fitting dimension that can be connected to the target flange standards. The usable range is also limited by fluid temperature and pressure conditions.

● Details: Communication and I/O (HART type, BRAIN type)

Type	Communication and I/O Code		Number of Input and Output			
	BRAIN	HART 7	Current Output (Active)	Pulse/Status Output (Passive)	Status Input (No-voltage)	Pulse/Status Output (Active, without internal resistor)
Type A	-D	-E	1	1	—	—
Type E	-H	-J	1	2	1	—
Type G	-K	-L	1	1	1	1

● Details: Communication and I/O (Modbus type)

Type	Communication and I/O Code	Number of Input and Output		
	Modbus	Current Output (Active)	Pulse/Status Output (Passive)	Current Input (Active)
Type 0	-M	—	1	—
Type 6	-P	1	1	—

● Details: Communication and I/O (FOUNDATION fieldbus type)

Type	Communication and I/O Code	Number of Input and Output		
	FOUNDATION fieldbus	Current Output (Active)	Pulse/Status Output (Passive)	Current Input (Active)
Type F0	-F	—	1	—

● Details: Communication and I/O (PROFIBUS PA type)

Type	Communication and I/O Code	Number of Input and Output		
	PROFIBUS PA	Current Output Active	Pulse/Status Output Passive	Current Input Active
Type G0	-G	—	1	—

■ OPTIONAL CODE

● Application, Usage, Operating Function, and Transmitter Wiring Terminal

●: Applicable —: Not Applicable

Item	Specification and Applicable Condition	Applicable Model			Code
		General-purpose		Submersible	
		Integral Flowmeter	Remote Sensor	Remote Sensor	
DC Noise Cut Circuit (for electrolytic bath)	Built-in DC noise cut circuit. It works effectively when the fluid conductivity is 50 $\mu\text{S}/\text{cm}$ or more. Empty pipe detection, electrode adhesion diagnosis, electrode potential measurement, and wetted resistance measurement function can not be used.	●	—	—	ELC
For District Heating and Cooling or Condensation-proof	Urethane resin potting is applied in the terminal box of a remote sensor. Signal and excitation cables (when optional code L### is not selected, cable length is each 30 m) are pre-wired and waterproof glands with union joints are attached at factory. Select JIS G1/2 for the electrical connections. When optional code DHC is selected, the optional code of plastic and waterproof glands can not be selected.	—	●	—	DHC
User-specified Signal and Excitation Cable Length	Change the length of signal cable and excitation cable pre-wired for a remote sensor of Submersible type or one with optional code DHC. Specify the cable length in the "####" with the numerical value three digits (001 to 200) as multiple of 1 meter (e.g. 001, 002, or 005) for a length up to 5 m, as multiple of 5 meters up to 100 m (e.g. 010, 020, or 100), or as multiple of 10 meters up to 200 m (e.g. 110, 120, or 200). The maximum cable length is 100 m in combination with the AXW4A transmitter, and 200 m in combination with the AXG1A or AXFA11 transmitter. When optional code L### is not selected, a 30-meter length cable as standard is pre-wired.	—	●	●	L###

● Application, Usage, Operating Function, and Transmitter Wiring Terminal (Continued)

●: Applicable —: Not Applicable

Item	Specification and Applicable Condition	Applicable Model			Code
		General-purpose		Submersible	
		Integral Flowmeter	Remote Sensor	Remote Sensor	
Mass Unit Setting	The flow rate calculation is performed in mass unit. In addition to fluid density, specify span flow rate, pulse weight, and totalization weight in mass unit. For specifying procedures, read "Ordering Information". For remote sensor, specified parameters are set in the transmitter that is ordered in combination.	●	●	●	MU
Signal Down on Failure	Set the current output signal as follows when shipped. Output signal at CPU failure or alarm occurrence: 2.4 mA (-10 %) or less (The standard setting is 21.6 mA (110%) or more at CPU failure or alarm occurrence.) Not with Communication and I/O code -M, -F.	●	—	—	C1
Signal Down on Failure (NAMUR NE 43 Compliant)	Set the current output signal as follows when shipped. - Output signal limits: 3.8 to 20.5 mA - Output signal at CPU failure or alarm occurrence: 2.4 mA (-10%) or less Not with Communication and I/O code -M, -F.	●	—	—	C2
Signal Up on Failure (NAMUR NE 43 Compliant)	Set the current output signal as follows when shipped. - Output signal limits: 3.8 to 20.5 mA - Output signal at CPU failure or alarm occurrence: 21.6 mA (110%) or more Not with Communication and I/O code -M, -F.	●	—	—	C3
microSD Card	A microSD card slot is added to the display unit, and a microSD card (capacity 1 GB, format FAT 16) is inserted when shipped. When using parameter store / restore function with microSD card, and/or data logging function, specify optional code MC. Be careful that the microSD card slot is not mounted unless optional code MC is specified.	●	—	—	MC
NSF61 Drinking Water Certification	Compliant to NSF61 Drinking Water Certification. UL marking (NSF61 approval) is indicated on the sensor. When needing NSF61 approval, specify optional code NSF. Water contact temperature: CLD (23°C) Optional code NSF can be selected with the followings: • Size: 500 to 1000 mm (20 to 40 in.) • Lining: F (Fluorocarbon PTFE), U (Polyurethane Rubber) • Electrode Material: L (Stainless Steel 316L (AISI 316L SS Equivalent)) • Process Connection: -CA1 (ASME Class 150 Flange: Carbon Steel) -CB1 (AWWA C207 Class D Flange: Carbon Steel) -CE1 (EN1092-1 PN10 Flange: Carbon Steel) -CE2 (EN1092-1 PN16 Flange: Carbon Steel) Not applicable with the following Optional Code: • Grounding Rings: GR2 • Japan Domestic Sales: PJ	●	●	●	NSF
EAC Approval and Russian Pattern Approval Marking	EAC approval marking and Russian pattern approval marking are indicated on the nameplate. When the product is used in Russian Federation, specify optional code VR. Size: 500 to 1000 mm (20 to 40 in.) Not with Converter, Communication and I/O code -N.	●	●	●	VR
EAC Approval Marking without Russian Pattern Approval Marking	EAC approval marking is indicated on the nameplate. (no Russian pattern approval marking). When the product is used in EEU except for Russian Federation, specify optional code VE. Size: 500 to 1000 mm (20 to 40 in.) Not with Converter, Communication and I/O code -N.	●	●	●	VE
SIL Certification	Compliant to the functional safety standard IEC61508. When the product is used in a safety instrumented system, specify optional code SL. This product can be used in safety instrumented systems up to SIL2 in simplex configuration and SIL3 in redundant configuration. Not applicable with the following specifications: • Communication and I/O: M, P, F, G • Optional code: ELC (DC noise cut circuit)	●	—	—	SL

● Application, Usage, Operating Function, and Transmitter Wiring Terminal (Continued)

●: Applicable —: Not Applicable

Item	Specification and Applicable Condition	Applicable Model			Code
		General-purpose		Submersible	
		Integral Flowmeter	Remote Sensor	Remote Sensor	
Transmitter Wiring Terminal Clamp Type	Change the power supply and input/output wiring terminal of integral flowmeter from standard M4 screw-type to clamp type.	●	—	—	CT
Japan Domestic Sales	Identifies the final destination as Japan. Mandatory when the final destination is Japan. Not applicable when the final destination is not in Japan.	●	●	●	PJ

● Grounding Ring, Tag Plate, Direction of Electrical Connection, Waterproof Gland

●: Applicable —: Not Applicable

Item	Specification and Applicable Condition	Applicable Model			Code
		General-purpose		Submersible	
		Integral Flowmeter	Remote Sensor	Remote Sensor	
Grounding Rings	Stainless steel 304 (AISI 304 SS Equivalent), a set of two rings. This is not available for models with process connection JIS F12 of sizes 1100 mm (44 in.) to 1800 mm (72 in.). Read "CAUTIONS ON SELECTION AND INSTALLATION" on necessary gaskets.	●	●	●	GR1
Grounding Rings	Stainless steel F304 (AISI 304 SS Equivalent), a set of two rings with gaskets "B". This is available only for models with process connection JIS F12 of sizes 1100 mm (44 in.) to 1800 mm (72 in.). Read "CAUTIONS ON SELECTION AND INSTALLATION" on necessary gaskets.	●	●	●	GR2
Stainless Steel Tag Plate	The pendant type tag plate (Stainless steel 304) is wired around the flowmeter neck. Select optional code SCT when necessary in addition to that on the nameplate, on which the Tag No. is inscribed. Plate size (Height x Width): Approx. 12.5 mm x 40 mm (4.92 in. x 15.7 in.)	●	●	●	SCT
Direction Change of Electrical Connection	Rotate the transmitter of integral flowmeter or the terminal box of remote sensor and change the direction of electrical connection. For specifying procedures, read "Ordering Information". Optional code RA: +90 degree, RB: +180 degree, RC: -90 degree	●	●	●	RA
		●	●	●	RB
		●	●	●	RC
G3/4 Female Waterproof Glands (Type W)	2 pcs. of waterproof gland with JIS G3/4 female, and no blanking plug. Available only for electrical connection code -0 (JIS G1/2 female thread).	—	●	—	EW
Waterproof Glands (Type G)	2 pcs. of waterproof gland, and no blanking plug. Available only for electrical connection code -0 (JIS G1/2 female thread).	—	●	—	EG
Waterproof Glands (Type U)	2 pcs. of waterproof gland with union joint, and no blanking plug. Available only for electrical connection code -0 (JIS G1/2 female thread).	—	●	—	EU
Waterproof Glands (Type G2)	2 pcs. of waterproof gland, and a blanking plug. Available only for electrical connection code -0 (JIS G1/2 female thread).	●	—	—	EG2
Waterproof Glands (Type G3)	3 pcs. of waterproof gland, and no blanking plug. Available only for electrical connection code -0 (JIS G1/2 female thread).	●	—	—	EG3
Waterproof Glands (Type U2)	2 pcs. of waterproof gland with union joint, and a blanking plug. Available only for electrical connection code -0 (JIS G1/2 female thread).	●	—	—	EU2
Waterproof Glands (Type U3)	3 pcs. of waterproof gland with union joint, and no blanking plug. Available only for electrical connection code -0 (JIS G1/2 female thread).	●	—	—	EU3
Plastic Glands (Type P2)	2 pcs. of plastic gland, and a blanking plug. Available only for electrical connection code -0 (JIS G1/2 female thread).	●	—	—	EP2
Plastic Glands (Type P3)	3 pcs. of plastic gland, and no blanking plug. Available only for electrical connection code -0 (JIS G1/2 female thread).	●	—	—	EP3

● Certificate, Calibration, and Various Test

●: Applicable —: Not Applicable

Item	Specification and Applicable Condition	Applicable Model			Code
		General-purpose		Submersible	
		Integral Flowmeter	Remote Sensor	Remote Sensor	
Material Certificate	Material certificate is issued. Target Parts: Measuring Pipe, Electrodes, Flanges (for flange type), Grounding Rings (optional)	●	●	●	M01
Calibration Certificate (Level 2)	The Declaration and the Calibration Equipment List are issued.	●	●	●	L2
Calibration Certificate (Level 3)	The Declaration and the Primary Standard List are issued.	●	●	●	L3
Calibration Certificate (Level 4)	The Declaration and the Yokogawa Measuring Instruments Control System are issued.	●	●	●	L4
Specified Span Five-point Calibration	With the customer's specified span, the actual flow inspection of 5 points around 0, 25, 50, 75, and 100% is performed. Instead of the flow inspection at the standard flow rate of 2 m/s (6.56 ft/s), the result of flow inspection with the customer specified span is described in a test certificate (QIC). For specifiable spans, read "Ordering Information".	●	●	●	SC
Hydrostatic Test	The water pressure depending on the process connection is applied to the lining (measuring pipe) for 10 minutes to check that there is no leakage, and the result is described in a test certificate (QIC). For the test water pressure on each process connection, see the separate table.	●	●	●	T01

● Details: Water Pressure of Hydrostatic Test (Optional Code T01)

Process Connection Code	Process Connection	Water Pressure (MPa)
CA1	ASME Class 150	1.5
CB1	AWWA Class D	1.25
CEJ	EN PN6	0.9
CEK	EN PN10 *1	0.9
CE1	EN PN10 *2	1.5
CE2	EN PN16 *2	1.5
CJ1	JIS 10K	1.5
CG1	JIS F12	1.5
CS1	AS2129 Table D	1.05
CS2	AS2129 Table E	1.5
CT1	AS4087 PN16	1.5

*1: Fluid pressure rating up to 0.6 MPa

*2: Fluid pressure rating up to 1 MPa

■ ACCESSORIES

- Blanking Plug: 1 to 2 pcs.

Note: Accessories differ depending on specifications to be selected.

■ TERMINAL CONFIGURATION AND WIRING

Remote Sensor:

<To be wired to Remote Transmitter>

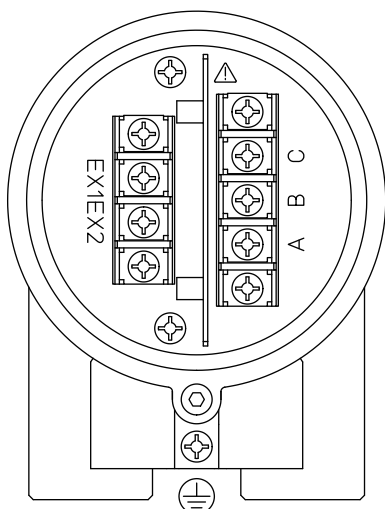

Terminal Symbol	Description
A B C	Flow Signal Output
EX1 EX2	
⊕	

F11.ai

Note: When submersible use or optional code DHC is selected, waterproof glands with union joints and cables are attached.

Integral Flowmeter:

<To be wired to Power Supply and I/Os>

M4 Screw Type

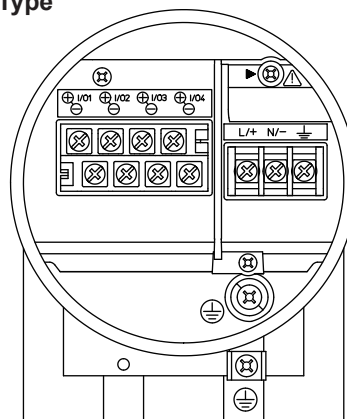

Clamp Type

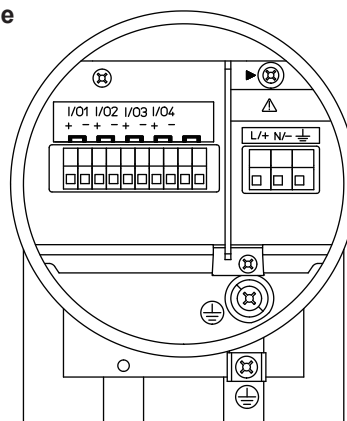

Terminal Symbol	Description
▶	Shorting Screw (Need to be fixed for normal operation)
⊕	Functional Grounding
N/ L/+	Power Supply
I/O4 - I/O4 + I/O3 - I/O3 + I/O2 - I/O2 + I/O1 - I/O1 +	Selected Input/Output (Note)
⊕	Protective Grounding (Inside and outside of the terminal box)

F12.ai

Note: Read "Functions" for the input/output signal of I/O terminals.

For sizes from 25 to 400 mm (1 to 16 in.), or AXW4A remote transmitter, read general specifications (GS 01E24A01-01EN).

For AXW4A FOUNDATION fieldbus type remote transmitter, read general specifications (GS 01E21F02-01E).

For AXW4A PROFIBUS PA type remote transmitter, read general specifications (GS 01E21F02-03EN).

For AXG1A remote transmitter, read general specifications (GS 01E22C01-01EN).

For AXFA11G remote transmitter, read general specifications (GS 01E20C01-01E).

Recommended Cable for Excitation, Power and Input/Output:

JIS C 3401 control cable equivalent

JIS C 3312 power cable equivalent

14 AWG Belden 8720 equivalent

Outer Diameter:

Without gland:

ø6.5 to ø12 mm (ø0.26 to ø0.47 in.)

With waterproof gland (optional code EG, EG#, EU, EU#, EW):

For excitation cable:

ø10.5 or ø11.5 mm (ø0.41 or ø0.45 in.)

For power and input/output cable:

ø7.5 to ø12 mm (ø0.30 to ø0.47 in.)

With plastic gland (optional code EP, EP#):

ø6 to ø12 mm (ø0.24 to ø0.47 in.)

Nominal Cross Section:

Single wire: 0.5 to 2.5 mm²

Stranded wire: 0.5 to 1.5 mm²

Excitation Cable for Submersible Use and Optional Code DHC:

Heat resistant vinyl resin sheath cable

Outer diameter ø10.5 mm (ø0.41 in.)

DIMENSIONAL DRAWINGS

- Size: 500 to 1000 mm (20 to 40 in.)

Unit: mm (approx. in.)

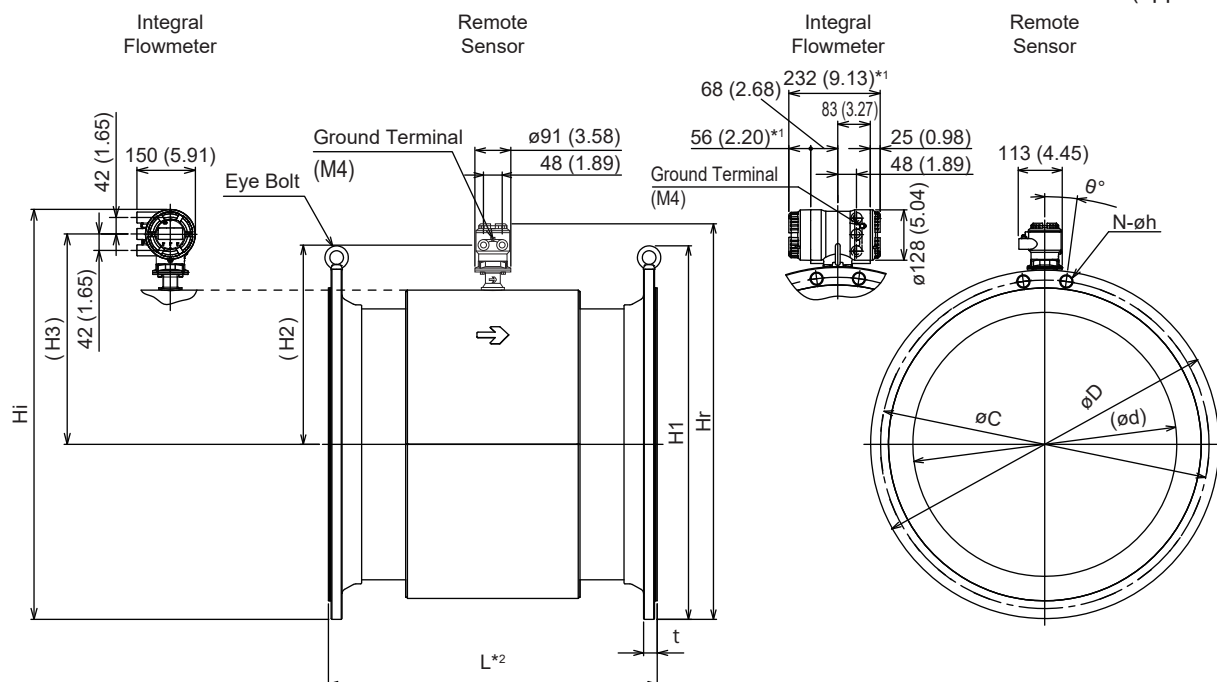

*1: This length becomes 21 mm (0.83 in.) shorter when indicator code N is selected.

F13.ai

*2: The thickness of optional grounding rings (4mm per one) and customer supplied gaskets are not included in "L" here.

○ ASME Flange (CA1)

Unit: mm (approx. in.)

Process Connection Code	CA1						
	ASME B16.5 Class150		ASME B16.47 Class150				
Flange Type							
Size Code	500	600	700	800	900	10L	
Size	500 (20)	600 (24)	700 (28)	800 (32)	900 (36)	1000 (40)	
Lining Code	H, F, U, D						
Lay Length L	600 (23.62)	720 (28.35)	840 (33.07)	960 (37.80)	1080 (42.52)	1200 (47.24)	
Flange Outer Diameter øD	700 (27.56)	815 (32.09)	927 (36.50)	1060 (41.75)	1168 (46.00)	1289 (50.75)	
Flange Thickness (*1) (incl. lining flare)	Lining F	48 (1.90)	53 (2.09)	76 (3.01)	86 (3.39)	95 (3.76)	95 (3.76)
	Lining H, D	47 (1.84)	52 (2.03)	75 (2.94)	85 (3.33)	94 (3.70)	94 (3.70)
	Lining U	47 (1.86)	52 (2.05)	77 (3.05)	87 (3.43)	96 (3.80)	96 (3.80)
Bolt Circle Diameter øC	635 (25.00)	749.3 (29.50)	863.6 (34.00)	977.9 (38.50)	1086 (42.75)	1200 (47.25)	
Inner Diameter ød	Lining H, F, D	477 (18.78)	578 (22.76)	675 (26.57)	777 (30.59)	878 (34.57)	976 (38.43)
	Lining U	469 (18.46)	570 (22.44)	667 (26.26)	769 (30.28)	870 (34.25)	968 (38.11)
Bolt Hole Pitch Half Angle θ	9°	9°	6.4°	6.4°	5.6°	5°	
Bolt Hole Diameter øh	31.8 (1.25)	34.9 (1.37)	35.1 (1.38)	41.1 (1.62)	41.1 (1.62)	41.1 (1.62)	
Number of Bolt Holes N	20	20	28	28	32	36	
Height H1	760 (29.92)	875 (34.45)	998 (39.29)	1150 (45.28)	1278 (50.31)	1399 (55.08)	
Remote Sensor, Height H2	401 (15.80)	452 (17.80)	501 (19.73)	552 (21.74)	604 (23.77)	655 (25.78)	
Remote Sensor, Maximum Height Hr	805 (31.68)	913 (35.95)	1018 (40.09)	1136 (44.71)	1241 (48.87)	1353 (53.26)	
Inner Diameter of Eye Bolt	35 (1.38)	35 (1.38)	40 (1.57)	50 (1.97)	60 (2.36)	60 (2.36)	
Remote Sensor, Approx. Weight, Unit: kg (lb) (*2)	212 (467)	305 (672)	479 (1056)	680 (1499)	882 (1944)	1125 (2480)	
Integral Flowmeter, Height H3	438 (17.24)	489 (19.26)	538 (21.20)	590 (23.21)	641 (25.24)	692 (27.25)	
Integral Flowmeter, Maximum Height Hi	851 (33.50)	960 (37.78)	1065 (41.93)	1183 (46.56)	1288 (50.71)	1400 (55.11)	
Integral Flowmeter, Approx. Weight, Unit: kg (lb)	215 (474)	308 (679)	482 (1063)	683 (1506)	885 (1951)	1128 (2487)	
Grounding Rings (GR1) (*3)	+8 (+0.31)	+8 (+0.31)	+8 (+0.31)	+8 (+0.31)	+8 (+0.31)	+8 (+0.31)	

*1: The limit deviation of the flange thickness "t" is as follows.

- Size 500, 600 mm (20, 24 in.): +6/-2 mm (+0.24/-0.08 in.)
- Size 700 mm (28 in.): +8/-2 mm (+0.31/-0.08 in.)
- Size 800 to 1000 mm: (32 to 40 in.): +10/-2 mm (+0.39/-0.08 in.)

*2: When submersible type or optional code DHC is selected, waterproof glands with union joints and cables are attached. When the cable length is 30-meters, add 9.5 kg (20.9 lb) to the weight in the table.

*3: When selecting this optional grounding rings, the value which is the thickness of both ends is added to the lay length "L". When preparing gaskets by customer side, please make sure to add the gaskets thickness to the total lay length "L".

○ AWWA Flange (CB1)

Unit: mm (approx. in.)

Process Connection Code		CB1			
Flange Type		AWWA C207 Class D			
Size Code		700	800	900	10L
Size		700 (28)	800 (32)	900 (36)	1000 (40)
Lining Code		H, F, U, D			
Lay Length L		840 (33.07)	960 (37.80)	1080 (42.52)	1200 (47.24)
Flange Outer Diameter ϕ D		927 (36.50)	1060 (41.75)	1168 (46.00)	1289 (50.75)
Flange Thickness (*1) (incl. lining flare)	Lining F	32.4 (1.28)	35.6 (1.40)	35.6 (1.40)	39 (1.54)
	Lining H, D	30.9 (1.22)	34.1 (1.34)	34.1 (1.34)	37.5 (1.48)
	Lining U	31.4 (1.24)	34.6 (1.36)	34.6 (1.36)	38 (1.50)
Bolt Circle Diameter ϕ C		863.6 (34.00)	977.9 (38.50)	1086 (42.75)	1200 (47.25)
Inner Diameter ϕ d	Lining H, F, D	675 (26.57)	777 (30.59)	878 (34.57)	976 (38.43)
	Lining U	667 (26.26)	769 (30.28)	870 (34.25)	968 (38.11)
Bolt Hole Pitch Half Angle θ		6.4°	6.4°	5.6°	5°
Bolt Hole Diameter ϕ h		34.9 (1.375)	41.3 (1.625)	41.3 (1.625)	41.3 (1.625)
Number of Bolt Holes N		28	28	32	36
Height H1		987 (38.86)	1131 (44.53)	1239 (48.78)	1379 (54.29)
Remote Sensor, Height H2		501 (19.73)	552 (21.74)	604 (23.77)	655 (25.78)
Remote Sensor, Maximum Height Hr		1018 (40.09)	1136 (44.71)	1241 (48.87)	1353 (53.26)
Inner Diameter of Eye Bolt		35 (1.38)	40 (1.57)	40 (1.57)	50 (1.97)
Remote Sensor, Approx. Weight, Unit: kg (lb) (*2)		288 (635)	387 (853)	485 (1069)	659 (1453)
Integral Flowmeter, Height H3		538 (21.20)	590 (23.21)	641 (25.24)	692 (27.25)
Integral Flowmeter, Maximum Height Hi		1065 (41.93)	1183 (46.56)	1288 (50.71)	1400 (55.11)
Integral Flowmeter, Approx. Weight, Unit: kg (lb)		291 (642)	390 (860)	488 (1076)	662 (1459)
Grounding Rings (GR1) (*3)		+8 (+0.31)	+8 (+0.31)	+8 (+0.31)	+8 (+0.31)

*1: The limit deviation of the flange thickness "t" is as follows.

• Size 700 to 1000 mm (28 to 40 in.): +6/-2 mm (+0.24/-0.08 in.)

*2: When submersible type or optional code DHC is selected, waterproof glands with union joints and cables are attached. When the cable length is 30-meters, add 9.5 kg (20.9 lb) to the weight in the table.

*3: When selecting this optional grounding rings, the value which is the thickness of both ends is added to the lay length "L". When preparing gaskets by customer side, please make sure to add the gaskets thickness to the total lay length "L".

○ EN PN10 Flange (fluid pressure up to 1 MPa) (CE1)

Unit: mm (approx. in.)

Process Connection Code		CE1					
Flange Type		EN1092-1 PN10					
Size Code		500	600	700	800	900	10L
Size		500 (20)	600 (24)	700 (28)	800 (32)	900 (36)	1000 (40)
Lining Code		H, F, U, D					
Lay Length L		600 (23.62)	720 (28.35)	840 (33.07)	960 (37.80)	1080 (42.52)	1200 (47.24)
Flange Outer Diameter ϕ D		670 (26.38)	780 (30.71)	895 (35.24)	1015 (39.96)	1115 (43.90)	1230 (48.43)
Flange Thickness (*1) (incl. lining flare)	Lining F	33 (1.30)	33 (1.30)	35 (1.38)	37 (1.46)	39 (1.54)	39 (1.54)
	Lining H, D	31.5 (1.24)	31.5 (1.24)	33.5 (1.32)	35.5 (1.4)	37.5 (1.48)	37.5 (1.48)
	Lining U	34 (1.34)	34 (1.34)	36 (1.42)	38 (1.50)	40 (1.57)	40 (1.57)
Bolt Circle Diameter ϕ C		620 (24.41)	725 (28.54)	840 (33.07)	950 (37.40)	1050 (41.34)	1160 (45.67)
Inner Diameter ϕ d	Lining H, F, D	477 (18.78)	578 (22.76)	675 (26.57)	777 (30.59)	878 (34.57)	976 (38.43)
	Lining U	469 (18.46)	570 (22.44)	667 (26.26)	769 (30.28)	870 (34.25)	968 (38.11)
Bolt Hole Pitch Half Angle θ		9°	9°	7.5°	7.5°	6.4°	6.4°
Bolt Hole Diameter ϕ h		26 (1.02)	30 (1.18)	30 (1.18)	33 (1.30)	33 (1.30)	36 (1.42)
Number of Bolt Holes N		20	20	24	24	28	28
Height H1		730 (28.74)	840 (33.07)	955 (37.60)	1086 (42.76)	1186 (46.69)	1320 (51.97)
Remote Sensor, Height H2		401 (15.80)	452 (17.80)	501 (19.73)	552 (21.74)	604 (23.77)	655 (25.78)
Remote Sensor, Maximum Height Hr		790 (31.09)	896 (35.26)	1002 (39.46)	1113 (43.83)	1215 (47.82)	1323 (52.09)
Inner Diameter of Eye Bolt		35 (1.38)	35 (1.38)	35 (1.38)	40 (1.57)	40 (1.57)	50 (1.97)
Remote Sensor, Approx. Weight, Unit: kg (lb) (*2)		170 (375)	232 (511)	285 (628)	380 (838)	491 (1082)	646 (1424)
Integral Flowmeter, Height H3		438 (17.24)	489 (19.26)	538 (21.20)	590 (23.21)	641 (25.24)	692 (27.25)
Integral Flowmeter, Maximum Height Hi		836 (32.91)	942 (37.09)	1049 (41.30)	1160 (45.67)	1262 (49.67)	1370 (53.94)
Integral Flowmeter, Approx. Weight, Unit: kg (lb)		173 (381)	235 (518)	288 (635)	383 (844)	494 (1089)	649 (1431)
Grounding Rings (GR1) (*3)		+8 (+0.31)	+8 (+0.31)	+8 (+0.31)	+8 (+0.31)	+8 (+0.31)	+8 (+0.31)

*1: The limit deviation of the flange thickness "t" is as follows.

• Size 500 to 1000 mm (20 to 40 in.): +3/-2 mm (+0.12/-0.08 in.)

*2: When submersible type or optional code DHC is selected, waterproof glands with union joints and cables are attached. When the cable length is 30-meters, add 9.5 kg (20.9 lb) to the weight in the table.

*3: When selecting this optional grounding rings, the value which is the thickness of both ends is added to the lay length "L". When preparing gaskets by customer side, please make sure to add the gaskets thickness to the total lay length "L".

○ EN PN16 Flange (fluid pressure up to 1 MPa) (CE2)

Unit: mm (approx. in.)

Process Connection Code		CE2					
Flange Type		EN1092-1 PN16					
Size Code		500	600	700	800	900	10L
Size		500 (20)	600 (24)	700 (28)	800 (32)	900 (36)	1000 (40)
Lining Code		H, F, U, D					
Lay Length L		600 (23.62)	720 (28.35)	840 (33.07)	960 (37.80)	1080 (42.52)	1200 (47.24)
Flange Outer Diameter ϕ D		715 (28.15)	840 (33.07)	910 (35.83)	1025 (40.35)	1125 (44.29)	1255 (49.41)
Flange Thickness (*1) (incl. lining flare)	Lining F	49 (1.93)	59 (2.32)	41 (1.61)	43 (1.69)	45 (1.77)	47 (1.85)
	Lining H, D	47.5 (1.87)	57.5 (2.26)	39.5 (1.56)	41.5 (1.63)	43.5 (1.71)	45.5 (1.79)
	Lining U	50 (1.97)	60 (2.36)	42 (1.65)	44 (1.73)	46 (1.81)	48 (1.89)
Bolt Circle Diameter ϕ C		650 (25.59)	770 (30.31)	840 (33.07)	950 (37.40)	1050 (41.34)	1170 (46.06)
Inner Diameter ϕ d	Lining H, F, D	477 (18.78)	578 (22.76)	675 (26.57)	777 (30.59)	878 (34.57)	976 (38.43)
	Lining U	469 (18.46)	570 (22.44)	667 (26.26)	769 (30.28)	870 (34.25)	968 (38.11)
Bolt Hole Pitch Half Angle θ		9°	9°	7.5°	7.5°	6.4°	6.4°
Bolt Hole Diameter ϕ h		33 (1.30)	36 (1.42)	36 (1.42)	39 (1.54)	39 (1.54)	42 (1.65)
Number of Bolt Holes N		20	20	24	24	28	28
Height H1		775 (30.51)	900 (35.43)	970 (38.19)	1096 (43.15)	1196 (47.09)	1345 (52.95)
Remote Sensor, Height H2		401 (15.80)	452 (17.80)	501 (19.73)	552 (21.74)	604 (23.77)	655 (25.78)
Remote Sensor, Maximum Height Hr		812 (31.98)	926 (36.44)	1010 (39.75)	1118 (44.02)	1220 (48.02)	1336 (52.59)
Inner Diameter of Eye Bolt		35 (1.38)	35 (1.38)	35 (1.38)	40 (1.57)	40 (1.57)	50 (1.97)
Remote Sensor, Approx. Weight, Unit: kg (lb) (*2)		230 (507)	350 (772)	330 (728)	427 (941)	535 (1179)	742 (1636)
Integral Flowmeter, Height H3		438 (17.24)	489 (19.26)	538 (21.20)	590 (23.21)	641 (25.24)	692 (27.25)
Integral Flowmeter, Maximum Height Hi		859 (33.80)	972 (38.28)	1056 (41.59)	1165 (45.87)	1267 (49.87)	1383 (54.44)
Integral Flowmeter, Approx. Weight, Unit: kg (lb)		233 (514)	353 (778)	333 (734)	430 (948)	538 (1186)	745 (1642)
Grounding Rings (GR1) (*3)		+8 (+0.31)	+8 (+0.31)	+8 (+0.31)	+8 (+0.31)	+8 (+0.31)	+8 (+0.31)

*1: The limit deviation of the flange thickness "t" is as follows.

• Size 500 to 1000 mm (20 to 40 in.): +3/-2 mm (+0.12/-0.08 in.)

*2: When submersible type or optional code DHC is selected, waterproof glands with union joints and cables are attached. When the cable length is 30-meters, add 9.5 kg (20.9 lb) to the weight in the table.

*3: When selecting this optional grounding rings, the value which is the thickness of both ends is added to the lay length "L".
When preparing gaskets by customer side, please make sure to add the gaskets thickness to the total lay length "L".

○ JIS 10K Flange (CJ1)

Unit: mm (approx. in.)

Process Connection Code		CJ1					
Flange Type		JIS B2220 10K					
Size Code		500	600	700	800	900	10L
Size		500 (20)	600 (24)	700 (28)	800 (32)	900 (36)	1000 (40)
Lining Code		H, F, U, D					
Lay Length L		600 (23.62)	720 (28.35)	840 (33.07)	960 (37.80)	1080 (42.52)	1200 (47.24)
Flange Outer Diameter ϕ D		675 (26.57)	795 (31.30)	905 (35.63)	1020 (40.16)	1120 (44.09)	1235 (48.62)
Flange Thickness (*1) (incl. lining flare)	Lining F	35 (1.38)	37 (1.46)	39 (1.54)	41 (1.61)	43 (1.69)	45 (1.77)
	Lining H, D	33.5 (1.32)	35.5 (1.40)	37.5 (1.48)	39.5 (1.56)	41.5 (1.63)	43.5 (1.71)
	Lining U	36 (1.42)	38 (1.50)	40 (1.57)	42 (1.65)	44 (1.73)	46 (1.81)
Bolt Circle Diameter ϕ C		620 (24.41)	730 (28.74)	840 (33.07)	950 (37.40)	1050 (41.34)	1160 (45.67)
Inner Diameter ϕ d	Lining H, F, D	477 (18.78)	578 (22.76)	675 (26.57)	777 (30.59)	878 (34.57)	976 (38.43)
	Lining U	469 (18.46)	570 (22.44)	667 (26.26)	769 (30.28)	870 (34.25)	968 (38.11)
Bolt Hole Pitch Half Angle θ		9°	7.5°	7.5°	6.4°	6.4°	6.4°
Bolt Hole Diameter ϕ h		27 (1.06)	33 (1.30)	33 (1.30)	33 (1.30)	33 (1.30)	39 (1.54)
Number of Bolt Holes N		20	24	24	28	28	28
Height H1		735 (28.94)	855 (33.66)	965 (37.99)	1091 (42.95)	1191 (46.89)	1325 (52.17)
Remote Sensor, Height H2		401 (15.80)	452 (17.80)	501 (19.73)	552 (21.74)	604 (23.77)	655 (25.78)
Remote Sensor, Maximum Height Hr		792 (31.19)	903 (35.56)	1007 (39.65)	1116 (43.93)	1217 (47.92)	1326 (52.19)
Inner Diameter of Eye Bolt		35 (1.38)	35 (1.38)	35 (1.38)	40 (1.57)	40 (1.57)	50 (1.97)
Remote Sensor, Approx. Weight, Unit: kg (lb) (*2)		156 (344)	223 (492)	310 (683)	408 (899)	522 (1151)	689 (1519)
Integral Flowmeter, Height H3		438 (17.24)	489 (19.26)	538 (21.20)	590 (23.21)	641 (25.24)	692 (27.25)
Integral Flowmeter, Maximum Height Hi		839 (33.01)	950 (37.39)	1054 (41.49)	1163 (45.77)	1264 (49.77)	1373 (54.04)
Integral Flowmeter, Approx. Weight, Unit: kg (lb)		159 (351)	226 (498)	313 (690)	411 (906)	525 (1157)	692 (1526)
Grounding Rings (GR1) (*3)		+8 (+0.31)	+8 (+0.31)	+8 (+0.31)	+8 (+0.31)	+8 (+0.31)	+8 (+0.31)

*1: The limit deviation of the flange thickness "t" is as follows.

• Size 500 to 1000 mm (20 to 40 in.): +3/-2 mm (+0.12/-0.08 in.)

*2: When submersible type or optional code DHC is selected, waterproof glands with union joints and cables are attached. When the cable length is 30-meters, add 9.5 kg (20.9 lb) to the weight in the table.

*3: When selecting this optional grounding rings, the value which is the thickness of both ends is added to the lay length "L".
When preparing gaskets by customer side, please make sure to add the gaskets thickness to the total lay length "L".

○ AS2129 Table D Flange (CS1)

Unit: mm (approx. in.)

Process Connection Code		CS1					
Flange Type		AS2129 Table D					
Size Code		500	600	700	800	900	10L
Size		500 (20)	600 (24)	700 (28)	800 (32)	900 (36)	1000 (40)
Lining Code		H, F, U, D					
Lay Length L		600 (23.62)	720 (28.35)	840 (33.07)	960 (37.80)	1080 (42.52)	1200 (47.24)
Flange Outer Diameter ϕ D		705 (27.76)	825 (32.48)	910 (35.83)	1060 (41.73)	1175 (46.26)	1255 (49.41)
Flange Thickness (*1) (incl. lining flare)	Lining F	34 (1.34)	37 (1.46)	40 (1.57)	46 (1.81)	53 (2.09)	56 (2.20)
	Lining H, D	32.5 (1.28)	35.5 (1.40)	38.5 (1.52)	44.5 (1.75)	51.5 (2.03)	54.5 (2.15)
	Lining U	35 (1.38)	38 (1.50)	41 (1.61)	47 (1.85)	54 (2.13)	57 (2.24)
Bolt Circle Diameter ϕ C		641 (25.24)	756 (29.76)	845 (33.27)	984 (38.74)	1092 (42.99)	1175 (46.26)
Inner Diameter ϕ d	Lining H, F, D	477 (18.78)	578 (22.76)	675 (26.57)	777 (30.59)	878 (34.57)	976 (38.43)
	Lining U	469 (18.46)	570 (22.44)	667 (26.26)	769 (30.28)	870 (34.25)	968 (38.11)
Bolt Hole Pitch Half Angle θ		11.3°	11.3°	9°	9°	7.5°	7.5°
Bolt Hole Diameter ϕ h		26 (1.02)	30 (1.18)	30 (1.18)	36 (1.42)	36 (1.42)	36 (1.42)
Number of Bolt Holes N		16	16	20	20	24	24
Height H1		765 (30.12)	885 (34.84)	970 (38.19)	1131 (44.53)	1265 (49.80)	1345 (52.95)
Remote Sensor, Height H2		401 (15.80)	452 (17.80)	501 (19.73)	552 (21.74)	604 (23.77)	655 (25.78)
Remote Sensor, Maximum Height Hr		807 (31.78)	918 (36.15)	1010 (39.75)	1136 (44.71)	1245 (49.00)	1336 (52.59)
Inner Diameter of Eye Bolt		35 (1.38)	35 (1.38)	35 (1.38)	40 (1.57)	50 (1.97)	50 (1.97)
Remote Sensor, Approx. Weight, Unit: kg (lb) (*2)		157 (346)	225 (496)	290 (639)	433 (977)	594 (1310)	728 (1605)
Integral Flowmeter, Height H3		438 (17.24)	489 (19.26)	538 (21.20)	590 (23.21)	641 (25.24)	692 (27.25)
Integral Flowmeter, Maximum Height Hi		854 (33.60)	965 (37.98)	1056 (41.59)	1183 (46.56)	1292 (50.85)	1383 (54.44)
Integral Flowmeter, Approx. Weight, Unit: kg (lb)		160 (353)	228 (503)	293 (646)	436 (961)	597 (1316)	731 (1612)
Grounding Rings (GR1) (*3)		+8 (+0.31)	+8 (+0.31)	+8 (+0.31)	+8 (+0.31)	+8 (+0.31)	+8 (+0.31)

*1: The limit deviation of the flange thickness "t" is as follows.

• Size 500 to 1000 mm (20 to 40 in.): +4/-2 mm (+0.16/-0.08 in.)

*2: When submersible type or optional code DHC is selected, waterproof glands with union joints and cables are attached. When the cable length is 30-meters, add 9.5 kg (20.9 lb) to the weight in the table.

*3: When selecting this optional grounding rings, the value which is the thickness of both ends is added to the lay length "L".
When preparing gaskets by customer side, please make sure to add the gaskets thickness to the total lay length "L".

○ AS2129 Table E Flange (CS2)

Unit: mm (approx. in.)

Process Connection Code		CS2					
Flange Type		AS2129 Table E					
Size Code		500	600	700	800	900	10L
Size		500 (20)	600 (24)	700 (28)	800 (32)	900 (36)	1000 (40)
Lining Code		H, F, U, D					
Lay Length L		600 (23.62)	720 (28.35)	840 (33.07)	960 (37.80)	1080 (42.52)	1200 (47.24)
Flange Outer Diameter ϕ D		705 (27.76)	825 (32.48)	910 (35.83)	1060 (41.73)	1175 (46.26)	1255 (49.41)
Flange Thickness (*1) (incl. lining flare)	Lining F	43 (1.69)	53 (2.09)	56 (2.20)	59 (2.32)	69 (2.72)	72 (2.83)
	Lining H, D	41.5 (1.63)	51.5 (2.03)	54.5 (2.15)	57.5 (2.26)	67.5 (2.66)	70.5 (2.78)
	Lining U	44 (1.73)	54 (2.13)	57 (2.24)	60 (2.36)	70 (2.76)	73 (2.87)
Bolt Circle Diameter ϕ C		641 (25.24)	756 (29.76)	845 (33.27)	984 (38.74)	1092 (42.99)	1175 (45.67)
Inner Diameter ϕ d	Lining H, F, D	477 (18.78)	578 (22.76)	675 (26.57)	777 (30.59)	878 (34.57)	976 (38.43)
	Lining U	469 (18.46)	570 (22.44)	667 (26.26)	769 (30.28)	870 (34.25)	968 (38.11)
Bolt Hole Pitch Half Angle θ		11.3°	11.3°	9°	9°	7.5°	7.5°
Bolt Hole Diameter ϕ h		26 (1.02)	33 (1.30)	33 (1.30)	36 (1.42)	36 (1.42)	39 (1.54)
Number of Bolt Holes N		16	16	20	20	24	24
Height H1		765 (30.12)	885 (34.84)	970 (38.19)	1131 (44.53)	1265 (49.80)	1345 (52.95)
Remote Sensor, Height H2		401 (15.80)	452 (17.80)	501 (19.73)	552 (21.74)	604 (23.77)	655 (25.78)
Remote Sensor, Maximum Height Hr		807 (31.78)	918 (36.15)	1010 (39.75)	1136 (44.71)	1245 (49.00)	1336 (52.59)
Inner Diameter of Eye Bolt		35 (1.38)	35 (1.38)	35 (1.38)	40 (1.57)	50 (1.97)	50 (1.97)
Remote Sensor, Approx. Weight, Unit: kg (lb) (*2)		184 (406)	288 (635)	354 (780)	508 (1120)	703 (1550)	832 (1834)
Integral Flowmeter, Height H3		438 (17.24)	489 (19.26)	538 (21.20)	590 (23.21)	641 (25.24)	692 (27.25)
Integral Flowmeter, Maximum Height Hi		854 (33.60)	965 (37.98)	1056 (41.59)	1183 (46.56)	1292 (50.85)	1383 (54.44)
Integral Flowmeter, Approx. Weight, Unit: kg (lb)		187 (412)	291 (642)	357 (787)	511 (1127)	706 (1556)	835 (1841)
Grounding Rings (GR1) (*3)		+8 (+0.31)	+8 (+0.31)	+8 (+0.31)	+8 (+0.31)	+8 (+0.31)	+8 (+0.31)

*1: The limit deviation of the flange thickness "t" is as follows.

• Size 500 to 1000 mm (20 to 40 in.): +4/-2 mm (+0.16/-0.08 in.)

*2: When submersible type or optional code DHC is selected, waterproof glands with union joints and cables are attached. When the cable length is 30-meters, add 9.5 kg (20.9 lb) to the weight in the table.

*3: When selecting this optional grounding rings, the value which is the thickness of both ends is added to the lay length "L".
When preparing gaskets by customer side, please make sure to add the gaskets thickness to the total lay length "L".

○ AS4087 PN16 Flange (CT1)

Unit: mm (approx. in.)

Process Connection Code	CT1						
Flange Type	AS4087 PN16						
Size Code	500	600	700	800	900	10L	
Size	500 (20)	600 (24)	700 (28)	800 (32)	900 (36)	1000 (40)	
Lining Code	H, F, U, D						
Lay Length L	600 (23.62)	720 (28.35)	840 (33.07)	960 (37.80)	1080 (42.52)	1200 (47.24)	
Flange Outer Diameter ϕ D	705 (27.76)	825 (32.48)	910 (35.83)	1060 (41.73)	1175 (46.26)	1255 (49.41)	
Flange Thickness (*1) (incl. lining flare)	Lining F	43 (1.69)	53 (2.09)	61 (2.40)	61 (2.40)	71 (2.80)	71 (2.80)
	Lining H, D	41.5 (1.63)	51.5 (2.03)	59.5 (2.34)	59.5 (2.34)	69.5 (2.74)	69.5 (2.74)
	Lining U	44 (1.73)	54 (2.13)	62 (2.44)	62 (2.44)	72 (2.83)	72 (2.83)
Bolt Circle Diameter ϕ C	641 (25.24)	756 (29.76)	845 (33.27)	984 (38.74)	1092 (42.99)	1175 (45.67)	
Inner Diameter ϕ d	Lining H, F, D	477 (18.78)	578 (22.76)	675 (26.57)	777 (30.59)	878 (34.57)	976 (38.43)
	Lining U	469 (18.46)	570 (22.44)	667 (26.26)	769 (30.28)	870 (34.25)	968 (38.11)
Bolt Hole Pitch Half Angle θ	11.3°	11.3°	9°	9°	7.5°	7.5°	
Bolt Hole Diameter ϕ h	26 (1.02)	30 (1.18)	30 (1.18)	36 (1.42)	36 (1.42)	36 (1.42)	
Number of Bolt Holes N	16	16	20	20	24	24	
Height H1	765 (30.12)	885 (34.84)	970 (38.19)	1131 (44.53)	1265 (49.80)	1345 (52.95)	
Remote Sensor, Height H2	401 (15.80)	452 (17.80)	501 (19.73)	552 (21.74)	604 (23.77)	655 (25.78)	
Remote Sensor, Maximum Height Hr	807 (31.78)	918 (36.15)	1010 (39.75)	1136 (44.71)	1245 (49.00)	1336 (52.59)	
Inner Diameter of Eye Bolt	35 (1.38)	35 (1.38)	35 (1.38)	40 (1.57)	50 (1.97)	50 (1.97)	
Remote Sensor, Approx. Weight, Unit: kg (lb) (*2)	184 (406)	288 (635)	374 (825)	520 (1146)	716 (1579)	826 (1821)	
Integral Flowmeter, Height H3	438 (17.24)	489 (19.26)	538 (21.20)	590 (23.21)	641 (25.24)	692 (27.25)	
Integral Flowmeter, Maximum Height Hi	854 (33.60)	965 (37.98)	1056 (41.59)	1183 (46.56)	1292 (50.85)	1383 (54.44)	
Integral Flowmeter, Approx. Weight, Unit: kg (lb)	187 (412)	291 (642)	377 (831)	523 (1153)	719 (1585)	829 (1828)	
Grounding Rings (GR1) (*3)	+8 (+0.31)	+8 (+0.31)	+8 (+0.31)	+8 (+0.31)	+8 (+0.31)	+8 (+0.31)	

*1: The limit deviation of the flange thickness "t" is as follows.

• Size 500 to 1000 mm (20 to 40 in.): +4/-2 mm (+0.16/-0.08 in.)

*2: When submersible type or optional code DHC is selected, waterproof glands with union joints and cables are attached. When the cable length is 30-meters, add 9.5 kg (20.9 lb) to the weight in the table.

*3: When selecting this optional grounding rings, the value which is the thickness of both ends is added to the lay length "L".
When preparing gaskets by customer side, please make sure to add the gaskets thickness to the total lay length "L".

○ JIS F12 Flange (CG1)

Unit: mm (approx. in.)

Process Connection Code	CG1						
Flange Type	JIS G3443-2 F12						
Size Code	500	600	700	800	900	10L	
Size	500 (20)	600 (24)	700 (28)	800 (32)	900 (36)	1000 (40)	
Lining Code	U						
Lay Length L	600 (23.62)	720 (28.35)	840 (33.07)	960 (37.80)	1080 (42.52)	1200 (47.24)	
Flange Outer Diameter ϕ D	706 (27.80)	810 (31.89)	928 (36.54)	1034 (40.71)	1156 (45.51)	1262 (49.69)	
Flange Thickness (*1) (incl. lining flare)	Lining U	34 (1.34)	36 (1.42)	38 (1.50)	40 (1.57)	42 (1.65)	44 (1.73)
Bolt Circle Diameter ϕ C	639 (25.16)	743 (29.25)	854 (33.62)	960 (37.80)	1073 (42.24)	1179 (46.42)	
Inner Diameter ϕ d	Lining U	469 (18.46)	570 (22.44)	667 (26.26)	769 (30.28)	870 (34.25)	968 (38.11)
Bolt Hole Pitch Half Angle θ	15°	11.3°	11.3°	9°	9°	7.5°	
Bolt Hole Diameter ϕ h	27 (1.06)	27 (1.06)	33 (1.30)	33 (1.30)	33 (1.30)	33 (1.30)	
Number of Bolt Holes N	12	16	16	20	20	24	
Height H1	766 (30.16)	870 (34.25)	988 (38.90)	1105 (43.50)	1227 (48.31)	1352 (53.23)	
Remote Sensor, Height H2	401 (15.80)	452 (17.80)	501 (19.73)	552 (21.74)	604 (23.77)	655 (25.78)	
Remote Sensor, Maximum Height Hr	808 (31.80)	911 (35.85)	1019 (40.11)	1123 (44.20)	1235 (48.63)	1339 (52.72)	
Inner Diameter of Eye Bolt	35 (1.38)	35 (1.38)	35 (1.38)	40 (1.57)	40 (1.57)	50 (1.97)	
Remote Sensor, Approx. Weight, Unit: kg (lb) (*2)	168 (370)	228 (503)	319 (703)	404 (891)	540 (1190)	703 (1550)	
Integral Flowmeter, Height H3	438 (17.24)	489 (19.26)	538 (21.20)	590 (23.21)	641 (25.24)	692 (27.25)	
Integral Flowmeter, Maximum Height Hi	854 (33.62)	957 (37.69)	1065 (41.94)	1170 (46.04)	1282 (50.48)	1386 (54.57)	
Integral Flowmeter, Approx. Weight, Unit: kg (lb)	171 (377)	231 (509)	322 (710)	407 (897)	543 (1197)	706 (1556)	
Grounding Rings (GR1) (*3)	+8 (+0.31)	+8 (+0.31)	+8 (+0.31)	+8 (+0.31)	+8 (+0.31)	+8 (+0.31)	

*1: The limit deviation of the flange thickness "t" is as follows.

• Size 500 to 1000 mm (20 to 40 in.): +3/-0 mm (+0.12/-0 in.)

*2: When submersible type or optional code DHC is selected, waterproof glands with union joints and cables are attached. When the cable length is 30-meters, add 9.5 kg (20.9 lb) to the weight in the table.

*3: When selecting this optional grounding rings, the value which is the thickness of both ends is added to the lay length "L".
When preparing gaskets by customer side, please make sure to add the gaskets thickness to the total lay length "L".

● Grounding Ring (Optional Code GR1) for size 500 to 1000 mm (20 to 40 in.)

Unit: mm (approx. in.)

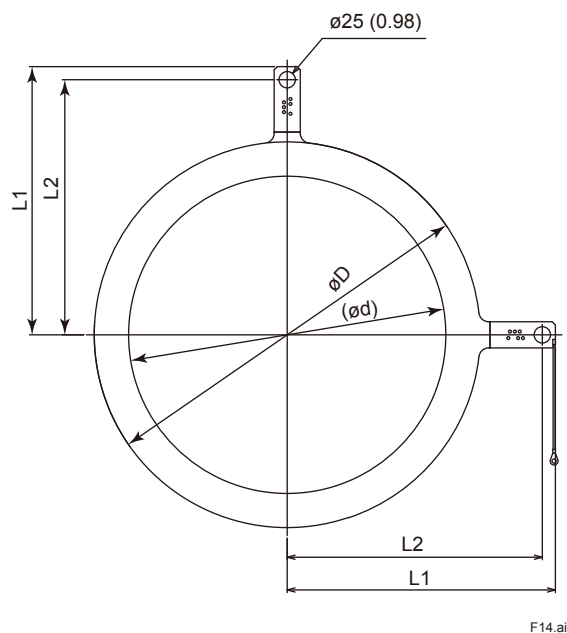

Unit: mm (approx. in.)

Process Connection Code	CA1, CB1, CE1, CE2, CJ1, CS1, CS2, CT1, CG1					
Size Code	500	600	700	800	900	10L
Size	500 (20)	600 (24)	700 (28)	800 (32)	900 (36)	1000 (40)
Lining Code	H, F, U, D					
Ring Outer Diameter øD	590 (23.23)	690 (27.17)	799 (31.46)	906 (35.67)	1006 (39.61)	1116 (43.94)
Ring Inner Diameter ød	485 (19.09)	586 (23.07)	683 (26.89)	787 (30.98)	888 (34.96)	986 (38.82)
Length L1	410 (16.14)	477.5 (18.80)	517.5 (20.37)	586 (23.07)	640 (25.20)	697.5 (27.46)
Length L2	390 (15.35)	457.5 (18.01)	497.5 (19.59)	566 (22.28)	620 (24.41)	677.5 (26.67)
Thickness	4 (0.16)					
Approx. Weight, Unit: kg (lb)	3.1 (6.8)	3.7 (8.1)	4.6 (10.2)	5.4 (12.0)	6.0 (13.3)	7.3 (16.1)

- Size: 1100 to 1800 mm (44 to 72 in.)

Remote Sensor

Unit: mm (approx. inch)

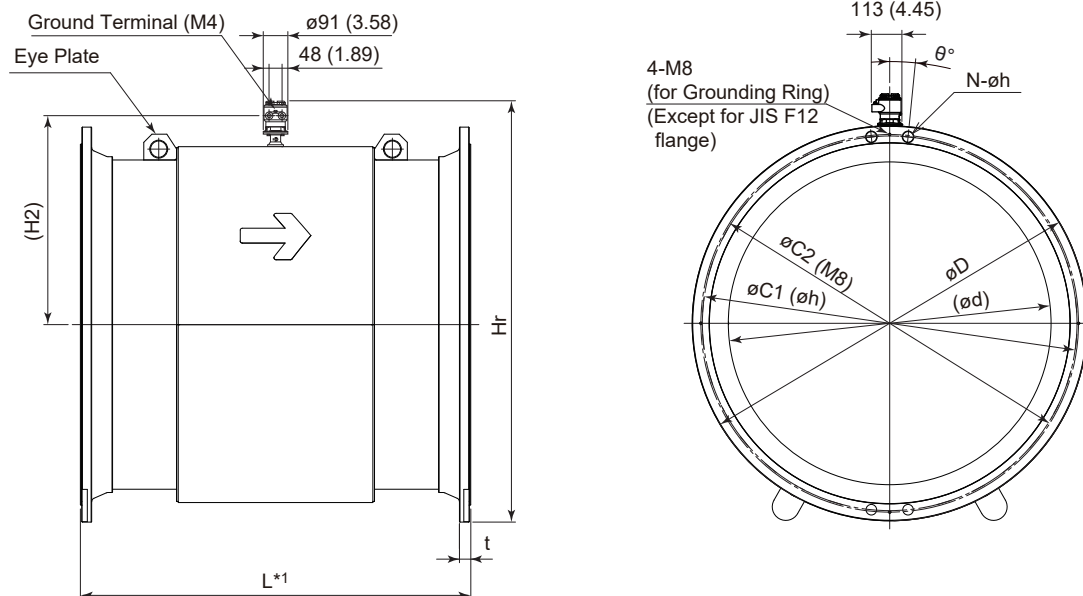

- *1: The thickness of optional grounding rings (5 mm for optional code GR1, and 25 mm for optional code GR2 per one (including integrated gasket)) and customer supplied gaskets are not included in "L" here.

○ AWWA Flange (CB1)

Unit: mm (approx. in.)

Process Connection Code	CB1	
Flange Type	AWWA C207 Class D	
Size Code	12L	
Size	1200 (48)	
Lining Code	H	
Lay Length L	1440 (56.69)	
Flange Outer Diameter ϕD	1511.3 (59.50)	
Flange Thickness (*1) (incl. lining flare)	Lining H	40.4 (1.59)
Flange Bolt Circle Diameter $\phi C1$	1422.4 (56.00)	
Ring Bolt Circle Diameter $\phi C2$	1426 (56.14)	
Inner Diameter ϕd	Lining H	1189 (46.81)
Bolt Hole Pitch Half Angle θ	4.1°	
Bolt Hole Diameter ϕh	41.3 (1.625)	
Number of Bolt Holes N	44	
Remote Sensor, Height H2	763 (30.02)	
Remote Sensor, Maximum Height Hr	1572 (61.88)	
Inner Diameter of Eye Plate	60 (2.36)	
Remote Sensor, Approx. Weight, Unit: kg (lb) (*2)	930 (2050)	
Grounding Rings (GR1) (*3)	+10 (+0.39)	

- *1: The limit deviation of the flange thickness "t" is as follows.
 • Size 1200 mm (48 in.): +6/-0 mm (+0.24/-0 in.)
- *2: When submersible type or optional code DHC is selected, waterproof glands with union joints and cables are attached. When the cable length is 30-meters, add 9.5 kg (20.9 lb) to the weight in the table.
- *3: When selecting this optional grounding rings, the value which is the thickness of both ends is added to the lay length "L".
 When preparing gaskets by customer side, please make sure to add the gaskets thickness to the total lay length "L".

○ EN PN6 Flange (CEJ)

Unit: mm (approx. in.)

Process Connection Code		CEJ			
Flange Type		EN1092-1 PN6			
Size Code		12L	14L	16L	18L
Size		1200 (48)	1400 (56)	1600 (64)	1800 (72)
Lining Code		H			
Lay Length L		1440 (56.69)	1680 (66.14)	1920 (75.59)	2160 (85.04)
Flange Outer Diameter ϕ D		1405 (55.31)	1630 (64.17)	1830 (72.05)	2045 (80.51)
Flange Thickness (*1) (incl. lining flare)	Lining H	31.5 (1.24)	35.5 (1.40)	37.5 (1.48)	40.5 (1.59)
Flange Bolt Circle Diameter ϕ C1		1340 (52.76)	1560 (61.42)	1760 (69.29)	1970 (77.56)
Ring Bolt Circle Diameter ϕ C2		1356 (53.39)	1572 (61.89)	1772 (69.76)	1981 (77.99)
Inner Diameter ϕ d	Lining H	1195 (47.05)	1398 (55.04)	1586 (62.44)	1784 (70.24)
Bolt Hole Pitch Half Angle θ		5.6°	5°	4.5°	4.1°
Bolt Hole Diameter ϕ h		33 (1.30)	36 (1.42)	36 (1.42)	39 (1.54)
Number of Bolt Holes N		32	36	40	44
Remote Sensor, Height H2		763 (30.02)	865 (34.06)	961 (37.83)	1060 (41.73)
Remote Sensor, Maximum Height Hr		1519 (59.78)	1734 (68.25)	1930 (75.96)	2136 (84.09)
Inner Diameter of Eye Plate		60 (2.36)	70 (2.76)	70 (2.76)	80 (3.15)
Remote Sensor, Approx. Weight, Unit: kg (lb) (*2)		620 (1367)	920 (2028)	1310 (2888)	1670 (3682)
Grounding Rings (GR1) (*3)		+10 (+0.39)	+10 (+0.39)	+10 (+0.39)	+10 (+0.39)

*1: The limit deviation of the flange thickness "t" is as follows.

• Size 1200 to 1800 mm (48 to 72 in.): +3/-2 mm (+0.12/-0.08 in.)

*2: When submersible type or optional code DHC is selected, waterproof glands with union joints and cables are attached. When the cable length is 30-meters, add 9.5 kg (20.9 lb) to the weight in the table.

*3: When selecting this optional grounding rings, the value which is the thickness of both ends is added to the lay length "L".
When preparing gaskets by customer side, please make sure to add the gaskets thickness to the total lay length "L".

○ EN PN10 Flange (fluid pressure up to 0.6 MPa) (CEK)

Unit: mm (approx. in.)

Process Connection Code		CEK			
Flange Type		EN1092-1 PN10			
Size Code		12L	14L	16L	18L
Size		1200 (48)	1400 (56)	1600 (64)	1800 (72)
Lining Code		H			
Lay Length L		1440 (56.69)	1680 (66.14)	1920 (75.59)	2160 (85.04)
Flange Outer Diameter ϕ D		1455 (57.28)	1675 (65.94)	1915 (75.39)	2115 (83.27)
Flange Thickness (*1) (incl. lining flare)	Lining H	41.5 (1.63)	45.5 (1.79)	52.5 (2.07)	56.5 (2.22)
Flange Bolt Circle Diameter ϕ C1		1380 (54.33)	1590 (62.60)	1820 (71.65)	2020 (79.53)
Ring Bolt Circle Diameter ϕ C2		1391 (54.76)	1596 (62.83)	1822 (71.73)	2022 (79.61)
Inner Diameter ϕ d	Lining H	1195 (47.05)	1398 (55.04)	1586 (62.44)	1784 (70.24)
Bolt Hole Pitch Half Angle θ		5.6°	5°	4.5°	4.1°
Bolt Hole Diameter ϕ h		39 (1.54)	42 (1.65)	48 (1.89)	48 (1.89)
Number of Bolt Holes N		32	36	40	44
Remote Sensor, Height H2		763 (30.02)	865 (34.06)	961 (37.83)	1060 (41.73)
Remote Sensor, Maximum Height Hr		1544 (60.77)	1756 (69.13)	1972 (77.64)	2171 (85.47)
Inner Diameter of Eye Plate		60 (2.36)	70 (2.76)	70 (2.76)	80 (3.15)
Remote Sensor, Approx. Weight, Unit: kg (lb) (*2)		790 (1742)	1120 (2469)	1720 (3792)	2130 (4696)
Grounding Rings (GR1) (*3)		+10 (+0.39)	+10 (+0.39)	+10 (+0.39)	+10 (+0.39)

*1: The limit deviation of the flange thickness "t" is as follows.

• Size 1200 to 1800 mm (48 to 72 in.): +4/-3 mm (+0.16/-0.12 in.)

*2: When submersible type or optional code DHC is selected, waterproof glands with union joints and cables are attached. When the cable length is 30-meters, add 9.5 kg (20.9 lb) to the weight in the table.

*3: When selecting this optional grounding rings, the value which is the thickness of both ends is added to the lay length "L".
When preparing gaskets by customer side, please make sure to add the gaskets thickness to the total lay length "L".

○ EN PN10 Flange (fluid pressure up to 1 MPa) (CE1)

Unit: mm (approx. in.)

Process Connection Code		CE1			
Flange Type		EN1092-1 PN10			
Size Code		12L	14L	16L	18L
Size		1200 (48)	1400 (56)	1600 (64)	1800 (72)
Lining Code		H			
Lay Length L		1440 (56.69)	1680 (66.14)	1920 (75.59)	2160 (85.04)
Flange Outer Diameter ϕ D		1455 (57.28)	1675 (65.94)	1915 (75.39)	2115 (83.27)
Flange Thickness (*1) (incl. lining flare)	Lining H	41.5 (1.63)	45.5 (1.79)	52.5 (2.07)	56.5 (2.22)
Flange Bolt Circle Diameter ϕ C1		1380 (54.33)	1590 (62.60)	1820 (71.65)	2020 (79.53)
Ring Bolt Circle Diameter ϕ C2		1391 (54.76)	1596 (62.83)	1822 (71.73)	2022 (79.61)
Inner Diameter ϕ d	Lining H	1189 (46.81)	1390 (54.72)	1582 (62.28)	1776 (69.92)
Bolt Hole Pitch Half Angle θ		5.6°	5°	4.5°	4.1°
Bolt Hole Diameter ϕ h		39 (1.54)	42 (1.65)	48 (1.89)	48 (1.89)
Number of Bolt Holes N		32	36	40	44
Remote Sensor, Height H2		763 (30.02)	865 (34.06)	961 (37.83)	1060 (41.73)
Remote Sensor, Maximum Height Hr		1544 (60.77)	1756 (69.13)	1972 (77.64)	2171 (85.47)
Inner Diameter of Eye Plate		60 (2.36)	70 (2.76)	70 (2.76)	80 (3.15)
Remote Sensor, Approx. Weight, Unit: kg (lb) (*2)		920 (2028)	1340 (2954)	1860 (4101)	2510 (5534)
Grounding Rings (GR1) (*3)		+10 (+0.39)	+10 (+0.39)	+10 (+0.39)	+10 (+0.39)

*1: The limit deviation of the flange thickness "t" is as follows.

• Size 1200 to 1800 mm (48 to 72 in.): +4/-3 mm (+0.16/-0.12 in.)

*2: When submersible type or optional code DHC is selected, waterproof glands with union joints and cables are attached. When the cable length is 30-meters, add 9.5 kg (20.9 lb) to the weight in the table.

*3: When selecting this optional grounding rings, the value which is the thickness of both ends is added to the lay length "L".
When preparing gaskets by customer side, please make sure to add the gaskets thickness to the total lay length "L".

○ AS2129 Table D (CS1), Table E (CS2), AS4087 PN16 (CT1) Flange

Unit: mm (approx. in.)

Process Connection Code		CS1	CS2	CT1
Flange Type		AS2129 Table D	AS2129 Table E	AS4087 PN16
Size Code		12L		
Size		1200 (48)		
Lining Code		H		
Lay Length L		1440 (56.69)	1440 (56.69)	1440 (56.69)
Flange Outer Diameter ϕ D		1490 (58.66)	1490 (58.66)	1490 (58.66)
Flange Thickness (*1) (incl. lining flare)	Lining H	63.5 (2.50)	82.5 (3.25)	79.5 (3.13)
Flange Bolt Circle Diameter ϕ C1		1410 (55.51)	1410 (55.51)	1410 (55.51)
Ring Bolt Circle Diameter ϕ C2		1426 (56.14)	1426 (56.14)	1426 (56.14)
Inner Diameter ϕ d	Lining H	1189 (46.81)	1189 (46.81)	1189 (46.81)
Bolt Hole Pitch Half Angle θ		5.6°	5.6°	5.6°
Bolt Hole Diameter ϕ h		36 (1.42)	39 (1.54)	36 (1.42)
Number of Bolt Holes N		32	32	32
Remote Sensor, Height H2		763 (30.02)	763 (30.02)	763 (30.02)
Remote Sensor, Maximum Height Hr		1561 (61.46)	1561 (61.46)	1561 (61.46)
Inner Diameter of Eye Plate		60 (2.36)	60 (2.36)	60 (2.36)
Remote Sensor, Approx. Weight, Unit: kg (lb) (*2)		1050 (2315)	1210 (2668)	1180 (2601)
Grounding Rings (GR1) (*3)		+10 (+0.39)	+10 (+0.39)	+10 (+0.39)

*1: The limit deviation of the flange thickness "t" is as follows.

• Size 1200 mm (48 in.): +6/-0 mm (+0.24/-0 in.)

*2: When submersible type or optional code DHC is selected, waterproof glands with union joints and cables are attached. When the cable length is 30-meters, add 9.5 kg (20.9 lb) to the weight in the table.

*3: When selecting this optional grounding rings, the value which is the thickness of both ends is added to the lay length "L".
When preparing gaskets by customer side, please make sure to add the gaskets thickness to the total lay length "L".

○ JIS F12 Flange (CG1)

Unit: mm (approx. in.)

Process Connection Code		CG1					
Flange Type		JIS G3443-2 F12					
Size Code		11L	12L	13L	15L	16L	18L
Size		1100 (44)	1200 (48)	1350 (54)	1500 (60)	1600 (64)	1800 (72)
Lining Code		U					
Lay Length L		1320 (51.97)	1440 (56.69)	1620 (63.78)	1800 (70.87)	1920 (75.59)	2160 (85.04)
Flange Outer Diameter ϕD		1366 (53.78)	1470 (57.87)	1642 (64.65)	1800 (70.87)	1915 (75.39)	2115 (83.27)
Flange Thickness (*1) (incl. lining flare)	Lining U	49 (1.93)	51 (2.01)	53 (2.09)	56 (2.20)	63 (2.48)	65 (2.56)
Bolt Circle Diameter $\phi C1$		1283 (50.51)	1387 (54.61)	1552 (61.10)	1710 (67.32)	1820 (71.65)	2020 (79.53)
Grounding Ring Inner Diameter ϕd	Lining U	1071 (42.17)	1172 (46.14)	1322 (52.05)	1469 (57.83)	1565 (61.61)	1759 (69.25)
Bolt Hole Pitch Half Angle θ		7.5°	6.4°	6.4°	5.6°	5°	4.1°
Bolt Hole Diameter ϕh		33 (1.30)	33 (1.30)	39 (1.54)	39 (1.54)	39 (1.54)	39 (1.54)
Number of Bolt Holes N		24	28	28	32	36	44
Remote Sensor, Height H2		712 (28.03)	763 (30.02)	840 (33.05)	913 (35.94)	961 (37.83)	1060 (41.73)
Remote Sensor, Maximum Height Hr		1449 (57.03)	1551 (61.06)	1714 (67.48)	1867 (73.48)	1972 (77.64)	2171 (85.47)
Inner Diameter of Eye Plate		60 (2.36)	60 (2.36)	70 (2.76)	70 (2.76)	70 (2.76)	80 (3.15)
Remote Sensor, Approx. Weight, Unit: kg (lb) (*2)		910 (2006)	1060 (2337)	1430 (3153)	1770 (3902)	2090 (4608)	2890 (6371)
Grounding Rings (GR2) (*3)(*4)		+58 (+2.28)	+58 (+2.28)	+58 (+2.28)	+58 (+2.28)	+62 (+2.44)	+62 (+2.44)

*1: The limit deviation of the flange thickness "t" is as follows.

• Size 1100 to 1800 mm (44 to 72 in.): +5/-0 mm (+0.20/-0 in.)

*2: When submersible type or optional code DHC is selected, waterproof glands with union joints and cables are attached. When the cable length is 30-meters, add 9.5 kg (20.9 lb) to the weight in the table.

*3: The grounding rings (optional code GR2) are installed and locked onto the remote sensor with gaskets B when shipped from factory. Refer to "CAUTIONS ON SELECTION AND INSTALLATION". The GF type 1 gaskets by JIS G 3443-2 are used for the gaskets B.

*4: When selecting this optional grounding rings, the value which is the thickness of both ends is added to the lay length "L".

At the time of product shipment, the value (which is the thickness of both ends) is the total value obtained by adding the thickness of the grounding ring and the convexity (α) of the gasket as shown in the figure on the lower left.

Also when connecting the customer pipe flanges and the remote sensor, the grounding ring and the remote sensor are in close contact as shown in the figure on the lower right.

Therefore, the value (25 mm \times 2 = +50 mm) added to the lay length is the thickness of the ground ring only.

Refer to "Grounding Ring (Optional Code GR2)".

At the time of product shipment

When connecting the customer pipe flanges and the remote sensor

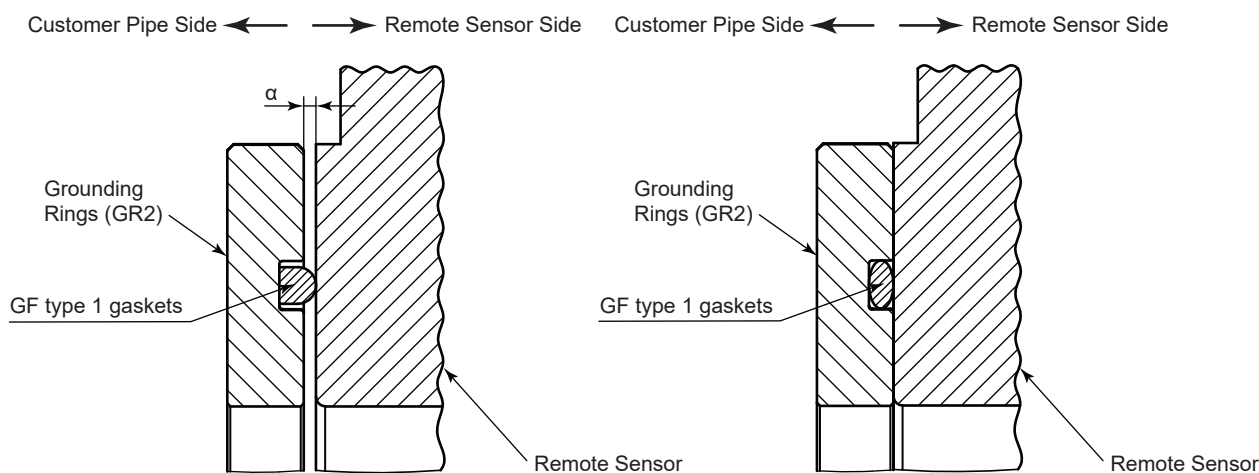

F16.ai

● Grounding Ring (Optional Code GR1) for size 1100 to 1800 mm (44 to 72 in.)

Unit: mm (approx. in.)

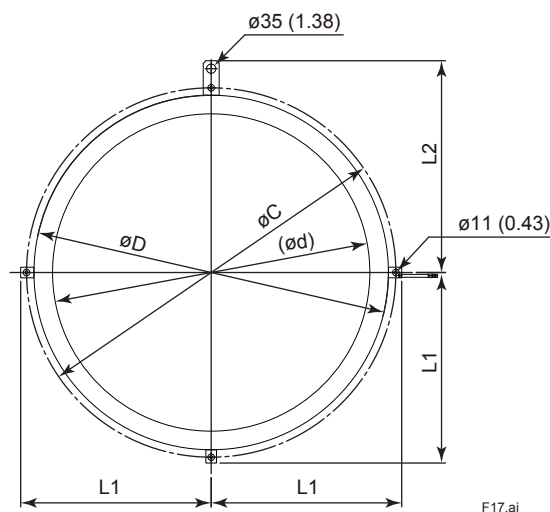

F17.ai

Unit: mm (approx. in.)

Process Connection Code	CB1, CS1, CS2, CT1	CEJ				CEK, CE1			
Flange Type	AWWA C207-D AS2129-D, E AS4087 PN16	EN1092-1 PN6				EN1092-1 PN10			
Size Code	12L	12L	14L	16L	18L	12L	14L	16L	18L
Size	1200 (48)	1200 (48)	1400 (56)	1600 (64)	1800 (72)	1200 (48)	1400 (56)	1600 (64)	1800 (72)
Lining Code	H								
Ring Outer Diameter $\varnothing D$	1370 (53.94)	1300 (51.18)	1516 (59.69)	1716 (67.56)	1925 (75.79)	1335 (52.56)	1540 (60.63)	1766 (69.53)	1966 (77.40)
Ring Inner Diameter $\varnothing d$	1195 (47.05)	1201 (47.28)	1404 (55.28)	1592 (62.68)	1790 (70.47)	1195 (47.05)	1396 (54.96)	1588 (62.52)	1782 (70.16)
Bolt Circle Diameter $\varnothing C$	1426 (56.14)	1356 (53.39)	1572 (61.89)	1772 (69.76)	1981 (77.99)	1391 (54.76)	1596 (62.83)	1822 (71.73)	2022 (79.61)
Length L1	735 (28.94)	700 (27.56)	808 (31.81)	908 (35.75)	1012.5 (39.86)	717.5 (28.25)	820 (32.28)	933 (36.73)	1033 (40.67)
Length L2	815 (32.09)	780 (30.71)	888 (34.96)	988 (38.90)	1092.5 (43.01)	797.5 (31.40)	900 (35.43)	1013 (39.88)	1113 (43.82)
Thickness	5 (0.20)								
Approx. Weight, Unit: kg (lb)	14.6 (32.2)	8.2 (18.1)	10.7 (23.6)	13.3 (29.3)	16.2 (35.7)	11.6 (25.6)	13.7 (30.2)	19.2 (42.3)	22.1 (48.7)

● Grounding Ring (Optional Code GR2) for size 1100 to 1800 mm (44 to 72 in.)

Unit: mm (approx. in.)

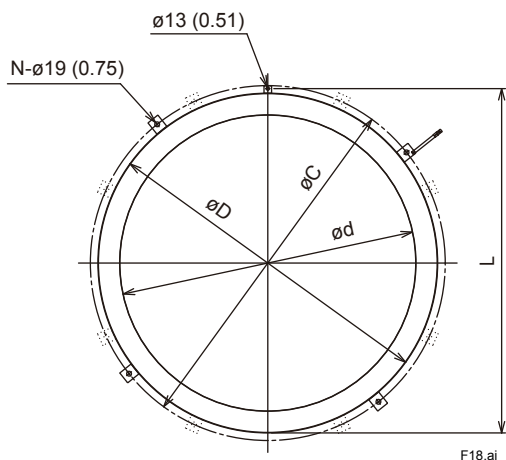

Unit: mm (approx. in.)

Process Connection Code	CG1					
Flange Type	JIS G3443-2 F12					
Size Code	11L	12L	13L	15L	16L	18L
Size	1100 (44)	1200 (48)	1350 (54)	1500 (60)	1600 (64)	1800 (72)
Lining Code	U					
Ring Outer Diameter $\varnothing D$	1242 (48.90)	1346 (52.99)	1502 (59.13)	1658 (65.28)	1764 (69.45)	1972 (77.64)
Ring Inner Diameter $\varnothing d$	1071 (42.17)	1172 (46.14)	1322 (52.05)	1469 (57.83)	1565 (61.61)	1759 (69.25)
Bolt Circle Diameter $\varnothing C$	1302 (51.26)	1406 (55.35)	1562 (61.50)	1718 (67.64)	1824 (71.81)	2032 (80.00)
Length L	1260 (49.61)	1364 (53.70)	1520 (59.84)	1676 (65.98)	1782 (70.16)	1990 (78.35)
Number of Bolt Holes N	4	4	4	4	4	8
Thickness	25 (0.98)					
Approx. Weight, Unit: kg (lb)	59.3 (131)	65.7 (145)	75.8 (167)	88.3 (195)	92.4 (204)	114.2 (252)

*: The grounding rings (optional code GR2) have no protruding brackets. Refer to "CAUTIONS ON SELECTION AND INSTALLATION".

● Limit Deviation

Unless otherwise specified, size limit deviation on the drawings are as shown in the following table.

General limit deviation in the dimensional outline drawing.

Unit: mm (approx. in.)

Category of basic size		Limit deviation	Category of basic size		Limit deviation
Above	Equal or below		Above	Equal or below	
	3 (0.12)	±0.7 (±0.03)	500 (19.69)	630 (24.80)	±5.5 (±0.22)
3 (0.12)	6 (0.24)	±0.9 (±0.04)	630 (24.80)	800 (31.50)	±6.25 (±0.25)
6 (0.24)	10 (0.39)	±1.1 (±0.04)	800 (31.50)	1000 (39.37)	±7.0 (±0.28)
10 (0.39)	18 (0.71)	±1.35 (±0.05)	1000 (39.37)	1250 (49.21)	±8.25 (±0.32)
18 (0.71)	30 (1.18)	±1.65 (±0.06)	1250 (49.21)	1600 (62.99)	±9.75 (±0.38)
30 (1.18)	50 (1.97)	±1.95 (±0.08)	1600 (62.99)	2000 (78.74)	±11.5 (±0.45)
50 (1.97)	80 (3.15)	±2.3 (±0.09)	2000 (78.74)	2500 (98.43)	±14.0 (±0.55)
80 (3.15)	120 (4.72)	±2.7 (±0.11)	2500 (98.43)	3150 (124.02)	±16.5 (±0.65)
120 (4.72)	180 (7.09)	±3.15 (±0.12)			
180 (7.09)	250 (9.84)	±3.6 (±0.14)			
250 (9.84)	315 (12.40)	±4.05 (±0.16)			
315 (12.40)	400 (15.75)	±4.45 (±0.18)			
400 (15.75)	500 (19.69)	±4.85 (±0.19)			

Remarks: The numeric is based on criteria of standard tolerance grade IT18 in JIS B 0401-1.

■ SIZING DATA

* Measurable flow velocity is from 0 m/s.

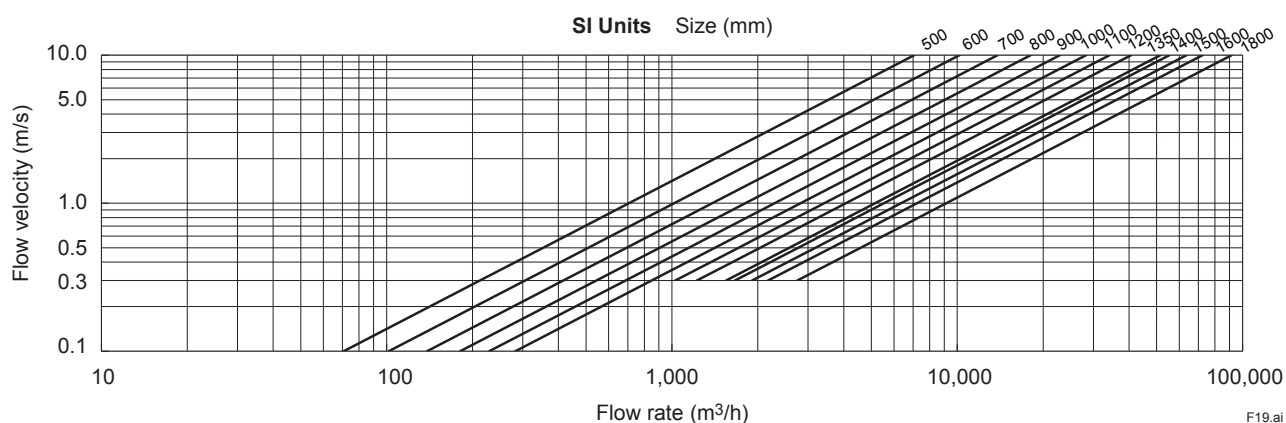

* Measurable flow velocity is from 0 ft/s.

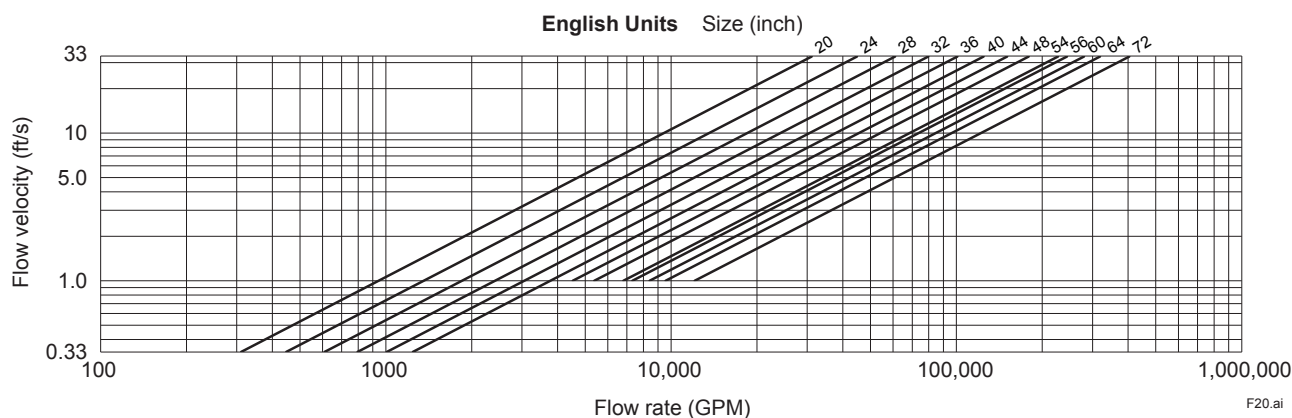

ORDERING INFORMATION

Note 1: When ordering, the span flow rate, unit, output pulse weight, and totalizer display pulse weight can be specified. These parameters will be set before shipment. In the case of remote type, specify combination information of sensor (or flowtube) and transmitter (or converter). These parameters will be set in the combined transmitter. When ordering of a remote sensor alone or a remote transmitter alone, these parameters cannot be specified. Custom configuration request is necessary for setting these parameters out of regular setting range.

Note 2: Some options, if ordered, require the relevant specifications to be input when ordering.

Note 3: For AXW4A FOUNDATION fieldbus type remote transmitter, read general specifications (GS 01E21F02-01EN). For AXW4A PROFIBUS PA type remote transmitter, read general specifications (GS 01E21F02-03EN). For AXG1A remote transmitter, read general specifications (GS 01E22C01-01EN). For AXFA11G remote transmitter, read general specifications (GS 01E20C01-01E). The contents and conditions of ordering informations are different.

1. Model, Suffix Code and Optional Code
2. Combination

This is necessary when ordering combination of remote sensor and transmitter. Specify the combination of a sensor and a transmitter one by one by their model name, specification code, or Tag No. etc. On the nameplate of each sensor and transmitter, the serial number of the specified combination partner is described when shipped.

3. Tag No.

The Tag No. can be specified by a combination of the characters shown in the following table.

Symbol	-	Hyphen-minus	.	Period		Space (*1)
	_	Underscore	=	Equal sign	+	Plus sign
	/	Slash	(Left round bracket)	Right round bracket
	:	Colon	#	Hash mark	!	Exclamation mark
Number	0, 1, 2, 3, 4, 5, 6, 7, 8, 9					
Uppercase letter	A, B, C, D, E, F, G, H, I, J, K, L, M, N, O, P, Q, R, S, T, U, V, W, X, Y, Z					
Lowercase letter (*2)	a, b, c, d, e, f, g, h, i, j, k, l, m, n, o, p, q, r, s, t, u, v, w, x, y, z					

*1: Leading and trailing space characters are deleted and left-justified, then printed on the name plate/ tag plate and written to the amplifier memory.

*2: When Communication and I/O code J# (HART communication) is specified, the lowercase letters are converted to uppercase and written to the parameter "Tag". For parameter "Long Tag", they are written in lowercase as is.

Tag No. can be "described on the nameplate and stainless steel tag plate (optional code SCT)" and "set to the amplifier memory in the transmitter". Refer to the following table for the item to be specified.

Described/setting destination	Items to be specified	Maximum number of characters
• Name plate • Stainless steel tag plate (Optional code SCT)	TAG NO	16
• Amplifier memory (Integral flowmeter)		16 There are restrictions on the write destination parameters. Read the next table.
	SOFTWARE TAG (Overrides TAG NO designation)	Read the next table

The characters specified by "TAG NO" are also written to the amplifier memory (parameter). If it is necessary to specify a different tag number only for the amplifier memory, specify "SOFTWARE TAG". It is also possible to specify only SOFTWARE TAG. Names of the parameter to be written and the maximum number of characters are as shown in the following table. If the number of specified characters exceed the maximum number, the characters from the beginning up to the maximum number is written.

Tag No. in amplifier memory (Integral flowmeter)			
Items to be Specified	Communication	Parameter Name	Maximum Number of Characters
TAG NO or SOFTWARE TAG	BRAIN	TAG NO	16
	HART	Long Tag	32
		Tag	8
	Modbus	Long Tag	32
		Tag	16
	FOUNDATION fieldbus	PDTAG	32
PROFIBUS PA	PB.TAG_DESC	32	

4. Range and Unit of Flowrate Span

Specify the range of 0.0001 to 32000, it is up to four digits below the decimal point when it is included, and the numerical value excluding the decimal point is within 32000.

Specify units in the unit described in "Flow Calculation Function". This span flow rate is set to the positive first range. Be sure to specify the range and unit of flowrate span when selecting the Mass Unit Setting (optional code MU), or Specified Span Five-point Calibration (optional code SC).

Unless specified, it is set as the following when shipped.

- Integral Flowmeter, or combined with AXW4A or AXG1A Remote Transmitter span flow rate (unit m^3/h) equivalent to flow velocity 1 m/s
- Combined with AXFA11 Remote Transmitter flow velocity 1 m/s

The measurement flow range (minimum and maximum of span flow rate) is shown below (in the case of flow rate unit m^3/h and GPM). Specify the span flow within this range. The range specifying different unit must also fall into the same flow rate (flow velocity) range after conversion.

Measurable Flow Rate Range**(1) Integral Flowmeter, or combined with AXW4A Remote Transmitter**SI Units (Size: mm, Flow rate: m³/h)

Size (mm)	0 to Min. Span Flow Rate m ³ /h (0.1 m/s)	0 to Max. Span Flow Rate m ³ /h (10 m/s)
500	0 to 70.6859	0 to 7068.58
600	0 to 101.788	0 to 10178.7
700	0 to 138.545	0 to 13854.4
800	0 to 180.956	0 to 18095.5
900	0 to 229.023	0 to 22902.2
1000	0 to 282.744	0 to 28274.3

English Units (Size: in., Flow rate: GPM)

Size (in.)	0 to Min. Span Flow Rate GPM (0.33 ft/s)	0 to Max. Span Flow Rate GPM (33 ft/s)
20	0 to 311.221	0 to 31122.0
24	0 to 448.158	0 to 44815.7
28	0 to 609.992	0 to 60999.1
32	0 to 796.725	0 to 79672.4
36	0 to 1008.36	0 to 100835
40	0 to 1244.89	0 to 124488

(2) Combined with AXG1A Remote TransmitterSI Units (Size: mm, Flow rate: m³/h)

Size (mm)	0 to Min. Span Flow Rate m ³ /h (0.1 m/s)	0 to Max. Span Flow Rate m ³ /h (10 m/s)
500	0 to 70.6859	0 to 7068.58
600	0 to 101.788	0 to 10178.7
700	0 to 138.545	0 to 13854.4
800	0 to 180.956	0 to 18095.5
900	0 to 229.023	0 to 22902.2
1000	0 to 282.744	0 to 28274.3

English Units (Size: in., Flow rate: GPM)

Size (in.)	0 to Min. Span Flow Rate GPM (0.33 ft/s)	0 to Max. Span Flow Rate GPM (33 ft/s)
20	0 to 311.221	0 to 31122.0
24	0 to 448.158	0 to 44815.7
28	0 to 609.992	0 to 60999.1
32	0 to 796.725	0 to 79672.4
36	0 to 1008.36	0 to 100835
40	0 to 1244.89	0 to 124488

Size: mm (in.), Flow rate: m³/h (GPM)

Size mm (in.)	0 to Min. Span Flow Rate 0.3 m/s (1 ft/s)	0 to Max. Span Flow Rate 10 m/s (33 ft/s)
1100 (44)	0 to 1,026.4 (0 to 4,519 GPM)	0 to 34,211 (0 to 150,630 GPM)
1200 (48)	0 to 1,221.5 (0 to 5,378)	0 to 40,715 (0 to 179,262)
1350 (54)	0 to 1,545.9 (0 to 6,807)	0 to 51,529 (0 to 226,879)
1400 (56)	0 to 1,662.5 (0 to 7,320)	0 to 55,418 (0 to 243,997)
1500 (60)	0 to 1,908.6 (0 to 8,403)	0 to 63,617 (0 to 280,098)
1600 (64)	0 to 2,171.5 (0 to 9,561)	0 to 72,382 (0 to 318,689)
1800 (72)	0 to 2,748.3 (0 to 12,101)	0 to 91,608 (0 to 403,341)

(3) Combined with AXFA11 Remote TransmitterSize: mm (in.), Flow rate: m³/h (GPM)

Size mm (in.)	0 to Min. Span Flow Rate 0.1 m/s (0.33 ft/s)	0 to Max. Span Flow Rate 10 m/s (33 ft/s)
500 (20)	0 to 70.69 (0 to 311.3)	0 to 7,068 (0 to 31,122)
600 (24)	0 to 101.79 (0 to 448.2)	0 to 10,178 (0 to 44,815)
700 (28)	0 to 138.55 (0 to 610.0)	0 to 13,854 (0 to 60,999)
800 (32)	0 to 180.96 (0 to 796.8)	0 to 18,095 (0 to 79,672)
900 (36)	0 to 229.03 (0 to 1,009)	0 to 22,902 (0 to 100,835)
1000 (40)	0 to 282.75 (0 to 1,245)	0 to 28,274 (0 to 124,488)

Size: mm (in.), Flow rate: m³/h (GPM)

Size mm (in.)	0 to Min. Span Flow Rate 0.3 m/s (1 ft/s)	0 to Max. Span Flow Rate 10 m/s (33 ft/s)
1100 (44)	0 to 1,026.4 (0 to 4,519 GPM)	0 to 34,211 (0 to 150,630 GPM)
1200 (48)	0 to 1,221.5 (0 to 5,378)	0 to 40,715 (0 to 179,262)
1350 (54)	0 to 1,545.9 (0 to 6,807)	0 to 51,529 (0 to 226,879)
1400 (56)	0 to 1,662.5 (0 to 7,320)	0 to 55,418 (0 to 243,997)
1500 (60)	0 to 1,908.6 (0 to 8,403)	0 to 63,617 (0 to 280,098)
1600 (64)	0 to 2,171.5 (0 to 9,561)	0 to 72,382 (0 to 318,689)
1800 (72)	0 to 2,748.3 (0 to 12,101)	0 to 91,608 (0 to 403,341)

5. Output Pulse Weight (Pulse Status Output 1)

Specify the volume flow per pulse, after specifying the span flow rate. This output pulse weight is set to the Pulse Status Output 1. Specify it in the same unit as the span flow rate.

(Example: When "m³" is selected as "Span Flow Rate", specify "10 m³/p" as pulse weight unit.)

The specifiable numerical digit and range is the same as that for "4. Range and Unit of Flowrate Span.

Unless specified, it is set as the following when shipped.

- Integral Flowmeter, or combined with AXW4A or AXG1A Remote Transmitter 0 [span unit/p]
- Combined with AXFA11 Remote Transmitter 0 pulse/s

6. Totalizer Display Pulse Weight (Totalizer 1)

Specify the volume flow per pulse, after specifying the span flow rate. This totalizer display pulse weight is set to the Totalizer 1. Specify it in the same unit as the span flow rate.

(Example: When "m³" is selected as "Span Flow Rate", specify "10 m³/p" as totalizer display pulse weight unit.)

The specifiable numerical digit and range is the same as that for "4. Range and Unit of Flowrate Span.

Unless specified, it is set as the following when shipped.

- Integral Flowmeter, or combined with AXW4A Remote Transmitter 1 [span unit/p]
- Combined with AXFA11 Remote Transmitter 0 pulse/s

7. Mass Unit (optional code MU)

The flow rate calculation is performed in mass unit. In addition to fluid density, specify span flow rate, output pulse weight, and totalizer display pulse weight in mass unit.

The specifiable numerical digit and range is the same as that for “4. Range and Unit of Flowrate Span.

(1) Density

Numerical Value:

Specify within six digits (up to three digits below the decimal point) in the range of 500 to 2000 kg/m³ (4.2 to 16.7 lb/gal, 31.2 to 124.8 lb/cf). If BRAIN communication type is selected, specify so that the numerical value excluding the decimal point is within 32000.

Unit:

kg/m³, lb/gal, lb/cf

The density of water is about 1000 kg/m³. Then specify “1000 kg/m³” in this case. However, as the density varies with temperature, specify the density at the time of flow measurement.

(2) Span Flow Rate

Numerical Value:

When setting the mass span flow rate, calculate the volume span flow rate from the “density” and it must be within the measurable flow rate range. The settable numerical range for the mass span flow rate is the same as that for the volume span flow rate.

Unit:

Mass Unit: t, kg, g, klb, lb

Time Unit: /d, /h, /min, /s

(3) Output Pulse Weight, Totalizer Display Pulse Weight

Set the value with the same unit as that for the mass span flow rate.

8. Specified Span Five-point Calibration (optional code SC)

A flow test at the five points around 0, 25, 50, 75, 100% of the customer specified span is performed. In the test certificate (QIC), the result for the customer specified span is recorded instead of that for the standard flow rate of 2 m/s (6.56 ft/s). Corresponding flow velocity of the selectable span lies between 0.5 to 10 m/s (1.64 to 33 ft/s) or 0.8 to 10 m/s (2.62 to 33 ft/s). The latter is applied when the size is 32, 65, or 125 mm (1.25, 2.5, or 5 in.). It is also limited by the capacity of our flow test facility. Specify it within the following range. The specifiable numerical digit and range is the same as that for “4. Span Flow Rate and Unit”.

Selectable Range of Span Flow Rate

SI Units (Size: mm, Flow rate: m³/h)



Size mm	Min. Span Flow Rate	Max. Span Flow Rate
	m ³ /h (m/s)	m ³ /h (m/s)
500	354 (0.5)	7068 (10.00)
600	509 (0.5)	8200 (8.06)
700	693 (0.5)	8200 (5.92)
800	905 (0.5)	8200 (4.53)
900	1146 (0.5)	8200 (3.58)
1000	1414 (0.5)	8200 (2.90)
1100	1711 (0.5)	8200 (2.40)
1200	2036 (0.5)	8200 (2.01)
1350	2577 (0.5)	30000 (5.82)
1400	2771 (0.5)	30000 (5.41)
1500	3181 (0.5)	30000 (4.71)
1600	3620 (0.5)	30000 (4.14)
1800	4581 (0.5)	30000 (3.27)

English Units (Size: in., Flow rate: GPM)

Size in.	Min. Span Flow Rate	Max. Span Flow Rate
	GPM (ft/s)	GPM (ft/s)
20	1556.11 (1.64)	31119.4 (32.81)
24	2240.79 (1.64)	36103.5 (26.44)
28	3049.96 (1.64)	36103.5 (19.42)
32	3983.63 (1.64)	36103.5 (14.86)
36	5041.77 (1.64)	36103.5 (11.75)
40	6224.41 (1.64)	36103.5 (9.51)
44	7531.54 (1.64)	36103.5 (7.87)
48	8963.15 (1.64)	36103.5 (6.59)
54	11344.0 (1.64)	132086 (19.09)
56	12199.9 (1.64)	132086 (17.75)
60	14005.0 (1.64)	132086 (15.45)
64	15934.5 (1.64)	132086 (13.58)
72	20167.1 (1.64)	132086 (10.73)

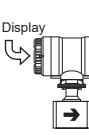
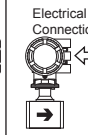
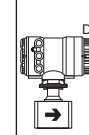
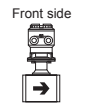

9. Direction of Electrical Connection (Cable Entry) (optional code RA, RB, RC)

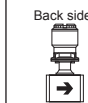
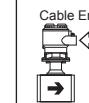
Rotate the transmitter of integral flowmeter or the terminal box of remote sensor and change the direction of the electrical connection. See the table below and select an optional code for +90, +180, or -90 degree. When the direction of electrical connection is not changed, optional codes are not necessary.

	Direction of Electrical Connection (Cable Entry)			
	Standard (0 degree)	+90 degree rotation Optional Code RA	+180 degree rotation Optional Code RB	-90 degree rotation Optional Code RC
Integral Flowmeter				
Remote Sensor				

10. Direction of Indicator (Display)

When the specification "With Indicator" is selected for the integral flowmeter, specify direction of the indicator according to the horizontal or vertical direction of the installation piping.

	Direction of Indicator		Without Indicator
	Horizontal	Vertical	
Integral Flowmeter			

11. Fluid Name

12. Modbus protocol parameters

Specify the following parameters for Modbus communication.

Parameter to be specified	Selectable value
Baud rate [bps]	1200, 2400, 4800, 9600, 19200*, 38400, 57600, 115200
Stop bit	1 bit*, 2 bits
Parity bit	Odd, Even*, None
Slave address	1* to 247 (decimal value.)

*: Factory default setting. If the parameter is not specified at ordering, these settings are applied to the parameter for Modbus communication.

■ RELATED INSTRUMENTS

Product	Document Number
AM012 Calibrator for Magnetic Flowmeter	GS 1E6K2-E
BT200 BRAIN TERMINAL	GS 01C00A11-00EN
AXFA11G Magnetic Flowmeter Remote Converter	GS 01E20C01-01E
AXG1A Magnetic Flowmeter Remote Transmitter	GS 01E22C01-01EN
ADMAG CA Capacitance Magnetic Flowmeter	GS 01E08B01-00E
FieldMate Versatile Device Management Wizard	GS 01R01A01-01E
ADMAG TI Series AXG Magnetic Flowmeter	GS 01E22A01-01EN
ADMAG TI Series AXW Magnetic Flowmeter [Size: 25 to 400 mm (1 to 16 in.)]	GS 01E24A01-01EN
ADMAG TI Series FOUNDATION fieldbus	GS 01E21F02-01EN
ADMAG TI Series PROFIBUS PA	GS 01E21F02-03EN
FSA130 ADMAG TI Verification Tool	GS 01E21A04-01EN

■ REFERENCE STANDARD

Design and Test on Magnetic Flowmeters:
JIS B 7554(1997), ISO 20456(2017),
NAMUR NE70(2006), ASME MFC-16-2014

■ TRADEMARKS

HART is a registered trademark of FieldComm Group.

HASTELLOY is a registered trademark of Haynes International, Inc.

Modbus is a registered trademark of AEG Schneider.

"FOUNDATION" in "FOUNDATION fieldbus" is a registered trademark of FieldComm Group.

PROFIBUS is a registered trademark of Profibus Nutzerorganisation e.v., Karlsruhe, Germany.

ADMAG, AXG, AXW, BRAIN TERMINAL, and FieldMate are registered trademarks of Yokogawa Electric Corporation.

Company names and product names used in this material are registered trademarks or trademarks of their respective owners.

All other company and product names mentioned in this document are trade names, trademarks or registered trademarks of their respective companies.

In this document, trademarks or registered trademarks are not marked with TM or [®].

Note: The terms "transmitter" and "sensor" in this document are used in the same manner as "converter" and "flowtube" respectively which have been used for our magnetic flowmeter models.

<Information on EU WEEE Directive>

EU WEEE (Waste Electrical and Electronic Equipment) Directive is only valid in the EU.

This instrument is intended to be sold and used only as a part of equipment which is excluded from WEEE Directive, such as large-scale stationary industrial tools, a large-scale fixed installation and so on, and, therefore, subjected to the exclusion from the scope of the WEEE Directive. The instrument should be disposed of in accordance with local and national legislation/regulations.