

**ADMAG TI Series  
AXG, AXW  
Magnetic Flowmeter  
HART Communication Type**



IM 01E21A02-02EN

---

# ADMAG TI Series

## AXG, AXW Magnetic Flowmeter

### HART Communication Type

IM 01E21A02-02EN 5th Edition

## Contents

<b>1.</b>	<b>Introduction.....</b>	<b>6</b>
1.1	For Safe Use of Product.....	9
1.2	Warranty.....	11
<b>2.</b>	<b>Operation by Display unit.....</b>	<b>12</b>
2.1	Basic Operating Procedures.....	12
2.2	Display and Basic Configuration.....	13
2.2.1	Display Configuration.....	13
2.2.2	Operation Level.....	16
2.3	Display Mode and Setting Mode.....	16
2.4	Parameter Setting from Display Panel.....	20
2.4.1	Setting Example of Select Type Parameter (Flow rate unit).....	20
2.4.2	Setting Example of Numeric Type Parameter (Flow rate span).....	21
2.4.3	Setting Example of Alphanumeric Type Parameter (Tag No.).....	22
2.5	microSD Card Insertion/Removal.....	23
<b>3.</b>	<b>Operation with HART Configuration Tool.....</b>	<b>24</b>
3.1	Connecting HART Configuration Tool.....	24
3.2	HART Configuration Tool and Device Revision.....	25
3.2.1	Device Description (DD) and Device Revision.....	25
3.2.2	Device Type Manager (DTM) and Device Revision.....	26
3.3	Basic Setup.....	27
3.4	Parameter Configuration.....	28
3.5	Data Renewing and Upload/Download Function.....	28
3.6	Specific Functions of HART Configuration Tool.....	31
3.6.1	Process Variable Setting (Dynamic Variables).....	31
3.6.2	Burst Mode.....	32
3.6.3	Event Notification.....	35
3.6.4	Multidrop Mode.....	36
<b>4.</b>	<b>Functions.....</b>	<b>38</b>
4.1	Basic Settings.....	40
4.1.1	Overview.....	40
4.1.2	PV Mapping of Process Value.....	41
4.1.3	Display of the Process Value.....	41
4.1.4	Unit Setting.....	43

4.1.5	Span Setting.....	44
4.1.6	Damping Time Constant Setting.....	45
4.1.7	Low-cut Function Setting .....	46
4.1.8	Meter Factor Setting .....	49
4.1.9	Sensor Type Setting.....	50
4.1.10	Sensor's Nominal Size Setting .....	51
4.1.11	Density Setting.....	51
4.1.12	Temperature Setting .....	52
4.1.13	Span Flow Velocity Display.....	52
4.1.14	User Span Function .....	53
4.1.15	Zero Adjustment.....	55
<b>4.2</b>	<b>Totalization Function .....</b>	<b>57</b>
4.2.1	Totalized Value and Unit Setting .....	57
4.2.2	Totalized Value Display and Totalization Function.....	57
4.2.3	Totalization Switch Function .....	59
4.2.4	Totalizer Operation at Alarm Occurrence.....	60
4.2.5	Start/Stop Setting for Totalization Function.....	61
4.2.6	Totalization Direction Setting .....	61
4.2.7	Totalized Value Reset/Preset Function.....	62
<b>4.3</b>	<b>Pulse Output, Frequency Output, and Status Output.....</b>	<b>63</b>
4.3.1	Pulse/Status Output Mode Setting .....	63
4.3.2	Pulse Output/Frequency Output Mapping.....	64
4.3.3	Alarm Output Function.....	64
4.3.4	Pulse Width Setting.....	65
4.3.5	Active Direction Setting.....	66
4.3.6	Active Pulse Setting .....	67
4.3.7	Pulse Rate Setting .....	67
4.3.8	Frequency Output Range Setting .....	69
4.3.9	Status Output Function Setting.....	70
4.3.10	Pulse Option Setting .....	73
<b>4.4</b>	<b>Status Input.....</b>	<b>74</b>
4.4.1	Active Direction Setting for Status Input .....	74
4.4.2	Status Input Function Setting.....	75
<b>4.5</b>	<b>Analog Input and Analog Output .....</b>	<b>76</b>
4.5.1	Analog Output Select.....	76
4.5.2	Display Analog Output .....	76
4.5.3	Analog Output High/Low Limit Function .....	77
4.5.4	Absolute Range Function .....	78
4.5.5	Alarm Output Function.....	79
4.5.6	Analog Output Priority.....	79
4.5.7	Current Value Adjustment .....	80
4.5.8	Analog Input Function Setting.....	81

4.5.9	Display Analog Input .....	81
4.5.10	Analog Input Unit Setting .....	81
4.5.11	Analog Input Range Setting .....	82
4.5.12	Analog Input High/Low Limit Function .....	82
<b>4.6</b>	<b>Multi Range Function .....</b>	<b>83</b>
4.6.1	Multi Range type .....	83
4.6.2	Multi Range Setting .....	83
4.6.3	Multi Range Operation .....	84
4.6.4	Forward/Reverse Range .....	86
4.6.5	Combination of Multi Range and Forward/Reverse Range .....	88
4.6.6	External Contact Range .....	89
4.6.7	External Contact Range (with Answer) .....	90
4.6.8	Combination of External Contact Range and Forward/Reverse Range .....	91
<b>4.7</b>	<b>Auxiliary Calculation Function .....</b>	<b>92</b>
4.7.1	Fluid Flow Direction Setting .....	92
4.7.2	Rate Limit Function Setting .....	92
4.7.3	Pulsing Flow Support Function Setting .....	95
4.7.4	Power Frequency Synchronization Setting .....	95
4.7.5	Density Correction Calculation .....	96
4.7.6	Calorie Calculation .....	98
4.7.7	Limit of Alarm Output Function .....	99
<b>4.8</b>	<b>Alarm .....</b>	<b>100</b>
4.8.1	Errors and Countermeasures .....	100
4.8.2	Operation at the Time of Error .....	106
4.8.3	Alarm Display Setting .....	110
4.8.4	Alarm History Function .....	111
4.8.5	Alarm Mask Function .....	112
4.8.6	Burnout Direction Display .....	119
<b>4.9</b>	<b>Display .....</b>	<b>120</b>
4.9.1	Language Setting .....	120
4.9.2	Display Item Setting .....	121
4.9.3	Decimal-point Position Setting .....	122
4.9.4	Display Line Count and Scroll Settings .....	124
4.9.5	Trend Graph Setting .....	125
4.9.6	Update Period Setting .....	127
4.9.7	Other Settings .....	128
4.9.8	microSD Card Setting .....	131
<b>4.10</b>	<b>Device Information .....</b>	<b>133</b>
4.10.1	Order Information .....	133
4.10.2	Device Revision .....	134
4.10.3	Memo Function .....	135

4.10.4	Date and Time Information .....	135
4.10.5	Display Operation Time .....	136
4.10.6	Explosion Protection Setting .....	136
<b>4.11</b>	<b>Self-diagnostic Function .....</b>	<b>137</b>
4.11.1	Types of Diagnosis Functions .....	137
4.11.2	Alarm High/Low Limit Function .....	137
4.11.3	Electrode Adhesion Detection .....	139
4.11.4	Sensor Empty Check .....	140
4.11.5	Wiring Connection Diagnosis .....	141
4.11.6	Verification (Device Health Diagnosis) Function .....	142
4.11.7	Electrode Insulation Deterioration Diagnosis .....	146
4.11.8	Flow Noise Diagnosis .....	147
4.11.9	Low Conductivity Diagnosis .....	148
4.11.10	Coil Insulation Diagnosis .....	149
4.11.11	Other Setting .....	149
<b>4.12</b>	<b>Test Mode .....</b>	<b>150</b>
4.12.1	Test Mode Setting .....	150
4.12.2	Test Value Setting .....	151
4.12.3	Test 2 Mode .....	152
4.12.4	Test Mode Auto Reset .....	152
<b>4.13</b>	<b>Event Management Function .....</b>	<b>153</b>
4.13.1	Backup Function .....	153
4.13.2	Restore/Duplicate Parameter .....	156
4.13.3	Backup and Restore Parameters .....	160
4.13.4	Data Logging Function .....	164
<b>4.14</b>	<b>Parameter Protection .....</b>	<b>167</b>
4.14.1	Software Write Protection Function .....	167
4.14.2	Display Restriction Function .....	168
<b>5.</b>	<b>Parameter Lists .....</b>	<b>169</b>
5.1	Display Parameters .....	171
5.2	Easy Configuration Parameters .....	172
5.3	Basic Configuration Parameters .....	174
5.4	Totalization Configuration Parameters .....	177
5.5	Pulse Output Configuration Parameters .....	181
5.6	Status Input and Output Configuration Parameters .....	184
5.7	Analog Output/Input Configuration Parameters .....	186
5.8	Auxiliary Function Configuration Parameters .....	188
5.9	Alarm Configuration Parameters .....	190
5.10	Display Configuration Parameters .....	195
5.11	Device Information Configuration Parameters .....	198
5.12	Diagnosis Function Configuration Parameters .....	201
5.13	Test Mode Configuration Parameters .....	204

---

5.14	Backup/Restore/Data Logging Configuration Parameters .....	206
5.15	Parameter Protection Parameters .....	208
<b>6.</b>	<b>Parameter Menu Tree .....</b>	<b>209</b>
6.1	Display Menu Tree .....	209
6.2	HART Communication Menu Tree .....	226
	<b>Revision Information .....</b>	<b>242</b>

# 1. Introduction

This manual explains basic operations of ADMAG TI Series AXG, AXW Magnetic Flowmeter with HART Communication Protocol.

For items which are not covered in this manual, read the applicable user's manuals listed in "Table 1.1 Manual and General Specifications List" in the ADMAG TI Series Installation Manual. These documents can be downloaded from the YOKOGAWA website. To ensure the correct use of the product, read these manuals thoroughly and fully understand how to operate the product before operating it. To confirm the model name and specifications of the product, refer to the general specifications.

Website address: <https://www.yokogawa.com/library/>

## ■ Precautions Related to the Protection, Safety, and Alteration of the Product

The following safety symbol marks are used in this manual and the product.



### **WARNING**

A WARNING sign denotes a hazard. It calls attention to a procedure, practice, condition, or the like, which, if not correctly performed or adhered to, could result in injury or death of personnel.



### **CAUTION**

A CAUTION sign denotes a hazard. It calls attention to a procedure, practice, condition, or the like, which, if not correctly performed or adhered to, could result in damage to or destruction of part or all of the product.

### **IMPORTANT**

An IMPORTANT sign denotes that attention is required to avoid damage to the product or system failure.

### **NOTE**

A NOTE sign denotes information necessary for an essential understanding of operation and features.

The following symbols are used in the product and the manual to indicate the accompanying safety precautions:

 Protective grounding terminal

 Functional grounding terminal  
(This terminal should not be used as a protective grounding terminal.)

 Alternating current

 Direct current

 Caution

This symbol indicates that the operator must refer to an explanation in the user's manual in order to avoid the risk of injury or death of personnel or damage to the product.

For the protection and safe use of the product and the system in which this product is incorporated, be sure to follow the instructions and precautions on safety that are stated in user's manual whenever you handle the product. Take special note that if you handle the product in a manner that violates these instructions, the protection function of the product may be damaged or impaired. In such a case, YOKOGAWA does not guarantee the quality, performance, function, or safety of the product.

## ■ Regarding This User's Manual

- This manual should be provided to the end user.
- The contents of this manual are subject to change without prior notice.
- No part of this manual may be reproduced in any form without YOKOGAWA's written permission.
- YOKOGAWA makes no warranty of any kind with regard to this manual, including, but not limited to, implied warranty of merchantability and fitness for a particular purpose.
- If any questions arise or errors are found, or if any information is missing from this manual, inform the nearest YOKOGAWA sales office.
- The specifications covered by this manual are limited to those for the standard type under the specified model number break-down and do not cover custom-made products.
- Note that changes in the specifications, construction, or component parts of the product may not immediately be reflected in this manual at the time of change, provided that postponement of revisions will not cause difficulty to the user from a functional or performance standpoint.
- This manual is intended for the following personnel:
  - Engineers responsible for the installation and wiring of the product.
  - Personnel responsible for the normal daily operation of the product (operator).
- To ensure correct use, read this manual and the applicable manuals thoroughly before starting operation. Read the general specifications for specifications of the product.



---

## ■ Trademarks

- All the brands or names of Yokogawa Electric's products used in this manual are either trademarks or registered trademarks of Yokogawa Electric Corporation.
- All other company and product names mentioned in this manual are trade names, trademarks or registered trademarks of their respective companies.
- In this manual, trademarks and registered trademarks are not marked with "™" or "®".
- HART is a registered trademark of FieldComm Group.

## 1.1 For Safe Use of Product

For the protection and safe use of the product and the system in which this product is incorporated, be sure to follow the instructions and precautions on safety that are stated in user's manual whenever you handle the product. Take special note that if you handle the product in a manner that violates these instructions, the protection function of the product may be damaged or impaired. In such a case, YOKOGAWA shall not be liable for any indirect or consequential loss incurred by either using or not being able to use the product.

### ■ General



#### **WARNING**

- Do not open the cover in wet weather or humid environments. When the cover is open, the stated enclosure protection is not applicable.
- When opening the cover, wait for more than 20 minutes after turning off the power. Only an expert engineer or skilled personnel is permitted to open the cover.

### ■ Operation



#### **WARNING**

Be sure to enable the write protect function to prevent parameters from being overwritten after finishing parameter setting.

In rare cases, the IR switches may respond unexpectedly to water drops or extraneous substances sticking on the surface of the display panel due to characteristics of the operating principles. The possibility of malfunction arises after rain or cleaning near the place where the flowmeter is installed. Repeatedly turning a flashlight, etc. on and off in the direction of the IR switch may also be the cause of malfunction.

Refer to the installation manual for the hardware write protect function, and Section 4.14 for the software write protect function.

### ■ Maintenance



#### **WARNING**

- If dirt, dust, or other substances adheres to the glass of the display, wipe them clean with a soft dry cloth.
- Maintenance of this product should be implemented in a maintenance service shop where necessary tools and environment condition are provided. The required environmental condition is that the ambient temperature should be 5 to 40°C (the maximum relative humidity is 80 % for temperature 5 to 31°C, and decreasing linearly to 50 % relative humidity at 40°C).

## ■ microSD card

### IMPORTANT

---

- Do not store or use the microSD card in places with static electricity, near electrically charged objects, or where electrical noise is present. Doing so can result in shock or damage to the microSD card.
  - Do not disassemble or modify the microSD card.
  - Do not physically shock, bend, or pinch the microSD card.
  - During reading/writing of data, do not turn off the power, apply vibration or shock, or pull out the card. Data can be corrupted or permanently lost.
  - Use only the microSD cards designated by YOKOGAWA. The operation of the device cannot be guaranteed when other cards are used.
  - When inserting the microSD card into the product, make sure to orient the microSD card correctly (face up or down) and insert it securely. If not inserted correctly, the microSD card will not be recognized by the product.
  - Do not touch the microSD card with wet hands.
  - Do not use the microSD card if it is dusty or dirty.
  - The microSD card comes formatted. If you would like to format the microSD card, use the product's Format function.
  - YOKOGAWA provides no warranty for damage to, or loss of data recorded on the microSD card, regardless of the cause of such damage or loss. We recommend regularly making backup copies of your data.
-

---

## 1.2 Warranty

- The warranty shall cover the period described in the quotation presented to the purchaser at the time of purchase. Problems that may occur during the warranty period shall be repaired free of charge.
- In case of problems, the customer should contact the YOKOGAWA representative from which the product was purchased or the nearest YOKOGAWA office.
- If a problem arises with this product, please inform YOKOGAWA of the nature of the problem and the circumstances under which the problem developed, including the model specification and serial number. Any diagrams, data and other information you can include in your communication will also be helpful.
- Responsible part for repair costs of the problems shall be determined by YOKOGAWA based on our investigation.
- The purchaser shall bear the responsibility for repair costs, even during the warranty period, if the malfunction is due to:
  - Improper and/or inadequate maintenance by the purchaser.
  - Failure or damage due to improper handling, use, or storage which does not conform to design conditions.
  - Use of the product in question in a location not conforming to the standards specified by YOKOGAWA, or problems due to improper maintenance of the installation location.
  - Failure or damage due to modification or repair by any party except YOKOGAWA or an approved representative of YOKOGAWA.
  - Malfunction or damage from improper relocation of the product in question after delivery.
  - Reason of force majeure such as fires, earthquakes, storms/floods, thunder/lightning, or other natural disasters, as well as disturbances, riots, warfare, or radioactive contamination.

---

## 2. Operation by Display unit

### 2.1 Basic Operating Procedures

The parameter settings can be changed by using three IR (infra-red) switches; [SET], [SHIFT] and [▼] switches on the display. The three IR switches enable the user to set parameters from the outside of the glass of the display cover.

This section provides descriptions of basic parameter configuration on the display and operation procedures of the IR switches. This product can be also operated by using the dedicated handheld terminal or the FieldMate (Versatile Device Management Wizard). For details about the setting procedure, refer to Chapter 4.



---

#### WARNING

Be sure to enable the write protect function to prevent parameters from being overwritten after finishing parameter setting.

In rare cases, the IR switches may respond unexpectedly to water drops or extraneous substances sticking on the surface of the display panel due to characteristics of the operating principles. The possibility of malfunction arises after rain or cleaning near the place where the flowmeter is installed. Turning on and off the flashlight, etc. towards the IR switch may also be the cause of the malfunction.

Refer to the Installation Manual for the hardware write protect function, and Section 4.14 for the software write protect function.

---

---

#### IMPORTANT

Operate the display under conditions where direct sunlight, etc. do not shine to the IR switches directly when the parameter setting operation is carried out.

---

---

#### NOTE

- Always keep the display cover closed and operate the setting switches from the outside of the glass window.
  - If dirt, dust, or other substances adheres to the glass of the display, wipe them clean with a soft dry cloth.
  - Operation with dirty gloves may cause a switch response error.
- 

---

#### NOTE

The language on the display is set to “English” as default at factory shipment. Select the adequate language referring to Subsection 4.9.1.

The menu pass of the display on this manual is set to “English”.

---

## 2.2 Display and Basic Configuration

The display of the integral flowmeter and remote transmitter has the various functions below.

### 2.2.1 Display Configuration

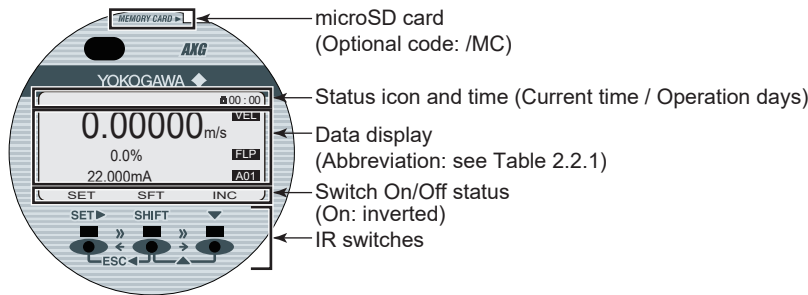

F0201.ai

#### (1) Basic operation of IR switches

The basic operations of the display panel are done by the three IR switches; [SET], [SHIFT], and [▼]. Combining two IR switches provides a different function, and the function of the switch is displayed on the display.





















IR switch (Note 1)	Function of switch (Note 2)	Function
[SET ▶ ]	SET	<ul style="list-style-type: none"> <li>Apply parameter and data (Note 3)</li> <li>Move to next menu</li> </ul>
[SHIFT]	SFT	<ul style="list-style-type: none"> <li>Set/reset Multiple selectable options (Select type parameter)</li> <li>Move cursor right (Numeric type parameter)</li> </ul>
[ ▼ ]	INC	<ul style="list-style-type: none"> <li>Move cursor down (Select type parameter)</li> <li>Increment value (Numeric type parameter)</li> <li>Change position of decimal point (Numeric type parameter)</li> </ul>
[SHIFT] + [ ▼ ] (= [ ▲ ])	DEC	<ul style="list-style-type: none"> <li>Move cursor up (Select type parameter)</li> <li>Decrement value (Numeric type parameter)</li> </ul>
[SHIFT] + [SET ▶ ] (= [ESC ◀ ])	ESC	<ul style="list-style-type: none"> <li>Cancel</li> <li>Back to previous menu</li> </ul>

Note 1: [A] + [B] (= [C]): The function is changed to switch [C] when switch [B] is pressed while pressing switch [A].

Note 2: [SET], [SFT], [INC], [DEC] and [ESC] indicate the assigned function in accordance with display mode at that time. All functions cannot be used simultaneously.

Note 3: "Apply" and "Enter" are executed by pressing [SET] twice. If the execution does not work properly, release your finger from the display glass completely after initially pressing [SET], and then, press that key again.

**(2) Status icons**

Icon	Description	Icon	Description
	Write protection function Disable		Write protection function Enable
	Device Busy		Device Fault
	microSD card Ready		microSD card Accessing
	microSD card Disable to access		Parameter Uploading
	Parameter Downloading		Trend graph function Running
	System Alarm Occurs		HART communication
	Process Alarm Occurs		Setting Alarm Occurs
	Warning Occurs		Information Occurs
	Display Damping Valid		Operation level: Operator
	Operation level: Maintenance		Operation level: Specialist

**(3) Data indication part**

Up to eight process values can be selected on the display. It is possible to display up to four items on the display at the same time, and the remaining four items can be displayed if scrolled.

**Table 2.2.1 Abbreviation table of process values to be indicated on the display**

Abbreviation	Description
FLP *1	Flow rate %
PRV *1	Process value
VEL *1	Flow velocity
VFL *1	Volumetric flow rate
MFL *1	Mass flow rate
FLB	Flow rate in % bar graph
CAL *1	Calorie (Only available for AXG, not for AXW)
TL1 *1	Totalized value 1
TL2 *1	Totalized value 2
TL3 *1	Totalized value 3
TAG	Tag No.
LTG	Long tag
COM	Communication protocol
ADH	Adhesion diagnostic level (Alarm at Level 4)
AO1 *1	Analog output value 1
AO2 *1	Analog output value 2
FNL	Flow level of flow noise diagnosis (Alarm at Level 4) (Only available for AXG, not for AXW)
TC1 *2	Total 1 count
TC2 *2	Total 2 count
TC3 *2	Total 3 count

\*1: A trend graph can be displayed online.

\*2: Available for Main soft rev (Main board revision/Main soft rev) R2.02.01 or later and Ind soft rev (Indicator board revision/Ind soft rev) R2.02.01 or later.

---

**NOTE**

---

The PRV (PV value) and FLP (flow rate%) operate in the same way as Analog output 1. If the low cut function is enable for Analog output 1 (AO1 low cut / Low cut), the PRV and FLP are affected by the low cut function. Their value after low cut are displayed. On the other hand, the VEL (flow velocity), VFL (volume flow), MFL (mass flow), and CAL (calorific value) are not affected by the low cut function. Their values are displayed as they are.

---

---

**NOTE**

---

If Main soft rev (Main board revision / Main soft rev) is R2.01.01 or earlier, the PRV (PV value), FLP (flow rate%), VEL (flow velocity), VFL (volume flow), MFL (mass flow), and CAL (calorific value) are not affected by the low cut function for analog output. Their values are displayed as they are.

---



## 2.2.2 Operation Level

When setting a parameter from the display, configurable parameters differ depending on the three operation levels shown in Table 2.2.2. For maintenance and specialist levels, the pass code needs to be entered.

**Table 2.2.2 Parameter Setting from Display and Operation Level**

Operation Level	Parameter		Description
	Reading	Writing	
Operator	All parameters	Possible to set a display language on the display and parameters related to display items.	No pass code required
Maintenance	All parameters	Possible to set parameters allowed to set with the operator level and parameters related to zero adjustment.	Pass code required Default value: 0000
Specialist	All parameters	Possible to set all writable parameters	Pass code required Default value: 0000

A pass code can be configured only from the display. This setting can be configured with the following parameters.

**Menu path**

<b>Display</b>	Device setup ► Detailed setup ► Access cfg ► (see below)
----------------	--

Parameter	Description
Chg mainte	Change of pass code (maintenance code) with maintenance operation level authority. To change the level, maintenance or specialist operation level authority is necessary.
Chg special	Change of pass code (special code) with specialist operation level authority. To change the level, specialist operation level authority is necessary.

## 2.3 Display Mode and Setting Mode

The device runs in Display Mode when the power is on. To check or change parameters, Setting Mode must be activated. The following procedure explains how to change to Setting Mode from Display Mode. For the functions of the IR switches, refer to Subsection 2.2.1.

**[Procedure]**

- 1) Keep touching [SET] switch for few seconds.

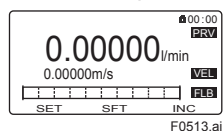

- 2) Touch [SFT] + [INC] switches.

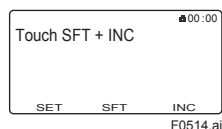

- 3) "No" is selected.  
Touch [INC] switch and select "Yes".

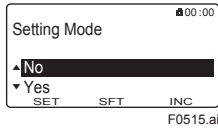

- 4) Touch [SET] switch.

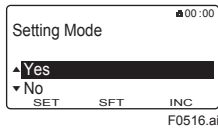

- 5) "Yes" is blinking.  
Touch [SET] switch again.

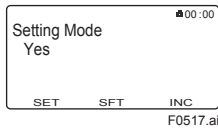

- 6) The screen moves to the menu of Operation Level.

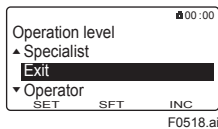

- 7) Select an appropriate operation level by moving the cursor with [INC] or [DEC] switch.  
Passcode is not necessary for "Operator". For "Maintenance" and "Specialist", passcode is necessary for each. For passcode setting, [SFT] is for position change, and [INC] is for number, then twice [SET] is for entry completion.  
The default passcode at the factory shipment is set to "0000".

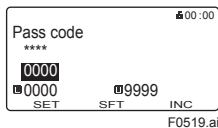

- 8) When the Operation Level is determined, the screen moves to "Device setup" as the Setting Mode where parameters can be configured.
- 9) After completing parameter setting, push [ESC] switch. The screen returns to the Display Mode.

**NOTE**

Follow the procedure bellow when Ind soft rev (Indicator board revision / Ind soft rev) is R2.01.02 or earlier.

**[Procedure]**

- 1) Turn on the power and wait for several seconds to start Display Mode.

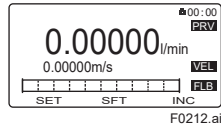

- 2) Press and hold the [SET] switch for two seconds. The screen will switch to the "Operation level" menu.

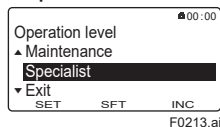

- 3) Select an appropriate operation level by moving the cursor with the [INC] or [DEC] switch. The "Operator" does not require a pass code, but for "Maintenance" and "Specialist", the pass code is necessary. When setting the pass code, [SFT] is for position change, [INC] is for number change, and pressing [SET] twice is for entry completion. The default pass code is set to "0000" when shipped from the factory.

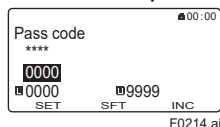

- 4) When the operation level is determined, the screen moves to "Device setup" and switches to Setting Mode. In Setting Mode, parameters can be configured.
- 5) After completing the parameter settings, press the [ESC] switch. The screen will return to Display Mode.

**IMPORTANT**

**Menu path**



When parameters on the menu described above are set in the Wizard of Easy setup, be sure to execute "Setting download" in each menu after setting the parameters. If "Setting download" is not executed, any changed parameters will not be correctly applied to the device.

**NOTE**

If there is no operation for 10 minutes in Setting Mode, the screen goes back to Display Mode.

### Parameter form

The following three parameter forms are available.

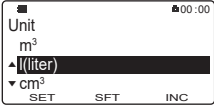
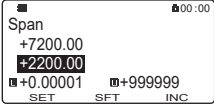
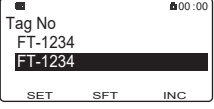
Type	Example of display	Description
Select type		Selects the adequate type of data from among the pre-determined alternatives.
Numeric type		Specifies the data with a combination of number and a decimal point for each digit.
Alphanumeric type		The data is configured with the combination of alphanumeric characters. (Tag No., Special unit, etc.)

The alphanumeric type displays the following alphanumeric characters in order.

0123456789ABCDEFGHIJKLMNOPQRSTUVWXYZabcdefghijklmnopqrstuvwxyz!#\$%&'()\*+,-./:;<=>?@  
 [ ] ^ \_ ` { } ~ "space"

## 2.4 Parameter Setting from Display Panel

This section explains how to specify the parameters from the display panel. Refer to Section 2.3, and set the operation level to “Specialist”. Also select a parameter to be specified in the Setting Mode.

### NOTE

The flow rate unit, span flow, and tag No. are explained as an example.  
If a particular parameters is specified at the time of ordering, this product is shipped with the parameter specified. If a parameter is not specified at the time of ordering, that parameter needs to be set by the customer.

### 2.4.1 Setting Example of Select Type Parameter (Flow rate unit)

The following is the procedure of changing the flow rate unit for the Select type parameter. The physical unit and time unit need to be specified individually for the flow rate unit. When setting the volumetric flow rate unit to l/min, set “l (liter)” to the physical unit and “/min” to the time unit.

This setting can be configured with the following parameters.

#### Menu path

<b>Display</b>	Device setup ▶ Detailed setup ▶ Pro var ▶ Volume ▶ (see below)
----------------	--

Parameter	Description
Unit	Specifies the physical unit of the volumetric flow rate.
Time unit	Specifies the time unit of the volumetric flow rate.

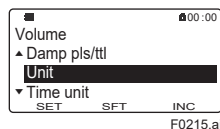

Specify the physical unit for volumetric flow rate. Move the cursor with [INC] and [DEC] according to the menu path described above, press [SET] to determine, and select the “Unit”.

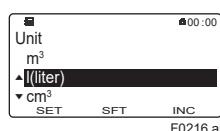

Move the cursor with [INC] and [DEC], press [SET] to determine, and select the “l(liter)”. While the selected unit is blinking, press [SET] to determine the unit. The screen returns to the setting page after completing the setting.

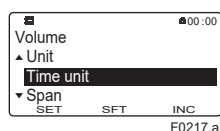

Specify the time unit for volumetric flow rate. Move the cursor with [INC] and [DEC] according to the menu path above, press [SET] to determine, and select the “Time unit”.

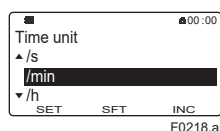

Move the cursor with [INC] and [DEC], select “/min”, and then press [SET]. While the selected unit is blinking, press [SET] to determine the unit. The screen returns to the setting page after completing the setting.

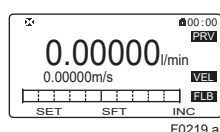

After completing the parameter setting, you can return the screen to Display Mode by pressing [ESC].

**NOTE**

Be sure to set the flow rate unit first when changing the flow rate unit and flow span value at the same time.  
 When the flow rate unit is changed, the span flow rate is converted in conjunction with the changed unit.

## 2.4.2 Setting Example of Numeric Type Parameter (Flow rate span)

The following is the procedure of changing the flow rate span as numeric type parameter. This setting can be configured with the following parameters.

**Menu path**

**Display** Device setup ▶ Detailed setup ▶ Pro var ▶ Volume ▶ Span

**NOTE**

Be sure to set the flow rate unit first when changing the flow rate unit and flow span value at the same time.  
 When the flow rate unit is changed, the span flow rate is converted in conjunction with the changed unit.

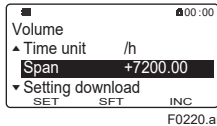

Specify the flow rate span unit.  
 Move the cursor with [INC] and [DEC] according to the menu path above, press [SET] to determine, and select the "Span".

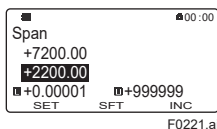

The switch's functionality for setting the span flow rate is as below:  
 Plus/minus and numeric change: [INC]  
 Movement of digits: [SFT]  
 Determination of parameter: [SET]  
 [ ]: Minimum value  
 [ ]: Maximum value  
 Press [SET] to determine the parameter while the setting value of the flow rate span is blinking. The screen returns to the setting page after completing the setting.

### 2.4.3 Setting Example of Alphanumeric Type Parameter (Tag No.)

The following is the procedure of changing the Tag No. of alphanumeric type parameter. This setting can be configured with the following parameters.

**Menu path**

**Display** | Device setup ▶ Detailed setup ▶ Device info ▶ Order info ▶ Tag No

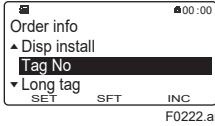

Specify the Tag No..  
Move the cursor with [INC] and [DEC] according to the menu path above, press [SET] to determine, and select the "Tag No".

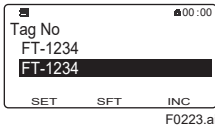

The Tag No. can be set with up to eight characters from the display.  
The switch's functionality for setting the Tag No. is as follows:  
Number and character change: [INC]  
Movement of digits: [SFT]  
Determination of parameter: [SET]  
Available characters: ASCII characters  
Press [SET] to determine the parameter while the value of Tag No. is blinking. The screen returns to the setting page after completing the setting.

## 2.5 microSD Card Insertion/Removal

If the optional code MC is selected, the parameter setting can be stored into the dedicated microSD card inserted into the display unit. The stored data can be restored to the device. For detailed on the functions, refer to Chapter 4.



### WARNING

Use only a microSD card designated by YOKOGAWA. The operation of the device cannot be guaranteed when other cards are used.

#### (1) Insertion of microSD Card

Carefully insert the dedicated microSD card into the slot on the display until the slot holds the card. (see Figure 2.5).

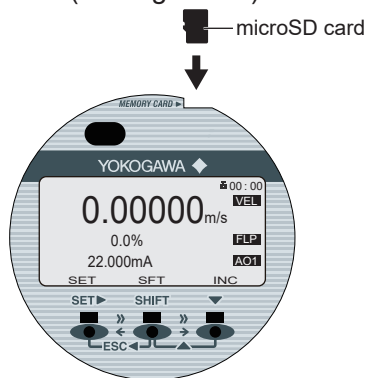

F0224.ai

Figure 2.5 Insertion of microSD Card

#### (2) Removal of microSD Card

Remove the microSD from the slot shown in Figure 2.5. When removing the microSD card, select “Execute” from the following parameters.

**Menu path**

<b>Display</b>	Device setup ▶ microSD ▶ Unmount
----------------	----------------------------------

### IMPORTANT

If the microSD card is removed without executing “Unmount” on the software, it may cause the stored data to be erased or the product to operate abnormally.



## 3. Operation with HART Configuration Tool

This chapter describes the connection of this product and HART configuration tool (FieldMate (Versatile Device Management Wizard)), and the operations using the HART configuration tool. Refer to the User's Manual of FieldMate (IM 01R01A01-01E) for details about FieldMate.

### NOTE

- For more details regarding the operations of the HART configuration tool, refer to the manual of the HART configuration tool.
- When using FieldMate as the HART configuration tool, be sure that the revision is R3.02.00 or later.

### NOTE

Parameters on the HART configuration tool are displayed in English only. Even if a language other than English is selected as "display language" on the display panel, parameters are displayed in English on the HART configuration tool.

### 3.1 Connecting HART Configuration Tool

The HART configuration tool can interface with this product from the control room, the device site, or any other wiring termination point in the loop, provided there is a minimum load resistance of  $230\ \Omega$  between the connection and the receiving instrument.

To communicate with the HART configuration tool, the HART configuration tool must be connected in parallel with this product. The connections must be non-polarized.

See Figure 3.1 for a connection example.

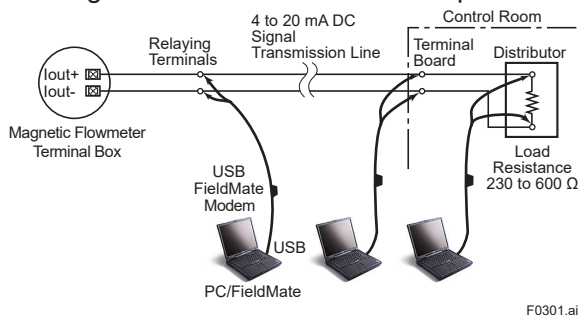

Figure 3.1 Connecting the HART Configuration Tool

### IMPORTANT

The communication signal is superimposed on an analog output signal during communication. It is recommended to set a low-pass filter (approximately 0.1s) to the receiver in order to reduce the output effect from the communication signal. Before online-communication, confirm that the communication signal does not affect the upper system.

## 3.2 HART Configuration Tool and Device Revision

### IMPORTANT

The protocol revision supported by the HART configuration tool must be the same as or later than the protocol revision of the product. If it is not, communication error will occur.

### 3.2.1 Device Description (DD) and Device Revision

Before using the HART configuration tool, confirm that the DD of this product is installed in the configuration tool. If the correct DD is not installed to the configuration tool, download the correct DD from the HART official site and install it, or contact the respective vendor of the configuration tool for its upgrade information.

The device revision is as follows.

DD Revision	1 or later
Device Type	AXG4A (0x371A) AXW4A (0x371B)
Device Revision	3

#### • Confirmation of DD revision

- (1) Turn on the power of this product with the configuration tool separated.
- (2) Confirm the device revision from the installed DD file name according to the procedure provided for the configuration tool.

The DD file name is four digits: the first two digits indicate the device revision and the latter two digits indicate the DD revision.

### NOTE

The device revision of the DD file is given in hexadecimal.

#### • Confirmation of Device revision

Connect the setting tool to this product and confirm the revision with the following parameter.

#### Menu path

<b>HART</b>	Device root menu ► Detailed setup ► Device information ► HART setup ► Fld dev rev
-------------	---

## 3.2.2 Device Type Manager (DTM) and Device Revision

When using FieldMate as the HART configuration tool, use the following DTM.

DTM Name	AXG4A FDT2.0 HART7 DTM AXW4A FDT2.0 HART7 DTM
DTM Revision	5.9.2.0 or later *
Device Type	AXG4A (0x371A) AXW4A (0x371B)
Device Revision	1, 3

\*: The DTM is included in Yokogawa DTM Library HART 8.2 or later.

### NOTE

The DTM revision can be confirmed with “DTM setup”.

Device Files is a medium included in FieldMate.

The user registration site provides Device Files with the latest update programs.

(URL: <https://partner.yokogawa.com/global/fieldmate/>)

When updating DTM, the following operations with “DTM setup” are required.

- Update DTM catalog
- Register DTM to the supported device.

For details, refer to the User’s Manual of FieldMate.

### 3.3 Basic Setup

If the dedicated parameters are specified at the time of ordering, this product is shipped with the Tag No. or device information configured.  
 The Tag No. and device information can be checked and set with the following parameters.

#### ■ Tag No. (Tag, Long tag)

Menu path

<b>HART</b>	Device root menu ▶ Detailed setup ▶ Device information ▶ Order information ▶ (see below)
-------------	--

Parameter	Description
Tag	Up to 8 alphanumeric characters *1
Long tag	Up to 32 alphanumeric characters *2

#### ■ Device information (Descriptor, Message, Date)

Menu path

<b>HART</b>	Device root menu ▶ Detailed setup ▶ Device information ▶ HART setup ▶ (see below)
-------------	---

Parameter	Description
Descriptor	Up to 16 alphanumeric characters *1
Message	Up to 32 alphanumeric characters *1
Date	Display format: mm/dd/yyyy mm = month (2 digits), dd = days (2 digits), yyyy = year (4 digits)

\*1: Symbols, letters and numbers enclosed by the thick line in the following table are available.

\*2: All symbols, letters and numbers in the following table are available.

SP	!	"	#	\$	%	&	'	(	)	*	+	,	-	.	/
0	1	2	3	4	5	6	7	8	9	:	;	<	=	>	?
@	A	B	C	D	E	F	G	H	I	J	K	L	M	N	O
P	Q	R	S	T	U	V	W	X	Y	Z	[	\	]	^	_
`	a	b	c	d	e	f	g	h	i	j	k	l	m	n	o
p	q	r	s	t	u	v	w	x	y	z	{		}	~	

\* "SP" indicates a space.

---

## 3.4 Parameter Configuration

The parameter structure of the HART configuration tool is hierarchical and various settings are available. For details of the menu tree and parameter, refer to Chapters 4 and 5. Note that some display parameters are different from those of the HART configuration tools.



### CAUTION

---

Note that a parameter cannot be set with the display while communicating with the HART configuration tool.

---

## 3.5 Data Renewing and Upload/Download Function

### (1) Data Renewing

The data is automatically updated at 0.5 to 2-second cycles.

### (2) Upload/Download Function

The upload function is used for copying the parameters of the product to the HART configuration tool. The download function is used for setting the copied parameters in the HART configuration tool into another product. The applicable parameters are included in “Upload variables” as follows.

Menu path

<b>HART</b>	Upload variables ► (see below)
-------------	--------------------------------

Tag	Total1 options	Display select7
Long tag	Total1 Start/Stop	Display select8
Descriptor	Total1 preset value	Trend select 1
Message	Total1 set point	Trend select 2
Date	Total1 count unit	Trend select 3
Final asbly num	Total2 unit	Trend select 4
Distributor	Total2 conv factor	Display format PV
Model	Total2 low cut	Display format total 1
Dev id	Total2 fail opts	Display format total 2
Poll addr	Total2 options	Display format total 3
PV is	Total2 Start/Stop	Display contrast
SV is	Total2 preset value	Display line
TV is	Total2 set point	Display period
QV is	Total2 count unit	Display NE107
Alarm record mask 1	Total3 unit	Display alarm
Alarm record mask 2	Total3 conv factor	Display scroll
Alarm record mask 3	Total3 low cut	Display damping
Alarm out mask 1	Total3 fail opts	Display format date
Alarm out mask 2	Total3 options	Display inversion
Alarm out mask 3	Total3 Start/Stop	Language
Alarm out mask 4	Total3 preset value	Display measure mode
Low alarm*1	Total3 set point	Display installation
Low low alarm*1	Total3 count unit	IRSW operation
High alarm*1	Totalizer reset mode	Display time
High high alarm*1	Pulse1 output mode	VF target select
Hi/Lo alarm hysteresis	Pulse1 active mode	Diagnostic output
PV flow select	Pulse1 fix width	VF mode
Velocity check	Pulse1 rate unit	VF No
Velocity unit	Pulse1 rate value	Electrode size
Velocity span	Pulse1 low cut	Explosion protection
Velocity damping AO/frequency	Pulse1 alarm out	Basic model code
Velocity damping pulse/total	Frequency1 at 0%	Suffix config 1
Time unit	Frequency1 at 100%	Suffix config 2
Volume flow unit	Status output1 function	Option 1
Volume flow span	Pulse1 option	Option 2
Volume flow damping AO/frequency	Loop current mode	Option 3
Volume flow damping pulse/total	AO1 low cut*1	Option 4
Mass flow unit	AO1 high limit	Remote sensor basic model code
Mass flow span	AO1 low limit	Remote sensor suffix config 1
Mass flow damping AO/frequency	AO1 alarm out	Remote sensor suffix config 2
Mass flow damping pulse/total	AO1 range mode	Remote sensor option 1
Density unit	Forward span 2*1	Remote sensor option 2
Density fixed value	Reverse span 1*1	Remote sensor option 3
Nominal size unit	Auto range hyst	Remote sensor option 4
Nominal size	Bi direction hyst	Process applied to the primary variable is outside the operating limits of the field device
User span select AO1	Flow direction	Process applied to the non-primary variable is outside the operating limits of the field device
User unit AO1	Display select1	PV Analog Channel Saturated
User span AO1	Display select2	PV Analog Channel Fixed
Total1 unit	Display select3	Field device has more status available
Total1 conv factor	Display select4	A reset or self test of the field device has occurred, or power has been removed and reapplied
Total1 low cut*1	Display select5	A modification has been made to the configuration of the field device
Total1 fail opts	Display select6	Field device has malfunctioned due to a hardware error or failure

\*1: This parameter is not displayed with FDT2.0 DTM. It is displayed only with HART built-in DTM.

Menu path

<b>HART</b>	Upload variables ► (see below)
-------------	--------------------------------

10:Main board CPU failure	Critical Power Failure	72:Data logging not started
11:Reverse calculation failure	Failure	80:Analog output 1 saturated
12:Main board EEPROM failure	Out of Specification	81:Analog output 2 saturated
13:Main board EEPROM default	Function Check	82:Pulse output 1 saturated
14:Sensor board failure	Simulation Active	83:Pulse output 2 saturated
15:Sensor communication error	Non-Volatile memory failure	84:Analog input saturated
16:A/D1 failure[Signal]	Volatile memory error	85:Cable misconnect
17:A/D2 failure[Exciter]	Watchdog reset executed	86:Coil insulation warning
18:Coil open	Voltage conditions out of range	131:Transmitter type mismatch
19:Coil short	Environmental conditions out of range	87:Adhesion over level 3
20:Exciter failure	Electronic failure	88:Low conductivity warning
21:PWM1 stop	Device Configuration Locked	89:Insulation detection
22:PWM2 stop	Status Simulation Active	90:Flow noise over level 3
23:Option board mismatch	Discrete Variable Simulation active	91:Flow noise over level 4
24:Option board EEPROM failure	Event Notification Overflow	92:Autozero warning
25:Option board A/D failure	Secondary Analog Channel Saturated	93:Verification warning
26:Option board SPI failure	Tertiary Analog Channel Saturated	94:Factory noise warning
27:Parameter restore incomplete	Quaternary Analog Channel Saturated	95:Simulation active
28:Indicator board failure	Quinary Analog Channel Saturated	96:Analog output 1 fixed
29:Indicator board EEPROM failure	Subdevice list changed	97:Analog output 2 fixed
30:LCD driver failure	Duplicate master detected	98:Pulse output 1 fixed
31:Indicator board mismatch	Subdevice mismatch	99:Pulse output 2 fixed
32:Indicator communication error	Subdevice with duplicate IDs found	100:Analog input fixed
33:microSD card failure	Stale data notice	101:Parameter restore running
50:Signal overflow	Capacity Denied	102:Display over warning
51:Empty pipe detection	Bandwidth allocation pending	103:microSD card size warning
52:H/L or HH/LL alarm	Block transfer pending	104:Parameter backup incomplete
53:Adhesion over level 4	Radio failure	105:microSD card mismatch
60:Span configuration error	Secondary Analog Channel Fixed	106:microSD card removal procedure error
61:PV flow select configuration error	Tertiary Analog Channel Fixed	120:Watchdog
62:Analog output 1 4-20mA limit error	Quaternary Analog Channel Fixed	121:Power off
63:Analog output 2 4-20mA limit error	Quinary Analog Channel Fixed	122:Instant power failure
64:Analog output 1 multi range error	67:Pulse output 1 configuration error	123:Parameter backup running
65:H/L HH/LL configuration error	68:Pulse output 2 configuration error	124:Data logging running
66:Density configuration error	69:Nominal size configuration error	130:Device ID not entered
Maintenance required	70:Adhesion configuration error	
Device variable alert	71:Flow noise configuration error	

## 3.6 Specific Functions of HART Configuration Tool

### 3.6.1 Process Variable Setting (Dynamic Variables)

The process variable to be assigned to PV (Primary Variable), SV (Secondary Variable), TV (Tertiary Variable) and QV (Quaternary Variable) can be selected.

Dynamic Variable	Selection	Default Value
PV	Velocity, Volume flow, Mass flow, Flow noise*	Volume flow
SV	"Velocity, Volume flow, Mass flow, Flow noise*, Calorific value*, Totalizer 1, Totalizer 2, Totalizer 3"	Totalizer 1
TV		Totalizer 2
QV		Totalizer 3

\*: Only available for AXG, not for AXW

This setting can be configured with the following method.

#### Menu path

<b>HART</b>	Process variables root menu ► Dynamic variables ► Change PV...QV map
-------------	--



### 3.6.2 Burst Mode

**(1) Applicable parameter of burst mode**

When the burst mode is enabled, the product continuously sends up to three data via HART communication. Also, it is possible to continuously send an alarm signal when a change to the product settings or a change by the self diagnosis is detected.

**NOTE**

When changing the setting of the burst mode, set the Burst mode to “Off”.

Command Parameter	Burst Command	Burst Message Trigger Mode	Burst Trigger Source	Burst Trigger Units
PV	Cmd1: PV	Continuous	---	---
		Window	PV	Depends on the assigned variable to PV
		Rising		
		Falling		
		On-change		
Loop Current and Percent Range	Cmd2: % range/ current	Continuous	---	
		Window	% range	%
		Rising		
		Falling		
		On-change		
PV, SV, TV, QV	Cmd3: Dyn vars/ current	Continuous	---	
		Window	PV	Depends on the assigned variable to PV
		Rising		
		Falling		
		On-change		
Device Variable with status	Cmd9: Device vars w/ status	Continuous	---	
		Window	Process variable assigned to the top of Burst Device Variables	Depends on the assigned variable to Burst Device Variables
		Rising		
		Falling		
		On-change		
Device Variable	Cmd33: Device variables	Continuous	---	
		Window	Process variable assigned to the top of Burst Device Variables	Depends on the assigned variable to Burst Device Variables
		Rising		
		Falling		
		On-change		
Additional Device Status	Cmd48: Read Additional Device Status	Continuous	---	
		On-change	All status	---

**(2) Burst mode setting**

Burst Mode can be specified in Easy Burst Mode or Detailed Burst Mode.

**• Setting Easy Burst Mode**

Easy Burst Mode can send one Burst Command continuously. Easy Burst Mode (BM0: Burst Message 0) can be configured with the following parameters.

**Menu path**

<b>HART</b>	Device root menu ► Detailed setup ► Device information ► HART setup ► Burst setup ► Easy burst setup ► set Easy Burst
-------------	---

**NOTE**

When Easy Burst Mode is used, Event Notification cannot be used.

**• Setting Detailed Burst Mode**

Detailed Burst Mode can send up to three Burst Commands continuously under various conditions. Detailed Burst Mode can be configured with the following parameters.

**Menu path**

<b>HART</b>	Device root menu ► Detailed setup ► Device information ► HART setup ► Burst setup ► Detailed burst setup ► (see below)
-------------	--

Parameter	Description
BM1 Setting ► set Detailed Burst	Detailed Burst Mode Settings (BM1: Burst Message 1)
BM2 Setting ► set Detailed Burst	Detailed Burst Mode Settings (BM2: Burst Message 2)
BM3 Setting ► set Detailed Burst	Detailed Burst Mode Settings (BM3: Burst Message 3)

In accordance with the method, specify the following.

- Burst Command
- Update Period/Max Update Period
- Burst Message Trigger Mode

**(3) Burst Command Setting**

Select the transmission data from the Burst Command.

Burst Command	Command Parameter
Cmd1:PV	PV
Cmd2:% range/current	Loop Current and Percent Range
Cmd3:Dyn vars/current	PV, SV, TV, QV
Cmd9: Device vars w/ status	Device Variable with status
Cmd33:Device Variables	Device Variable
Cmd48:Read Additional Device Status	Additional Device Status

**(4) Burst Device Variables Setting**

When “Cmd9: When Device vars w/ status” or “Cmd33:Device Variables” is selected as Burst Command, it is required to specify the Burst Device Variables, for which up to eight values for AXG, six values for AXW can be specified.

Dev Var Code	Burst Device Variables	Dev Var Code	Burst Device Variables
0	Velocity	4	Totalizer 2
1	Volume flow	5	Totalizer 3
2	Mass flow	6*	Flow noise
3	Totalizer1	7*	Calorific value

\* Only available for AXG, not for AXW

**(5) Update Period/Max Update Period Setting**

Specify the Update Period/Max Update Period, which is the update period of Burst Message Trigger Mode. The Burst Trigger Source is checked with the period of the Update Period, and if it fulfills the conditions of Burst Message Trigger Mode, the data will be updated. When it does not fulfill the conditions of the Trigger Mode with the period of the Update Period and reaches the Max Update Period, the data will be updated forcibly.

The Update Period/Max Update Period needs to be selected from the following.

Update Period/Max Update Period	
0.5 s	8 s
1 s	16 s
2 s	32 s
4 s	60 s to 3600 s (any value)

**NOTE**

For the Update Period, specify a value smaller than the Max Update Period.

**(6) Burst Message Trigger Mode Setting**

Specify Burst Message Trigger Mode. When “Window”, “Rising”, or “Falling” is set, the Burst Trigger Level must be specified.

Burst Message Trigger Mode	Description
Continuous	Burst Messages are transmitted continuously.
Window	Burst Trigger Level is the amount of change. The device variable value detects and transmits the amount of change.
Rising	The setting value of the Burst Trigger Level is the high limit value. When the device variable value exceeds the high limit value, it is detected, and a message is transmitted.
Falling	The setting value of the Burst Trigger Level is the low limit value. The device variable value detects and transmits that the low limit value is surpassed.
On-change	When the device variable value is changed from the previous output, it is detected, and a message is transmitted.

### 3.6.3 Event Notification

Changes to the device settings and changes in the device status by self diagnosis can be detected as events, sending continuous alarm signals. Up to five events can be stored as the history. When Event Notification is used, the Detailed Burst Message must be specified and the Burst Message must be enabled.

#### NOTE

Note that events stored as the history are deleted if the power is turned off.

#### (1) Event Notification Setting

The Event Notification can be configured with the following parameters.

##### Menu path

<b>HART</b>	Device root menu ► Detailed setup ► Device information ► HART setup ► Event setup ► (see below)
-------------	---

Parameter	Description
set Event	Specifies Event Notification.
stop Event	Specifies stopping Event Notification.

Select an Event Notification configuration from the table below.

Selection	Description
Event Mask	Specifies device status to detect an event (Event Mask) (Cmd48: Read Additional Device Status)
Event Notification Retry Time	Specifies the period of Event Notification when an event occurs.
Max Update Time	Specifies the period of Event Notification when an event has not occurred.
Event Debounce Interval	Specifies the minimum time that an event continues.

#### (2) Event Acknowledgment

If an Event is occurring, it must be acknowledged.

Acknowledgment of an event can be configured with the following parameter.

##### Menu path

<b>HART</b>	Device root menu ► Detailed setup ► Device information ► HART setup ► Event setup ► acknowledge Event
-------------	---

#### NOTE

Only the event which occurs first can be acknowledged. When multiple events occur, they must all be acknowledged.

#### (3) Event Notification Flow

When Event Notification is enabled, a status change caused by the self diagnosis of the product will activate the alarm Event1. Event1 is continuously transmitted in the cycle of Event Notification Retry Time.

If Event2 occurs before Event1 is acknowledged, the information on Event2 is stored internally and continuously transmitted until Event1 is acknowledged. When Event1 is acknowledged, Event1 disappears and Event2 is continuously transmitted until it is acknowledged. When Event2 is acknowledged, all Events are acknowledged, and are continuously transmitted at the interval of the Max Update Time.

### 3.6.4 Multidrop Mode

When Multidrop is enabled, the product can refer to the connection of HART communication devices on one communication transmission line. This product can connect up to 63 devices. To activate Multidrop Mode, a number from 1 to 63 must be assigned to the polling address. When Multidrop Mode is activated, analog output signal settings of 4 to 20 mA must be changed because all the data is transmitted digitally. Multidrop Mode can be configured with the following procedures.

#### (1) Polling Address Setting

Assign a number from 1 to 63 to the polling address. The polling address can be configured with the following parameter.

**Menu path**

<b>HART</b>	Device root menu ▶ Detailed setup ▶ Device information ▶ HART setup ▶ Poll addr
-------------	---

#### NOTE

When the same polling address is set for two or more devices in the Multidrop Mode, communication with these devices is disabled.

#### (2) Analog Output Setting

Usually, the analog output of Multidrop Mode should be fixed at 4 mA on the product side. However, it becomes impossible to use a burnout output if the analog output is fixed at 4 mA. In the case of applications which receive and operate the analog output signal, only one variable analog output signal can be set per loop. The analog output of Multidrop Mode can be configured with the following parameter.

**Menu path**

<b>HART</b>	Device root menu ▶ Detailed setup ▶ Device information ▶ HART setup ▶ Loop current mode
-------------	---

Select the analog output of multi-drop mode from the table below.

Selection	Description
Disabled	Specifies analog output to 4mA (fixed).
Enabled	Specifies analog output to 4 to 20 mA (variable).

#### NOTE

The analog output signal which is fixed in Multidrop Mode is applied only to analog output 1.

**(3) Enabling Multidrop Mode**

Refer to the User's Manual of the HART configuration tool when configuring the settings of polling for the receiving instrument.

**(4) Communication in Multidrop Mode**

- When connection between the device and the HART configuration tool starts, the tool searches for the device set to Multidrop Mode, and the polling address and tag are displayed.
- After the desired device is selected, normal communication with the selected device becomes possible. However, communication in Multidrop Mode is slower.

**(5) Release of Multidrop Mode**

To reset the Multidrop Mode, the parameter needs to be configured as below.

- Specify the polling address of (1) to "0".
- Specify the analog output of (2) to "Enabled".

# 4. Functions

This chapter describes the functions of the product. Following is an overview of each function.

## ■ Basic settings

This product can measure the process values of the flow velocity, volumetric flow rate, mass flow rate, calorie, and flow noise at the same time. A damping time constant can be specified for each process value.

For details about how to check measured results and the setting procedure, refer to Section 4.1.

## ■ Totalization function

This product has three totalizers for totalizing selected process values. In addition to the totalized value display function, the product has a totalization counter function to scale totalized values with the conversion factor and to count a specific flow rate. The product also has a totalization switch function that compares a specified target value with a totalized value to output the result in the form of the status output, and a totalization preset function that totalization starts from a value set in advance.

For details about the totalization function and setting procedures, refer to Section 4.2.

## ■ Pulse output, Frequency output, and Status output

A measurement result can be output as pulse output, frequency output, or status output. When a pulse output is used, the pulse width or pulse rate can be selected. When a frequency output is used, outputs at 0% and 100% for the span of the process value can be specified. When a status output is used, the product status can be output as a status output. For both pulse output and frequency output, the low-cut values can be set.

For details about each output and the setting procedure, refer to Section 4.3.

## ■ Status input

Since this product has a status input terminal, the totalizer preset function and zero adjustment function, etc. can be used in response to the status input from the outside. For details about the setting procedure of these functions, refer to Section 4.4.

## ■ Analog output/Analog input

Up to two analog outputs (one analog output for AXW) are available. The high/low limit function, forward/reverse flow rate function (reverse flow rate: 4 to 12 mA, forward flow rate: 12 to 20 mA), alarm output function, low-cut function and other functions are available.

Analog input (only available for AXG) is useful for inputting fluid temperature via an external temperature transmitter.

For details about setting procedures for the analog output and analog input, refer to Section 4.5.

## ■ Multi range function

The multi range function makes it possible to measure a flow rate while switching multiple ranges. A range can be switched in response to a flow rate, flow direction, and status input.

For details about the multi range function, refer to Section 4.6.

## ■ Auxiliary calculation function

This function is used to calculate the temperature correction for density or calorie by inputting the temperature from an external device in the form of an analog input. The accuracy of mass flow rate measurement is improved by setting the temperature correction for density.

For details about the auxiliary calculation function, refer to Section 4.7.

## ■ Alarm

A detected error can be notified as an alarm or warning. This function can show the error status based in accordance with NAMUR NE107 to suit parameter settings. It is also possible to record alarms that occurred in the past in the history and mask unnecessary so that they are hidden on the display.

For details about contents and setting procedures, refer to Section 4.8.

## ■ Display

This display supports multiple languages for use on the display. This function can also show the time changes of the selected parameter in a trend graph on the display.

For details about display settings, refer to Section 4.9.

### NOTE

---

The language on the display is set to “English” as default at factory shipment. If necessary, refer to Subsection 4.9.1 to select the adequate language.

The menu pass of the display on this manual is set to “English”.

---

## ■ Device information

With this function, the parameters specified at the time of order, model code, and suffix code of this product can be checked on the display.

For details about how to check the device information, refer to Section 4.10.

## ■ Self-diagnostic function

The self-diagnostic function can be used to diagnose failures of the product or the process state. For example, this function is useful for diagnosing the health of the product by using the electrode adhesion detecting function, sensor empty check function, or verification function.

For details about the various self-diagnostic functions, refer to Section 4.11.

## ■ Test mode

With this mode, the process value and the value output from a connection terminal can be arbitrarily specified to test a response from the device.

For details about the test mode, refer to Section 4.12.

## ■ Backup, Restore, and Duplicate of Parameter

The backup function can store settings of the parameters into the built-in memory in the display. If the optional code MC is selected, setting parameters are stored in the microSD card supplied with this product in addition to the built-in memory in the display (display board).

The backup data can be used to restore settings of the product for which data is backed up or duplicate settings to another product.

For details about the backup, restore, and duplicate functions, refer to Section 4.13.

## ■ Software write protection function

A write protect can be changed using the hardware write protection switch and the parameter settings (software write protection).

For details about the hardware write protection switch, refer to the Installation Manual. For details about the software write protection function, refer to Section 4.14.



# 4.1 Basic Settings

## 4.1.1 Overview

This product can measure flow velocity, volumetric flow rate, mass flow rate, calorie, and flow noise at the same time. A measured result can be output as an analog output, frequency output, pulse output, and status output.

Refer to the table below for codes and connection terminals of communication/input-output and input and output for each terminal.

Communication and I/O Code		Connection Terminal			
		I/O 1	I/O 2	I/O 3	I/O 4
JA	E	Iout1 Active	P/Sout1 Passive	—	—
JB*				P/Sout2 Passive	Iout2 Active
JC*				Sin (No-voltage)	Iout2 Active
JD*				Sout Passive	P/Sout2 Passive
JE	J			Sin (No-voltage)	P/Sout2 Passive
JF*				Sin (No-voltage)	P/Sout2 Active (with internal resistor)
JG	L			Sin (No-voltage)	P/Sout2 Active (without internal resistor)
JH*				Iout2 Passive	Iin Active
JJ*				P/Sout2 Passive	Iin Active
JK*				Sin (No-voltage)	Iin Active
JP*		Iout1 Passive	P/Sout1 Passive	—	
JQ*				Iout2 Passive	P/Sout2 Passive
JR*			P/Sout1 Passive (NAMUR)	—	
JS*				Iout2 Passive	P/Sout2 Passive (NAMUR)
JT*			P/Sout1 Passive	—	

Iout1: Analog output 1 (HART communication signal superimposed)

Iout2: Analog output 2

Iin: Analog input

P/Sout1: Pulse/Status output 1

P/Sout2: Pulse/Status output 2

Sout: Status output

Sin: Status input

\*: Only available for AXG, not for AXW

The position of Communication and I/O code:

Integral type:

AXG □□□ - □□□□□□□□□□□□□□ - □■□□

AXW □□□ - □□□□□□□□□□□□□□ - □■□□

AXW □□□G - ■□□□□□ - □□□□ - □□□

Remote Transmitter:

AXG4A- □□□□□□■□□□

AXG4A- □□□□□□■□□□

### NOTE

Available functions vary depending on communication and I/O code specified at the time of order. Before using each function of this product, be sure to check the connection terminal function of the product with the table above.

### 4.1.2 PV Mapping of Process Value

The flow velocity, volumetric flow rate, mass flow rate, and flow noise can be mapped to the primary variable (PV).

This setting can be configured with the following parameters.

**Menu path**

<b>Display</b>	Device setup ► Detailed setup ► Pro var ► PV flow select
<b>HART</b>	Device root menu ► Detailed setup ► Process variables ► PV flow select

Selection		Description
Display	HART	
Velocity	Velocity	Specifies the flow velocity to the Primary Value.
Volume	Volume	Specifies the volumetric flow rate to the Primary Value.
Mass	Mass	Specifies the mass flow rate to the Primary Value.
Diag	Diag	Specifies the flow noise to the Primary Value. (Only available for AXG, not for AXW)

Setting example: If the volumetric flow rate is set to PV, and the volumetric flow rate span is set to 100 m<sup>3</sup>/h for use, set the parameters as follows.

- PV flow select="Volume"
- Volume flow unit="m<sup>3</sup>"
- Time unit="/h"
- Volume flow span="100.000"

Setting example: If the mass flow rate is set to PV, with the mass flow rate span being set to 10,000 kg/h and the density to 1000 kg/m<sup>3</sup> for use, set the parameters as follows.

- Density unit="kg/m<sup>3</sup>"
- Density fixed value="1000.000"
- PV flow select="Mass"
- Mass flow unit="kg"
- Time unit="/h"
- Mass flow span="10000.0"

### 4.1.3 Display of the Process Value

The flow velocity, volumetric flow rate, mass flow rate, totalized value, calorie, and flow noise can be checked with the following parameters.

#### ■ Flow rate (PV)

**Menu path**

<b>Display</b>	Device setup ► Process variables ► (see below)
<b>HART</b>	Process variables root menu ► (see below)

Parameter		Description
Display	HART	
-	Dynamic variables ► PV% rnge	Displays the percentage to the range for the process value set to the Primary Value.
Flow rate(%)	Device variables ► Disp flowrate%*	For Flow rate(%) / Disp flowrate%, it displays the value synchronized with analog output 1.
-	Dynamic variables ► PV	Displays the process value set to the Primary Value.
Flow rate	Device variables ► Disp flowrate*	For Flow rate / Disp flowrate, it displays the value synchronized with analog output 1.

\*: Available for Main soft rev (Main board revision/Main soft rev) R2.02.01 or later

**Example: When the high limit (AO1 high limit) is set to 20.3 mA;**

When analog output 1 is fixed to the high limit, Flow rate / Disp flowrate displays the fixed value because it is synchronized with analog output 1.

PV displays the actual measured value because it is not synchronized with the analog output 1.

When the analog output is fixed due to an alarm, these values behave in the same way as above.

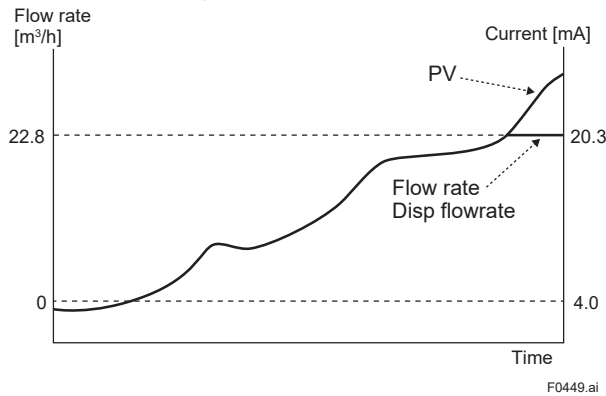

**NOTE**

If Main soft rev (Main board revision / Main soft rev) is R2.01.01 or earlier, Flow rate(%) and Flow rate on the display shows the actual value even if analog output is fixed.

For details about how to check the device revision (Main soft rev and Ind soft rev), refer to Subsection 4.10.2.

**■ Flow velocity, Volumetric flow rate, Mass flow rate, Totalized value, Calorie**

**Menu path**

<b>Display</b>	Device setup ▶ Process variables ▶ ( see below)
<b>HART</b>	Process variables root menu ▶ Device variables ▶ (see below)

Parameter		Description
Display	HART	
Velocity	Velocity	Displays the flow velocity.
Volume	Volume flow	Displays the volumetric flow rate.
Mass	Mass flow	Displays the mass flow rate.
Totalizer ▶ Totalizer 1	Totalizer1	Displays the totalized value of totalizer 1.
Totalizer ▶ Totalizer 2	Totalizer2	Displays the totalized value of totalizer 2.
Totalizer ▶ Totalizer 3	Totalizer3	Displays the totalized value of totalizer 3.
Calorie	Calorific value	Displays the calorie. (Only available for AXG, not for AXW)

**■ Flow noise**

**Menu path**

<b>Display</b>	Device setup ▶ Diag/Service ▶ Diagnosis ▶ Flow noise ▶ Result ▶ Value
<b>HART</b>	Process variables root menu ▶ Device variables ▶ Flow noise

This parameter is only available for AXG, not for AXW.

This parameter displays the flow noise.

### 4.1.4 Unit Setting

Units can be specified for the flow velocity, volumetric flow rate, mass flow rate, and calorie. Each flow rate unit can be specified with the physical unit and the time unit, individually. However, note that the time unit is common to all flow rates. Also, the unit of the flow noise is fixed to “cm/s” and it cannot be changed.

Example) To set the volumetric flow rate unit to “m<sup>3</sup>/h”

The volumetric unit can be set to “m<sup>3</sup>/h” and the time unit to “/h”. At this time, the time unit for the mass flow rate and calorie are also set to “/h”.

This setting can be configured with the following parameters.

#### ■ Physical unit

**Menu path**

<b>Display</b>	Device setup ▶ Detailed setup ▶ Pro var ▶ (see below)
<b>HART</b>	Device root menu ▶ Detailed setup ▶ Process variables ▶ (see below)

Parameter		Description
Display	HART	
Velocity ▶ Unit	Velocity ▶ Velocity unit	Specifies the physical unit of the flow velocity.
Volume ▶ Unit	Volume flow ▶ Volume flow unit	Specifies the physical unit of the volumetric flow rate.
Mass ▶ Unit	Mass flow ▶ Mass flow unit	Specifies the physical unit of the mass flow rate.
Calorie ▶ Unit	Calorie ▶ Calorific unit	Specifies the physical unit of the calorie. (Only available for AXG, not for AXW)

#### ■ Time unit

**Menu path**

<b>Display</b>	Device setup ▶ Detailed setup ▶ Pro var ▶ (see below)
<b>HART</b>	Device root menu ▶ Detailed setup ▶ Process variables ▶ (see below)

Parameter		Description
Display	HART	
Volume ▶ Time unit	Volume flow ▶ Time unit	Specifies the time unit of the volumetric flow rate.
Mass ▶ Time unit	Mass flow ▶ Time unit	Specifies the time unit of the mass flow rate.
Calorie ▶ Time unit	Calorie ▶ Time unit	Specifies the time unit of the calorie. (Only available for AXG, not for AXW)

## 4.1.5 Span Setting

A span can be specified for the flow velocity, volumetric flow rate, mass flow rate, calorie, and flow noise.

However, the unit for the span is the same as the unit specified in Subsection 4.1.4. If the unit is changed, the span value is converted to match the changed unit.

This setting can be configured with the following parameters.

### ■ Flow velocity, Volumetric flow rate, Mass flow rate, Calorie

**Menu path**

<b>Display</b>	Device setup ► Detailed setup ► Pro var ► (see below)
<b>HART</b>	Device root menu ► Detailed setup ► Process variables ► (see below)

Parameter		Description
Display	HART	
Velocity ► Span	Velocity ► Velocity span	Specifies the span of the flow velocity.
Volume ► Span	Volume flow ► Volume flow span	Specifies the span of volumetric flow rate.
Mass ► Span	Mass flow ► Mass flow span	Specifies the span of the mass flow rate.
Calorie ► Span	Calorie ► Calorific flow span	Specify the span of the calorie. (Only available for AXG, not for AXW)

### ■ Flow noise

**Menu path**

<b>Display</b>	Device setup ► Diag/Service ► Diagnosis ► Flow noise ► Span
<b>HART</b>	Diagnostic root menu ► Diagnosis ► Flow noise ► Flow noise span

This parameter is only available for AXG, not for AXW.

This parameter specifies the span of the flow noise.

#### NOTE

Be sure to note the following points when specifying the flow rate span.

- For a line with a significant flow change, set the maximum flow rate to the flow rate span. If the flow rate exceeds the flow rate span, the error of the flow rate% increases.
- For a line with a stable flow rate, set the flow rate span to approximately 1.5 to 2.0 times the normal flow rate.
- For flow rate span, set the value for which the flow velocity is comparable to the range from 0.3 to 10 m/s. The converted value to the flow velocity unit can be checked using the sizing data described in the general specifications or the parameter (Subsection 4.1.13). For the parameter in Subsection 4.1.13, it displays the value obtained by converting the specified flow rate span to the flow velocity unit.

#### NOTE

Be sure to set the flow rate unit first when the span value and its flow rate unit are changed at the same time.

**NOTE**

If Main soft rev (Main board revision/Main soft rev) is R2.02.02 or later, when the above span parameters are changed, a value equivalent to 3% of the changed span is automatically set to the Total/Pulse low cut parameters.

To set an arbitrary lowcut value, set the Total/Pulse low cut parameter after the above settings. If the Total/Pulse low cut parameter value is 0, the low cut parameter is not automatically set.

Example:

When changing the span from 50.0 m<sup>3</sup>/h to 100.0 m<sup>3</sup>/h, if Main board revision/Main soft rev is R2.02.01 or earlier, the Total/Pulse low cut value will remain the same as before the span change. In R2.02.02 or later, a value of 3.0 m<sup>3</sup>/h, which is equivalent to 3% of the changed span of 100.0 m<sup>3</sup>/h, is automatically set as the Total/Pulse low cut.

Volume flow span Parameter Change (When PV Flow Select is Volume)		Pulse1 low cut/Total1 low cut Behavior	
		(Main board revision/Main soft rev) R2.02.01 or earlier	(Main board revision/Main soft rev) R2.02.02 or later
Before Change	50.0 m <sup>3</sup> /h	1.5 m <sup>3</sup> /h	1.5 m <sup>3</sup> /h
After Change	100.0 m <sup>3</sup> /h	1.5 m <sup>3</sup> /h	3.0 m <sup>3</sup> /h

### 4.1.6 Damping Time Constant Setting

The damping time constant (63.2% response) can be specified for the flow velocity, volumetric flow rate, mass flow rate, calorie, and flow noise. To reduce an output fluctuation or change the response speed, change the damping time constant (default value is 3.0 seconds).

It is possible to measure a pulsing flow of up to 1 Hz with an output damping of 0.1 seconds for a piston pump, etc.

The damping time constant can be set for the output of each process value. The damping time constant is a common setting for the analog output, frequency output, pulse output, and totalized value. However, the damping setting for the flow noise is common to all outputs.

This setting can be configured with the following parameters.

#### ■ Analog output/Frequency output

Menu path

<b>Display</b>	Device setup ► Detailed setup ► Pro var ► (see below)
<b>HART</b>	Device root menu ► Detailed setup ► Process variables ► (see below)

Parameter		Description
Display	HART	
Velocity ► Damp AO/F	Velocity ► Velocity damping AO/frequency	Specifies the damping time constant of the flow velocity.
Volume ► Damp AO/F	Volume flow ► Volume flow damping AO/frequency	Specifies the damping time constant of the volumetric flow rate.
Mass ► Damp AO/F	Mass flow ► Mass flow damping AO/frequency	Specifies the damping time constant of the mass flow rate.
Calorie ► Damp AO/F	Calorie ► Calorific value damping AO/frequency	Specifies the damping time constant of the calorie. (Only available for AXG, not for AXW)

## ■ Pulse output/Totalizer

### Menu path

<b>Display</b>	Device setup ► Detailed setup ► Pro var ► (see below)
<b>HART</b>	Device root menu ► Detailed setup ► Process variables ► (see below)

Parameter		Description
Display	HART	
Velocity ► Damp pls/ttl	Velocity ► Velocity damping pulse/total	Specifies the damping time constant of the flow velocity.
Volume ► Damp pls/ttl	Volume flow ► Volume flow damping pulse/total	Specifies the damping time constant of the volumetric flow rate.
Mass ► Damp pls/ttl	Mass flow ► Mass flow damping pulse/total	Specifies the damping time constant of the mass flow rate.
Calorie ► Damp pls/ttl	Calorie ► Calorific value damping pulse/total	Specifies the damping time constant of the calorie. (Only available for AXG, not for AXW)

## ■ Flow noise

### Menu path

<b>Display</b>	Device setup ► Diag/Service ► Diagnosis ► Flow noise ► Damp
<b>HART</b>	Diagnostic root menu ► Diagnosis ► Flow noise ► Flow noise damping

This parameter is only available for AXG, not for AXW.

This parameter specifies the damping time constant of the flow noise.

### 4.1.7 Low-cut Function Setting

A low-cut value can be specified for the analog output, frequency output, pulse output, and totalizer output value.

If the low-cut function is used, the flow rate below set values can be stopped from being output.

This function helps reduce erroneous output when the flow is “0”.

However, the unit of the low-cut value is the same as the unit specified in Subsection 4.1.4. If the unit is changed, the low-cut value is changed to match the changed unit. The low-cut value is not synchronized with the span value. If the span value is changed, be sure to reset the low-cut value.

Set the low-cut value to “0” if the low-cut function is not used.

This setting can be configured with the following parameters.

## ■ Analog output

### Menu path

<b>Display</b>	Device setup ► Detailed setup ► Analog out/in ► (see below)
<b>HART</b>	Device root menu ► Detailed setup ► Analog output/input ► (see below)

Parameter		Description
Display	HART	
AO1 ► Low cut	Analog output 1 ► AO1 low cut	Specifies the low-cut value of analog output 1. If PV is set for the measurement screen on the display, a PV value which is low-cut with the value set here is displayed.
AO2 ► Low cut	Analog output 2 ► AO2 low cut	Specifies the low-cut value of analog output 2. (Only available for AXG, not for AXW)

## ■ Frequency output/Pulse output

### Menu path

<b>Display</b>	Device setup ► Detailed setup ► Pulse/Status out ► ( see below)
<b>HART</b>	Device root menu ► Detailed setup ► Pulse/Status ► (see below)

Parameter		Description
Display	HART	
PO1/SO1 ► Low cut	Pulse/Status output 1 ► Pulse1 low cut	Specifies the low-cut values of frequency output 1 and pulse output 1.
PO2/SO2 ► Low cut	Pulse/Status output 2 ► Pulse2 low cut	Specifies the low-cut values of frequency output 2 and pulse output 2.

## ■ Totalizer

### Menu path

<b>Display</b>	Device setup ► Detailed setup ► Totalizer ► (see below)
<b>HART</b>	Device root menu ► Detailed setup ► Totalizer ► (see below)

Parameter		Description
Display	HART	
Totalizer 1 ► Low cut	Totalizer1 ► Total1 low cut	Specifies the low-cut value of totalizer 1.
Totalizer 2 ► Low cut	Totalizer2 ► Total2 low cut	Specifies the low-cut value of totalizer 2.
Totalizer 3 ► Low cut	Totalizer3 ► Total3 low cut	Specifies the low-cut value of totalizer 3.

The actual value for which the low-cut is effective has  $\pm 0.5\%$  of the hysteresis from the set low-cut value. The hysteresis width on the negative side (going into the low-cut. When flow rate is decreasing) and the positive side (going out of low-cut. When flow rate is increasing) are as follows:

(1) Negative side

$$= \text{Low-cut set value} - (\text{Minimum span set with multi range} \times 0.5 \%)$$

(2) Positive side

$$= \text{Low-cut set value} + (\text{Minimum span set with multi range} \times 0.5 \%)$$

**Example: When setting to span of volumetric flow rate = 10.0 m<sup>3</sup>/h,  
Low-cut value = 1.0 m<sup>3</sup>/h**

(1) Negative side

$$= 1.0 \text{ [m}^3\text{/h]} - (10.0 \text{ [m}^3\text{/h]} \times 0.5 \%)$$

$$= 0.95 \text{ [m}^3\text{/h]}$$

(2) Positive side

$$= 1.0 \text{ [m}^3\text{/h]} + (10.0 \text{ [m}^3\text{/h]} \times 0.5 \%)$$

$$= 1.05 \text{ [m}^3\text{/h]}$$

In this case, when the flow rate is decreasing, the output flow rate value becomes 0.0 [m<sup>3</sup>/h] with the low-cut function if the actual flow rate goes below 0.95 [m<sup>3</sup>/h]. On the other hand, when the flow rate is increasing, the flow rate value is output if the actual flow rate goes over 1.05 [m<sup>3</sup>/h].



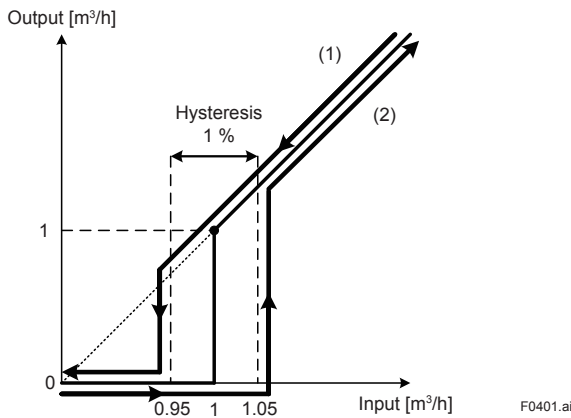

**NOTE**

Note that the totalization might be counted due to the influence of the output fluctuation near 0% output if a small low-cut value is set. In particular, if the value of the flow rate span, damping time constant, or conductivity is low, the totalization is easily counted when the flow rate is “0”. In such a case, increase the flow rate span, damping time constant, or low-cut value.

**NOTE**

When changing the output process value to be output, it is necessary to specify the low-cut value again.

**NOTE**

If Main soft rev (Main board revision/Main soft rev) is R2.02.02 or later, and if the Forward/Reverse flow rate function is switched between enabled and disabled by changing the Pulse/Status output mode and Status output function, or if changing the span parameter settings, a value equivalent to 3% of the span is automatically set to the Total/Pulse low cut parameters. When setting arbitrary values for the low cut parameters, set the Total/Pulse low cut parameters after setting these parameters. If the Total/Pulse low cut parameter value is 0, the low cut parameter is not automatically set.

Example:

When changing the span from 50.0 m³/h to 100.0 m³/h, if Main board revision/Main soft rev is R2.02.01 or earlier, the Total/Pulse low cut value will remain the same as before the span change. In R2.02.02 or later, a value of 3.0 m³/h, which is equivalent to 3% of the changed span of 100.0 m³/h, is automatically set as the Total/Pulse low cut.

Volume flow span Parameter Change (When PV Flow Select is Volume)		Pulse1 low cut/Total1 low cut Behavior	
		(Main board revision/Main soft rev) R2.02.01 or earlier	(Main board revision/Main soft rev) R2.02.02 or later
Before Change	50.0 m³/h	1.5 m³/h	1.5 m³/h
After Change	100.0 m³/h	1.5 m³/h	3.0 m³/h

### 4.1.8 Meter Factor Setting

When ordering only the remote transmitter, or when changing the remote sensor to combine with, the meter factor of the remote sensor must be specified.

This setting can be configured with the following parameters.

When the customer orders the remote transmitter and the remote sensor at the same time as a combination, the meter factor of the remote sensor to combine with is set to the remote transmitter. So, the customer is not required to set the meter factor.

**Menu path**

<b>Display</b>	Device setup ▶ Detailed setup ▶ Sensor ▶ (see below)
<b>HART</b>	Device root menu ▶ Basic setup ▶ Sensor ▶ (see below)

Parameter		Description
Display	HART	
Low MF	Low MF	Specifies the meter factor of the low-frequency side.
High MF	High MF	Specifies the meter factor of the high-frequency side.

**NOTE**

The meter factor is described in the METER FACTOR column on the remote sensor nameplate.

**Example:**

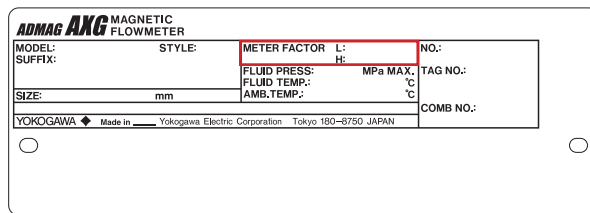

F0445.ai

## 4.1.9 Sensor Type Setting

When only the remote transmitter is ordered, or when the remote sensor to combine with, the type of the remote sensor must be specified.

This setting can be configured with the following parameters.

When the customer orders the remote transmitter and the remote sensor at the same time as a combination, the type of the remote sensor to combine with is set to the remote transmitter at the factory before shipment. So, the customer is not required to set the sensor type.

### Menu path

<b>Display</b>	Device setup ► Detailed setup ► Sensor ► Flow sensor sel
<b>HART</b>	Device root menu ► Basic setup ► Sensor ► Flow sensor select

From the table below, select the sensor type.

Selection		Description
Display	HART	
ADMAG AXG	ADMAG AXG	Configure to use the ADMAG AXG Series remote sensor. (Only available for AXG, not for AXW)
ADMAG AXW	ADMAG AXW	Configure to use the ADMAG AXW Series remote sensor.
ADMAG AXF	ADMAG AXF	Configure to use the ADMAG AXF Series remote sensor. (Only available for AXG, not for AXW)
ADMAG AE	ADMAG AE	Configure to use the ADMAG AE Series remote sensor. (Only available for AXG, not for AXW)
Calibrator	Calibrator	Configure to use the AM012 (calibrator) .
Other 1	Other1	Configure to use another remote sensor.
Other 2	Other2	
Other 3	Other3	

## IMPORTANT

When changing the combination of the sensors, the meter factor needs to be re-adjusted based on actual flow calibration to secure the accuracy. When using another remote sensor, such as other companies' products, contact a Yokogawa sales office or representative.

### 4.1.10 Sensor's Nominal Size Setting

When only the remote transmitter is ordered, or when changing the remote sensor to combine, the nominal size of the remote sensor must be specified.

This setting can be configured with the following parameters.

When the customer orders the remote transmitter and the remote sensor at the same time as a combination, the nominal size of the remote sensor to combine with is set to the remote transmitter at the factory before shipment. So, the customer is not required to set the nominal size.

**Menu path**

<b>Display</b>	Device setup ► Detailed setup ► Sensor ► (see below)
<b>HART</b>	Device root menu ► Detailed setup ► Sensor ► (see below)

Parameter		Description
Display	HART	
Nominal size unit	Nominal size unit	Specifies the unit of the nominal size.
Nominal size	Nominal size	Specifies nominal size.

**NOTE**

For the integral type, the nominal size and its unit have been set at the factory shipment. Do not change the these parameters.

### 4.1.11 Density Setting

The density must be set in order to measure the mass flow rate. The density can be selected from the density compensated with fixed density or density corrected by temperature.

For details about how to measure the mass flow rate or correct the density by temperature, refer to Subsection 4.7.5.

If density is set to "0" while the mass flow rate is mapped to PV, a setting error will result.

This setting can be configured with the following parameters.

**Menu path**

<b>Display</b>	Device setup ► Detailed setup ► Pro var ► Density ► (see below)
<b>HART</b>	Device root menu ► Detailed setup ► Process variables ► Density ► (see below)

Parameter		Description
Display	HART	
Value select	Density value select	Selects one of the following temperature-based density corrections. <ul style="list-style-type: none"> <li>• Fixed value: Uses the fixed density</li> <li>• Correction value: Uses the corrected density (Only available for AXG, not for AXW)</li> </ul>
Unit	Density unit	Specifies the unit of the density.
Fixed density	Density fixed value	Specifies the value of the fixed density.
Std density	Standard density	Specifies the reference density value of the standard condition to use the density compensated with temperature. (Only available for AXG, not for AXW)
Correct density	Correct density	Displays the corrected density. (Only available for AXG, not for AXW)

### 4.1.12 Temperature Setting

These parameters are only available for AXG, not for AXW.

The temperature setting is required when calculating the calorie based on this value's difference from the temperature that is input via the analog input process.

For details about the calorie calculation, refer to Subsection 4.7.6.

This setting can be configured with the following parameters.

**Menu path**

<b>Display</b>	Device setup ► Detailed setup ► Pro var ► Temperature ► (see below)
<b>HART</b>	Device root menu ► Detailed setup ► Process variables ► Temperature ► (see below)

Parameter		Description
Display	HART	
Std temperature	Standard temperature	Specifies the reference standard temperature for the temperature-based density correction function.
Meas temperature	Measured temperature	Displays the temperature that is input from analog input.
Fixed temperature	Calorific fix temp	Specifies the reference temperature for the calorie calculation with the temperature difference from the temperature which is input from analog input.

### 4.1.13 Span Flow Velocity Display

The span of the PV-mapped process value in Subsection 4.1.2 can be displayed in the flow velocity unit.

This information can be viewed with the following parameters.

**Menu path**

<b>Display</b>	Device setup ► Detailed setup ► Pro var ► Velocity check
<b>HART</b>	Device root menu ► Detailed setup ► Process variables ► Velocity check

### 4.1.14 User Span Function

The user span function can display a process value assigned to analog output 1 and analog output 2 with the customer's desired special unit. If the same process value is assigned to both analog outputs, the setting for analog output 1 takes precedence. This setting can be configured with the following parameters.

#### ■ Using user span

**Menu path**

<b>Display</b>	Device setup ► Detailed setup ► User Span ► (see below)
<b>HART</b>	Device root menu ► Basic setup ► User span ► (see below)

Parameter		Description
Display	HART	
User span AO1 ► Select	User span select AO1	Specifies the user span function to the process value allocated to analog output 1.
User span AO2 ► Select	User span select AO2	Specifies the user span function to the process value allocated to analog output 2. (Only available for AXG, not for AXW)

From the table below, select the user span function.

Selection		Description
Display	HART	
No	No	Not using user span function.
Yes	Yes	Using user span function.

#### ■ User unit setting

**Menu path**

<b>Display</b>	Device setup ► Detailed setup ► User Span ► (see below)
<b>HART</b>	Device root menu ► Basic setup ► User span ► (see below)

Parameter		Description
Display	HART	
User span AO1 ► Unit	User unit AO1	Specifies the desired unit of up to 8 characters to the process value assigned to analog output 1.
User span AO2 ► Unit	User unit AO2	Specifies the desired unit of up to 8 characters to the process value assigned to analog output 2. (Only available for AXG, not for AXW)

## ■ User span setting

### Menu path

<b>Display</b>	Device setup ► Detailed setup ► User Span ► (see below)
<b>HART</b>	Device root menu ► Basic setup ► User span ► (see below)

Parameter		Description
Display	HART	
User span AO1 ► Span	User span AO1	Specifies the desired span to the process value assigned to analog output 1.
User span AO2 ► Span	User span AO2	Specifies the desired span to the process value assigned to analog output 2. (Only available for AXG, not for AXW)

## IMPORTANT

The output in the user unit is displayed as follows:

Output in user unit = (Output in a physical unit of the process value / Span in a physical unit of the process value) × User span

### Example:

To set the span setting for analog output 1 to 100 dl/s, set the parameters as follows due to 100 dl = 10 L. Displays 100 dl/s when outputting 100 %.

PV = "Volume flow"

Span of volumetric flow rate = "10 l/s"

Using user span for analog output 1 = "Yes"

User unit for analog output 1 = "dl/s"

User span for analog output 1 = "100"

### 4.1.15 Zero Adjustment

The zero adjustment is carried out to set the output for zero flow velocity to 0% (4 mA). Although the adjustment to zero is performed at the manufacturing factory prior to shipment, this procedure must be carried out once again following the installation of piping to match the product to its operating conditions.

This subsection describes the zero adjustment procedure using the display.

#### IMPORTANT

- The zero adjustment should be carried out before the actual operation. Note that setting and updating other parameters cannot be carried out during the zero adjustment (for approximately 30 seconds).
- The zero adjustment should be executed only after the sensor is filled with measuring fluid and the fluid velocity is reduced to zero by closing the valve.
- Each time the measuring fluid is changed, be sure to perform the zero adjustment for that changed fluid.

#### ■ Execution of zero adjustment

Zero adjustment using the display can be executed with the following parameters.

##### Menu path

<b>Display</b>	Device setup ▶ Diag/Service ▶ Autozero ▶ Execute ▶ Execute
----------------	--

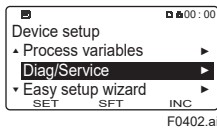

Select "Diag/Service" in accordance with the menu path above.

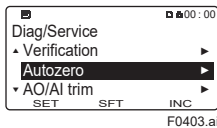

Select "Autozero".

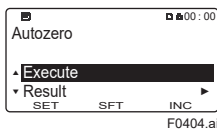

Select "Execute".

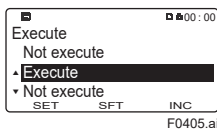

Select "Execute".

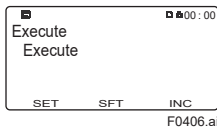

When "Execute" blinks, touch [SET] to execute.

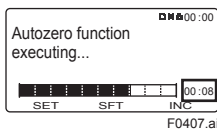

The zero adjustment starts, and the progress is displayed with the remaining time and a bar graph. Wait for the zero adjustment to complete.

← The time remaining until the end.



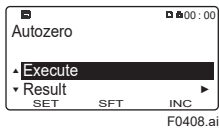

After the zero adjustment is finished, the display returns to “Autozero” menu.

Zero adjustment by HART communication can be executed with the following parameters.

**Menu path**

<b>HART</b>	Device root menu ▶ Basic setup ▶ Autozero ▶ Autozero Exe
-------------	--

## ■ Confirmation of zero adjustment result

The zero adjustment result using the display can be confirmed with the following parameters.

**Menu path**

<b>Display</b>	Device setup ▶ Diag/Service ▶ Autozero ▶ Result ▶ Zero value
----------------	--

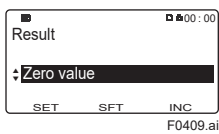

For the result of the zero adjustment, select “Result” and then “Zero value”.

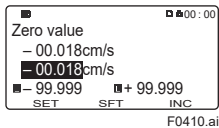

The result of zero adjustment is displayed as on the left of the screen.

## NOTE

When the zero adjustment result exceeds the defined value, the warning [092:AZ warn] is displayed.

The zero adjustment result using HART communication can be confirmed with the following parameters.

**Menu path**

<b>HART</b>	Device root menu ▶ Basic setup ▶ Autozero ▶ Zero value
-------------	--

## 4.2 Totalization Function

### 4.2.1 Totalized Value and Unit Setting

This function can totalize the volumetric flow rate, mass flow rate, and calorie. This product has three totalizers and can totalize 3 process values at the same time.

Totalizer 1 totalizes the values in the unit of the PV-mapped process value in Subsection 4.1.2.

Totalizers 2 and 3 totalize the process value of the selected unit.

This setting can be displayed and configured with the following parameters.

**Menu path**

<b>Display</b>	Device setup ► Detailed setup ► Totalizer ► (see below)
<b>HART</b>	Device root menu ► Detailed setup ► Totalizer ► (see below)

Parameter		Description
Display	HART	
Totalizer 1 ► Unit	Totalizer1 ► Total1 unit	Displays the unit of totalizer 1.
Totalizer 2 ► Unit	Totalizer2 ► Total2 unit	Specifies the unit of totalizer 2.
Totalizer 3 ► Unit	Totalizer3 ► Total3 unit	Specifies the unit of totalizer 3.

**NOTE**

The flow velocity and flow noise cannot be totalized. If flow velocity or flow noise is selected for the Primary Value, totalizer1 totalizes the volumetric flow rate and unit using “m<sup>3</sup>”.

### 4.2.2 Totalized Value Display and Totalization Function

The totalization result can be displayed with a totalized value or a totalized value which is scaled with the conversion factor (totalized count value). When the totalized value is scaled with the conversion factor, a specific flow rate is totalized in 1-count increments, which can be used as a totalizer counter. However, note that the conversion factor cannot be set to “0”.

If the totalized value on the display exceeds ±99999999, the maximum value of the displayed digits, the user can select whether to reset the displayed value to 0 or hold ±99999999.

The totalized value can be displayed and configured with the following parameters.

**■ Displaying totalized value**

**Menu path**

<b>Display</b>	Device setup ► Process variables ► Totalizer ► (see below)
<b>HART</b>	Process variables root menu ► Device variables ► (see below)

Parameter		Description
Display	HART	
Totalizer 1	Totalizer1	Displays the totalized value of totalizer 1.
Totalizer 2	Totalizer2	Displays the totalized value of totalizer 2.
Totalizer 3	Totalizer3	Displays the totalized value of totalizer 3.

## ■ Setting conversion factor for scaling

### Menu path

<b>Display</b>	Device setup ► Detailed setup ► Totalizer ► (see below)
<b>HART</b>	Device root menu ► Detailed setup ► Totalizer ► (see below)

Parameter		Description
Display	HART	
Totalizer 1 ► Conv factor	Totalizer1 ► Total1 conv factor	Specifies the conversion factor of totalizer 1.
Totalizer 2 ► Conv factor	Totalizer2 ► Total2 conv factor	Specifies the conversion factor of totalizer 2.
Totalizer 3 ► Conv factor	Totalizer3 ► Total3 conv factor	Specifies the conversion factor of totalizer 3.

## ■ Display of the totalized count value that is scaled with the conversion factor

### Menu path

<b>Display</b>	Device setup ► Process variables ► Totalizer ► (see below)
<b>HART</b>	Process variables root menu ► Totalizer count ► (see below)

Parameter		Description
Display	HART	
Totalizer 1 count	Totalizer1 count	Displays the scaled totalized value of totalizer 1.
Totalizer 2 count	Totalizer2 count	Displays the scaled totalized value of totalizer 2.
Totalizer 3 count	Totalizer3 count	Displays the scaled totalized value of totalizer 3.

### Example:

Set the unit of totalizer 2 to “m<sup>3</sup>” and the conversion factor to 2.

->If the totalized value of totalizer 2 is set to “10.123 m<sup>3</sup>”, the totalized value is scaled to “10.123÷2 = 5”.

## ■ Setting the user unit for the totalized count value scaled with the conversion factor

This function is available when Main soft rev (Main board revision/Main soft rev) is R2.02.01 or later and Ind soft rev (Indicator board revision/Ind soft rev) is R2.02.01 or later.

### Menu path

<b>Display</b>	Device setup ► Detailed setup ► Totalizer ► (see below)
<b>HART</b>	Device root menu ► Detailed setup ► Totalizer ► (see below)

Parameter		Description
Display	HART	
Totalizer 1 ► Count unit	Totalizer1 ► Total1 count unit	Specifies the desired unit of up to 8 characters to the totalizer 1 count.
Totalizer 2 ► Count unit	Totalizer2 ► Total2 count unit	Specifies the desired unit of up to 8 characters to the totalizer 2 count.
Totalizer 3 ► Count unit	Totalizer3 ► Total3 count unit	Specifies the desired unit of up to 8 characters to the totalizer 3 count.

**NOTE**

When the totalized value on the display exceeds ±99999999 which is the maximum value of the displayed digits, the behavior of the displayed value depends on the revision of Main soft rev (Main board revision / Main soft rev) and Ind soft rev (Indicator board revision / Ind soft rev).

Main soft rev	Ind soft rev	Totalizer Operation
R1.01.06 or earlier	R2.01.01 or earlier	Holds upper limit
R1.01.07	R2.01.02 ~ R2.01.03	Resets to 0
R2.02.01 or later	R2.02.01 or later	Selectable to hold upper limit or reset to 0

**■ Setting totalizer reset mode**

This function is available when Main soft rev (Main board revision/Main soft rev) is R2.02.01 or later and Ind soft rev (Indicator board revision/Ind soft rev) is R2.02.01 or later. This menu sets the behavior of the totalized value and the totalized count value when their upper limits are exceeded can be set.

**Menu path**

<b>Display</b>	Device setup ► Detailed setup ► Totalizer ► Reset mode
<b>HART</b>	Device root menu ► Detailed setup ► Totalizer ► Totalizer reset mode

From the table below, select the totalizer reset mode.

Selection		Description
Display	HART	
Off	Off	Holds at upper limit
On	On	Resets to 0

**4.2.3 Totalization Switch Function**

When a target value (threshold) to totalize is specified, it can be used as a totalization switch function. The totalization switch function can compare the specified target value with the totalized value and output the result in status output.

The status output is active while the totalized value exceeds the specified target value. Even if the totalized value exceeds the displayed digit limit and is reset to 0 under that state, the status output remains active.

For details about the output, active direction, and status output function setting for each terminal, refer to Section 4.3.

This setting can be configured with the following parameters.

**Menu path**

<b>Display</b>	Device setup ► Detailed setup ► Totalizer ► (see below)
<b>HART</b>	Device root menu ► Detailed setup ► Totalizer ► (see below)

Parameter		Description
Display	HART	
Totalizer 1 ► Set point	Totalizer1 ► Total1 set point	Specifies the target value of totalizer 1.
Totalizer 2 ► Set point	Totalizer2 ► Total2 set point	Specifies the target value of totalizer 2.
Totalizer 3 ► Set point	Totalizer3 ► Total3 set point	Specifies the target value of totalizer 3.

**Example: Setting procedure to use the totalization switch function with the pulse/status output 1.**

Follow the steps below to set the status output of pulse/status output 1 to “On active” when the totalized value of totalizer 1 reaches the target value.

- (1) Refer to Subsection 4.3.1 to specify the output of pulse/status output 1 to “Status output”.
- (2) Refer to Subsection 4.3.5 to specify the active direction of pulse/status output 1 to “On active”.
- (3) Refer to Subsection 4.3.9 to specify the status output function to “Total limit 1”.
- (4) Refer to this subsection to specify the target value of totalizer 1.

## 4.2.4 Totalizer Operation at Alarm Occurrence

The totalizer operation can be specified to deal with an alarm that affects the totalization function. This setting can be configured with the following parameters.

**Menu path**

<b>Display</b>	Device setup ► Detailed setup ► Totalizer ► (see below)
<b>HART</b>	Device root menu ► Detailed setup ► Totalizer ► (see below)

Parameter		Description
Display	HART	
Totalizer 1 ► Failure opts	Totalizer1 ► Total1 fail opts	Specifies totalizer 1 operation to be performed when an alarm occurs.
Totalizer 2 ► Failure opts	Totalizer2 ► Total2 fail opts	Specifies totalizer 2 operation to be performed when an alarm occurs.
Totalizer 3 ► Failure opts	Totalizer3 ► Total3 fail opts	Specifies totalizer 3 operation to be performed when an alarm occurs.

From the table below, select the operation of the totalization function.

Selection		Description
Display	HART	
Measured value	Measured value	Continues the totalization function during an alarm.
Stop	Stop	Stops the totalization function during an alarm.
Last valid	Last valid	Continues the totalization function with the last valid value right before the alarm occurred during an alarm.

## 4.2.5 Start/Stop Setting for Totalization Function

The start/stop operation of the totalization function can be set. This setting can be configured with the following parameters.

**Menu path**

<b>Display</b>	Device setup ► Detailed setup ► Totalizer ► (see below)
<b>HART</b>	Device root menu ► Detailed setup ► Totalizer ► (see below)

Parameter		Description
Display	HART	
Totalizer 1 ► Start/Stop	Totalizer1 ► Total1 Start/Stop	Specifies Start/Stop to the totalization function of totalizer 1.
Totalizer 2 ► Start/Stop	Totalizer2 ► Total2 Start/Stop	Specifies Start/Stop to the totalization function of totalizer 2.
Totalizer 3 ► Start/Stop	Totalizer3 ► Total3 Start/Stop	Specifies Start/Stop to the totalization function of totalizer 3.

**NOTE**

The totalization function is set to “Stop” at shipment from the manufacturing factory. To start the totalization function, be sure to set it to “Start”.

## 4.2.6 Totalization Direction Setting

The totalization direction can be specified when using the totalization function. This setting can be configured with the following parameters.

**Menu path**

<b>Display</b>	Device setup ► Detailed setup ► Totalizer ► (see below)
<b>HART</b>	Device root menu ► Detailed setup ► Totalizer ► (see below)

Parameter		Description
Display	HART	
Totalizer 1 ► Options	Totalizer1 ► Total1 options	Specifies the totalization direction of totalizer 1.
Totalizer 2 ► Options	Totalizer2 ► Total2 options	Specifies the totalization direction of totalizer 2.
Totalizer 3 ► Options	Totalizer3 ► Total3 options	Specifies the totalization direction of totalizer 3.

From the table below, select the totalization direction.

Selection		Description
Display	HART	
Balanced	Balanced	Totalizes the differential flow rate between the forward and reverse directions.
Absolute	Absolute	Totalizes the absolute value of the flow rate.
Only positive	Only positive	Totalizes only the flow rate in the forward direction.
Only negative	Only negative	Totalizes only the flow rate in the reverse direction.
Hold	Hold	Stops totalization processing (holds the current totalized value).

## 4.2.7 Totalized Value Reset/Preset Function

The reset/preset function can be specified for the totalized value. If the reset function is used, the function resets the totalized value to “0”. If the preset function is used, it sets the preset value specified in advance to the totalized value. The preset function is used when starting to count totalization from the specified value.

This setting can be configured with the following parameters.

### ■ Use of the reset/preset function

**Menu path**

<b>Display</b>	Device setup ► Detailed setup ► Totalizer ► (see below)
<b>HART</b>	Device root menu ► Detailed setup ► Totalizer ► (see below)

Parameter		Description
Display	HART	
Totalizer 1 ► Reset/Preset	Totalizer1 ► Total1 Reset/Preset	Uses the reset/preset function of totalizer 1.
Totalizer 2 ► Reset/Preset	Totalizer2 ► Total2 Reset/Preset	Uses the reset/preset function of totalizer 2.
Totalizer 3 ► Reset/Preset	Totalizer3 ► Total3 Reset/Preset	Uses the reset/preset function of totalizer 3.

From the table below, select the reset/preset function.

Selection		Description
Display	HART	
Not execute	Not execute	Does not use the reset/preset function of the totalized value.
Reset	Reset	Uses the reset function of the totalized value.
Preset	Preset	Uses the preset function for the totalized value.

### ■ Preset value setting

**Menu path**

<b>Display</b>	Device setup ► Detailed setup ► Totalizer ► (see below)
<b>HART</b>	Device root menu ► Detailed setup ► Totalizer ► (see below)

Parameter		Description
Display	HART	
Totalizer 1 ► Preset value	Totalizer1 ► Total1 preset value	Specifies the preset value of totalizer 1.
Totalizer 2 ► Preset value	Totalizer2 ► Total2 preset value	Specifies the preset value of totalizer 2.
Totalizer 3 ► Preset value	Totalizer3 ► Total3 preset value	Specifies the preset value of totalizer 3.

### NOTE

The parameter returns to “Not execute” after the reset/preset function of the totalized value has been completed.

## 4.3 Pulse Output, Frequency Output, and Status Output

### 4.3.1 Pulse/Status Output Mode Setting

Select the output mode of the pulse/status.  
This setting can be configured with the following parameters.

**Menu path**

<b>Display</b>	Device setup ► Detailed setup ► Pulse/Status out ► (see below)
<b>HART</b>	Device root menu ► Detailed setup ► Pulse/Status ► (see below)

Parameter		Description
Display	HART	
PO1/SO1 ► Output mode	Pulse/Status output1 ► Pulse1 output mode	Specifies the output mode of pulse/status output 1.
PO2/SO2 ► Output mode	Pulse/Status output2 ► Pulse2 output mode	Specifies the output mode of pulse/status output 2.

From the table below, select the output mode.

Selection		Description
Display	HART	
No function	No function	Does not use the terminal.
Fixed pulse output	Fixed pulse output	Specifies the output to the fixed width pulse output.
Frequency output	Frequency output	Specifies the output to the frequency output (Duty 50%).
Status output	Status output	Specifies the output to the status output. For details about the status output, refer to Subsection 4.3.9.



### 4.3.2 Pulse Output/Frequency Output Mapping

When using as a pulse output or frequency output, the process value to be output needs to be selected.

For pulse/status output 1, a process value does not need to be set because the PV-mapped process value in Subsection 4.1.2 is an output target.

For pulse/status output 2, the process value to be output can be selected among the flow velocity, volumetric flow rate, mass flow rate, calorie, and flow noise.

This setting can be configured with the following parameters.

**Menu path**

<b>Display</b>	Device setup ► Detailed setup ► Pulse/Status out ► PO2/SO2 ► Pulse select
<b>HART</b>	Device root menu ► Detailed setup ► Pulse/Status ► Pulse/Status output2 ► Pulse2 select

This parameter specifies a process value output from pulse/status output 2.

From the table below, select the process value to be output.

Selection		Description
Display	HART	
No connect	Non-Connect	No output.
Velocity	Velocity	Specifies the flow velocity to the output.
Volume flow	Volume flow	Specifies the volumetric flow rate to the output.
Mass flow	Mass flow	Specifies the mass flow rate to the output.
Calorie	Calorie	Specifies the calorie to the output. (Only available for AXG, not for AXW)
Diag	Diag	Specifies the flow noise to the output. (Only available for AXG, not for AXW)

### 4.3.3 Alarm Output Function

It is possible to specify the output behavior for when an alarm occurs while being used as a pulse output or frequency output.

This setting can be configured with the following parameters.

**Menu path**

<b>Display</b>	Device setup ► Detailed setup ► Pulse/Status out ► (see below)
<b>HART</b>	Device root menu ► Detailed setup ► Pulse/Status ► (see below)

Parameter		Description
Display	HART	
PO1/SO1 ► Alarm out	Pulse/Status output1 ► Pulse1 alarm out	Specifies the alarm output function of pulse output 1 and frequency output 1.
PO2/SO2 ► Alarm out	Pulse/Status output2 ► Pulse2 alarm out	Specifies the alarm output function of pulse output 2 and frequency output 2.

From the table below, select the output operation of the alarm output function.

Selection		Description
Display	HART	
0 pps	0 pps	No output.
Measured value	Measured value	Outputs the frequency or pulse with the measured value.
Last valid	Last valid	Outputs the frequency or pulse with the last valid value before an alarm activates.
Max pps	Max pps	Outputs the frequency or pulse at 12500 pps.

### 4.3.4 Pulse Width Setting

The pulse width can be selected for use as a fixed width pulse. This setting can be configured with the following parameters.

**Menu path**

<b>Display</b>	Device setup ▶ Detailed setup ▶ Pulse/Status out ▶ (see below)
<b>HART</b>	Device root menu ▶ Detailed setup ▶ Pulse/Status ▶ (see below)

Parameter		Description
Display	HART	
PO1/SO1 ▶ Fix width	Pulse/Status output1 ▶ Pulse1 fix width	Specifies the pulse width of pulse output 1.
PO2/SO2 ▶ Fix width	Pulse/Status output2 ▶ Pulse2 fix width	Specifies the pulse width of pulse output 2.

From the table below, select the pulse width.

Pulse width [ms]	Max. output frequency [Hz]
0.05	10000
0.1	5000
0.5	1000
1	500
20	25
33	15
50	10
100	5
200	2.5
330	1.5
500	1.0
1000	0.5
2000	0.25
Duty cycle 50%*	—

\*: Available for Main soft rev (Main board revision/Main soft rev) R2.02.01 or later and Ind soft rev (Indicator board revision/ Ind soft rev) R2.02.01 or later.

### NOTE

The maximum pulse width when “Duty cycle 50%” is selected is up to 300 seconds (5 minutes). To output pulse whose period exceeds 10 minutes, the pulse width is fixed to 300 seconds. There is not the above limitation on Main soft rev (Main board revision/Main soft rev) R2.02.30 or later. And the tracking performance for flow rate changes from low flow rates has been improved.

### 4.3.5 Active Direction Setting

When the pulse output or status output is used, either ON or OFF can be set to active for the pulse signal.

This setting can be configured with the following parameters.

**Menu path**

<b>Display</b>	Device setup ▶ Detailed setup ▶ Pulse/Status out ▶ (see below)
<b>HART</b>	Device root menu ▶ Detailed setup ▶ Pulse/Status ▶ (see below)

Parameter		Description
Display	HART	
PO1/SO1 ▶ Active mode	Pulse/Status output1 ▶ Pulse1 active mode	Specifies the active direction of the pulse signal of pulse/status output 1.
PO2/SO2 ▶ Active mode	Pulse/Status output2 ▶ Pulse2 active mode	Specifies the active direction of the pulse signal of pulse/status output 2.
SO3 ▶ Active mode	Status output 3 ▶ Status output3 active mode	Specifies the active direction of the pulse signal of status output 3.

From the table below, select the active direction of the pulse signal.

Selection		Description
Display	HART	
On active	On active	Sets to Active when the pulse signal is set on.
Off active	Off active	Sets to Active when the pulse signal is set off.

**Example:**

If the fixed pulse output is specified and the pulse width is set to “1 ms”, it is set to active as shown below.

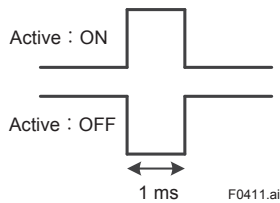

### 4.3.6 Active Pulse Setting

When communication and I/O code JG, L is selected, the sensor will be set and shipped so that the sensor operates with pulse output 2 specified as a mechanical counter. This setting can be changed by the customer.

The mechanical counter specifications have the following limitations.

<b>Maximum pulse rate</b>	2pps
<b>Pulse width</b>	20ms, 33ms, 50ms, 100ms
<b>Active direction</b>	On active

Refer to the Installation Manual on how to connect with the mechanical counter.

**Menu path**

<b>Display</b>	Device setup ► Detailed setup ► Pulse/Status out ► PO2/SO2 ► Active pulse
<b>HART</b>	Device root menu ► Detailed setup ► Pulse/Status ► Pulse/Status output2 ► Active pulse mode

Selection		Description
Display	HART	
Normal	Normal	Normal pulse
For magnetic counter	For magnetic counter	Mechanical counter specification pulse

### 4.3.7 Pulse Rate Setting

When the pulse output is used, the pulse rate value per pulse and pulse rate scaling can be specified.

The unit of the pulse rate is the same as the unit of the PV-mapped process value in Subsection 4.1.2.

This setting can be configured with the following parameters. If the pulse rate scaling is changed, the pulse rate value is also converted to match the changed unit.

#### ■ Pulse rate value

**Menu path**

<b>Display</b>	Device setup ► Detailed setup ► Pulse/Status out ► (see below)
<b>HART</b>	Device root menu ► Detailed setup ► Pulse/Status ► (see below)

Parameter		Description
Display	HART	
PO1/SO1 ► Rate value	Pulse/Status output1 ► Pulse1 rate value	Specifies the pulse rate of pulse output 1.
PO2/SO2 ► Rate value	Pulse/Status output2 ► Pulse2 rate value	Specifies the pulse rate of pulse output 2.

## ■ Scaling pulse rate

### Menu path

<b>Display</b>	Device setup ▶ Detailed setup ▶ Pulse/Status out ▶ ( see below)
<b>HART</b>	Device root menu ▶ Detailed setup ▶ Pulse/Status ▶ ( see below)

Parameter		Description
Display	HART	
PO1/SO1 ▶ Rate unit	Pulse/Status output1 ▶ Pulse1 rate unit	Specifies the scaling of the pulse rate of pulse output 1.
PO2/SO2 ▶ Rate unit	Pulse/Status output2 ▶ Pulse2 rate unit	Specifies the scaling of the pulse rate of pulse output 2.

From the table below, select the pulse rate scaling.

Selection	Description
n unit/P	$10^{-9}$ × units per pulse
u unit/P	$10^{-6}$ × units per pulse
m unit/P	$10^{-3}$ × units per pulse
Unit/P	1 unit per pulse
k unit/P	$10^3$ × units per pulse
M unit/P	$10^6$ × units per pulse
n P/unit	$10^{-9}$ × pulses per unit
u P/unit	$10^{-6}$ × pulses per unit
m P/unit	$10^{-3}$ × pulses per unit
P/unit	1 pulse per unit
k P/unit	$10^3$ × pulses per unit
M P/unit	$10^6$ × pulses per unit

Unit: The unit of the process value to be output as a pulse output

### NOTE

The maximum pulse rate and pulse width must be specified so that the following conditions are satisfied.

Maximum pulse rate value [pps]

$$= \text{Flow rate span [Unit/s]} \times \text{Pulse rate [P/Unit]}$$

$$\leq 10 \text{ [k pps]}$$

$$\leq 1 / (\text{Pulse width} \times 2)$$

### Example:

When the pulse width is set to “0.1 ms”, the maximum pulse rate value is set to “ $1 / (0.0001 \times 2) = 5000$  [pps]”. If the specified pulse rate exceeds this value, it causes a setting error, and an alarm is displayed.

### 4.3.8 Frequency Output Range Setting

When the frequency output is used, the frequency at 0% and 100% can be specified for the span of the process value. The frequency output range can be set by specifying the frequency. When the frequency output 1 is used, the output frequency is to be set for the span of the PV-mapped process value in Subsection 4.1.2. When the frequency output 2 is used, the output frequency is to be set for the span of the mapped process value in Subsection 4.3.2. This setting can be configured with the following parameters.

**Menu path**

<b>Display</b>	Device setup ► Detailed setup ► Pulse/Status out ► (see below)
<b>HART</b>	Device root menu ► Detailed setup ► Pulse/Status ► (see below)

Parameter		Description
Display	HART	
PO1/SO1 ► Frequency at 0%	Pulse/Status output1 ► Frequency1 at 0%	Specifies the frequency when the process value to be output with frequency output 1 is set to 0%.
PO1/SO1 ► Frequency at 100%	Pulse/Status output1 ► Frequency1 at 100%	Specifies the frequency when the process value to be output with frequency output 1 is set to 100%.
PO2/SO2 ► Frequency at 0%	Pulse/Status output2 ► Frequency2 at 0%	Specifies the frequency when the process value to be output with frequency output 2 is set to 0%.
PO2/SO2 ► Frequency at 100%	Pulse/Status output2 ► Frequency2 at 100%	Specifies the frequency when the process value to be output with frequency output 2 is set to 100%.

### 4.3.9 Status Output Function Setting

The product state can be output as a contact point to use the status output. This setting can be configured with the following parameters.

**Menu path**

<b>Display</b>	Device setup ► Detailed setup ► Pulse/Status out ► (see below)
<b>HART</b>	Device root menu ► Detailed setup ► Pulse/Status ► (see below)

Parameter		Description
Display	HART	
PO1/SO1 ► SO1 function	Pulse/Status output1 ► Status output1 function	Specifies status output 1 function.
PO2/SO2 ► SO2 function	Pulse/Status output2 ► Status output2 function	Specifies status output 2 function.
SO3 ► Function	Status output3 ► Status output3 function	Specifies status output 3 function.

From the table below, select the status output function.

Selection		Description
Display	HART	
No function	No function	The status output is not available because the status output function is not enabled.
Alarm output	Alarm output	The status output is activated when an alarm occurs.
Warning output	Warning output	The status output is activated when a warning occurs.
Total limit 1	Total limit1	The status output is activated when the totalized value of totalizer 1 exceeds the specified target value. For details about the totalization switch function, refer to Subsection 4.2.3.
Total limit 2	Total limit2	The status output is activated when the totalized value of totalizer 2 exceeds the specified target value. For details about the totalization switch function, refer to Subsection 4.2.3.
Total limit 3	Total limit3	The status output is activated when the totalized value of totalizer 3 exceeds the specified target value. For details about the totalization switch function, refer to Subsection 4.2.3.
H/L alarm	H/L alarm	The status output is activated when the PV-mapped process value is equal to or lower than the specified low limit (L) or equal to or greater than the specified high limit (H). For details about the PV mapping for the process value and alarm information, refer to Subsection 4.1.2, Section 4.8, and Subsection 4.11.2.
HH/LL alarm	HH/LL alarm	The status output is active while the PV-mapped process value is equal to or lower than the specified low-low limit (LL) or equal to or greater than high-high limit (HH). For details about the PV mapping for the process value and alarm information, refer to Subsection 4.1.2, Section 4.8, and Subsection 4.11.2.
Fwd/Rev range	Fwd/Rev range	Used for forward/reverse range. A flow rate can be measured by switching analog output 1 between the forward range and reverse range in response to a flow direction. The status output is activated when the present range is the reverse range. For details, refer to Subsection 4.6.4.

Selection		Description
Display	HART	
Auto 2 range	Auto2 range	Used for the multi range. A flow rate can be measured while switching analog output 1 between range 1 and range 2 in response to the flow rate. The status output is activated when the present range is range 2. For details, refer to Subsection 4.6.3.
Ext 2 answer	Ext2 answer	The status output is active when the present range is range 2 while operating with Ext 2 range settings. For details, refer to Subsection 4.6.7.
System alarm*	System alarm*	The status output is activated when System alarm occurs. Can be specified only with status output 2.
Process alarm*	Process alarm*	The status output is activated when Process alarm occurs. Can be specified only with status output 2.
Setting alarm*	Setting alarm*	The status output is activated when Setting alarm occurs. Can be specified only with status output 2.
Signal overflow*	50:Sig overflow*	The status output is activated when Signal overflow occurs. Can be specified only with status output 2.
Empty detect*	51:Empty detect*	The status output is activated when Empty pipe detection occurs. Can be specified only with status output 2.
Adh over lv 4*	53:Adh over lv4*	The status output is activated when Adhesion over level 4 occurs. Can be specified only with status output 2.
Cable miscon*	85:Cable miscon*	The status output is activated when Cable misconnect occurs. Can be specified only with status output 2.
Coil insulation*	86:Coil insulate*	The status output is activated when Coil insulation occurs. Can be specified only with status output 2.
Adhesion lv 3*	87:Adh over lv3*	The status output is activated when Adhesion lv 3 occurs. Can be specified only with status output 2.
LC warn*	88:LC warn*	The status output is activated when Low conductivity Warning occurs. Can be specified only with status output 2.
Insu detect*	89:Insu detect*	The status output is activated when Insulation detection occurs. Can be specified only with status output 2.
FLN over lv 3*	90:FLN over lv3*	The status output is activated when Flow noise over level 3 occurs. Can be specified only with status output 2.
FLN over lv 4*	91:FLN over lv4*	The status output is activated when Flow noise over level 4 occurs. Can be specified only with status output 2.
Verif warn*	93:Verif warn*	The status output is activated when Verification warning occurs. Can be specified only with status output 2.
Fact noise warn*	94:FC noise warn*	The status output is activated when Factory noise warning occurs. Can be specified only with status output 2.
Low alarm*	Lo alarm*	The status output is activated when the PV-mapped process value is equal to or less than the low limit (L) and exceeds the low-low limit value (LL). Can be specified only with status output 2.
LL alarm*	Lo Lo alarm*	The status output is activated when the PV-mapped process value is equal to or less than the specified low-low limit value (LL). Can be specified only with status output 2.
High alarm*	Hi alarm*	The status output is activated when the PV-mapped process value is equal to or greater than the specified high limit (H) and no more than the high-high limit (HH). Can be specified only with status output 2.



Selection		Description
Display	HART	
HH alarm*	Hi Hi alarm*	The status output is activated when the PV-mapped process value is equal to or greater than the specified high-high limit (HH). Can be specified only with status output 2.

\*: Available for Main soft rev (Main board revision/Main soft rev) R2.02.01 or later and Ind soft rev (Indicator board revision/ Ind soft rev) R2.02.01 or later.

### 4.3.10 Pulse Option Setting

This function is available when Main soft rev (Main board revision/Main soft rev) is R2.02.01 or later and Ind soft rev (Indicator board revision/Ind soft rev) is R2.02.01 or later.  
 An instantaneous flow rate is totalized for the fixed width pulse output or frequency output and is output as a pulse when the totalized value exceeds 1. With the pulse option, the totalization method can be selected.

<b>Display</b>	Device setup ▶ Detailed setup ▶ Pulse/Status out ▶ (see below)
<b>HART</b>	Device root menu ▶ Detailed setup ▶ Pulse/Status ▶ (see below)

Parameter		Description
Display	HART	
PO1/SO1 ▶ Options	Pulse/Status outpu1 ▶ Pulse1 option	Specifies pulse 1 option.
PO2/SO2 ▶ Options	Pulse/Status outpu2 ▶ Pulse2 option	Specifies pulse 2 option.

Selection		Description
Display	HART	
Balanced	Balanced	Totalizes a flow rate in the forward direction with a positive value and a flow rate in the reverse direction with a negative value, and outputs a value as a pulse if the forward and negative totalized values exceed 1.
Absolute	Absolute	Totalizes an absolute value of the flow rate and outputs it as a pulse if the totalized value exceeds 1.
Only positive	Only positive	Totalizes only a flow rate in the forward direction and outputs it as a pulse if the totalized value exceeds 1. (The negative flow rate is not totalized as 0)
Only negative	Only negative	Converts a negative flow rate to a positive value and totalizes it. Outputs the value as a pulse if the value exceeds 1. (The negative flow rate is not totalized in the forward direction as 0)

Use “Balanced” and “Absolute” in the following cases.

<b>Balanced</b>	When raising 0% point with frequency output Setting example) Pulse mode = Freq, Freq at 0% = 100Hz, Freq at 100% = 500Hz, Pulse option = Balanced Since 100Hz is output at 0% with the above settings, an instantaneous flow rate can be measured up to -25% in frequency output. (Possible to use in the same way as the analog output)
<b>Absolute</b>	When using in combination with forward/reverse range Setting example) Pulse mode = Fixed, Pulse option = Absolute, SO function = Fwd/Rev range Please set your desired value for pulse width / rate / rate unit, and reverse span1. With the above settings, the same pulse output can be reproduced as when the forward/reverse range setting is made with the old model AXF.

## 4.4 Status Input

### 4.4.1 Active Direction Setting for Status Input

When the status input is used, either ON or OFF can be set to active for the status input. This setting can be configured with the following parameters.

**Menu path**

<b>Display</b>	Device setup ▶ Detailed setup ▶ Status in ▶ SI3 ▶ Active mode
<b>HART</b>	Device root menu ▶ Detailed setup ▶ Pulse/Status ▶ Status input 3 ▶ Status input3 active mode

From the table below, select the active direction of the status input.

Selection		Description
Display	HART	
On active	Short(On) act	Specifies the status input to Active when it is shorted-circuited.
Off active	Open(Off) act	Specifies the status input to Active when it is open.

## 4.4.2 Status Input Function Setting

When the status input is used, the function of the status input can be set. This setting can be configured with the following parameters.

**Menu path**

<b>Display</b>	Device setup ► Detailed setup ► Status in ► SI3 ► Function
<b>HART</b>	Device root menu ► Detailed setup ► Pulse/Status ► Status input 3 ► Status input3 function

From the table below, select the status input function.

Selection		Description
Display	HART	
No function	No function	The status input is not available because the status input function is not enabled.
0% signal lock	0% Signal Lock	Analog output 1 is fixed at 4 mA when the status input becomes active.
Ext auto zero	Ext auto zero	The zero adjustment function is automatically used when the status input is active. Note that zero adjustment cannot be stopped even if the status input is changed while the zero adjustment function is used.
Total preset 1	Total preset 1	The preset value specified in Subsection 4.2.7 is set as the value for totalizer 1 and totalization starts from the value when the status input is active.
Total preset 2	Total preset 2	The preset value specified in Subsection 4.2.7 is set as the value for totalizer 2 and totalization starts from the value when the status input becomes active.
Total preset 3	Total preset 3	The preset value specified in Subsection 4.2.7 is set as the value for totalizer 3 and totalization starts from the value when the status input becomes active.
Ext 2 ranges	Ext2 ranges	The range of analog output 1 is switched from range 1 to range 2 while the status input is active. Used for External Contact Range. For details on the external contact range, refer to Subsection 4.6.6.
0% signal lock 2*	0% Signal Lock 2*	A flow rate is fixed at 0 when the status input becomes active. Due to this, the analog output, pulse output and flow rate on the display become 0.

\*: Available for Main soft rev (Main board revision/Main soft rev) R2.02.01 or later and Ind soft rev (Indicator board revision/ Ind soft rev) R2.02.01 or later.

## 4.5 Analog Input and Analog Output

### 4.5.1 Analog Output Select

This parameter is only available for AXG, not for AXW.

The process value to be assigned to analog output 2 is set.

In the case of analog output 1, the process value does not need to be set because the PV-mapped process value in Subsection 4.1.2 is an output target.

This setting can be configured with the following parameters.

**Menu path**

<b>Display</b>	Device setup ► Detailed setup ► Analog out/in ► AO2 ► AO2 select
<b>HART</b>	Device root menu ► Detailed setup ► Analog output/input ► Analog output 2 ► AO2 select

From the table below, select the process value for the analog output.

Selection		Description
Display	HART	
No connect	Non-Connect	No output.
Velocity	Velocity	Specifies the flow velocity to the output.
Volume flow	Volume flow	Specifies the volumetric flow rate to the output.
Mass flow	Mass flow	Specifies the mass flow rate to the output.
Calorie	Calorie	Specifies the calorie to the output.
Diag	Diag	Specifies the flow noise to the output.

### 4.5.2 Display Analog Output

The current value of the analog output can be checked with the following parameters.

**Menu path**

<b>Display</b>	Device setup ► Process variables ► (see below)
<b>HART</b>	Process variables root menu ► View outputs ► (see below)

Parameter		Description
Display	HART	
AO1	AO1 current	Displays the current value of analog output 1.
AO2	AO2 current	Displays the current value of analog output 2. (Only available for AXG, not for AXW)

### 4.5.3 Analog Output High/Low Limit Function

The high and low limits of the analog output can be set for each terminal. The high limit can be limited between 4.0 mA and 21.6 mA, and the low limit to between 2.4 mA and 20.0 mA.

This setting can be configured with the following parameters.

**Menu path**

<b>Display</b>	Device setup ► Detailed setup ► Analog out/in ► (see below)
<b>HART</b>	Device root menu ► Detailed setup ► Analog output/input ► (see below)

Parameter		Description
Display	HART	
AO1 ► High limit	Analog output1 ► AO1 high limit	Specifies the high limit of analog output 1.
AO1 ► Low limit	Analog output1 ► AO1 low limit	Specifies the low limit of analog output 1.
AO2 ► High limit	Analog output2 ► AO2 high limit	Specifies the high limit of analog output 2. (Only available for AXG, not for AXW)
AO2 ► Low limit	Analog output2 ► AO2 low limit	Specifies the low limit of analog output 2. (Only available for AXG, not for AXW)

**Example:**

If the high limit is set to 16 mA and the low limit to 8 mA, the result is as shown below.

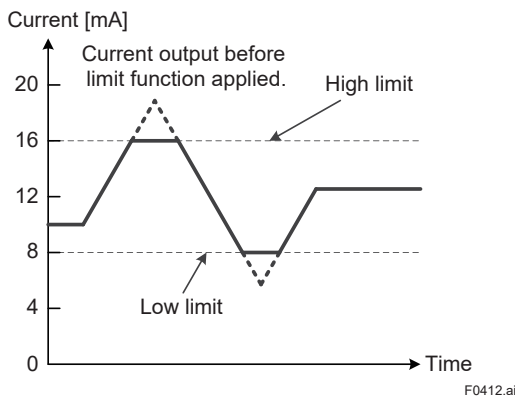

### 4.5.4 Absolute Range Function

The absolute range function is available for using analog output 1. If the absolute range function is used, the forward flow rate and reverse flow rate toward a span can be output to analog output at the same time. With 0% flow rate set at 12 mA, the reverse flow rate can be output to an analog output of 4 to 12 mA, and the forward flow rate to an analog output of 12 to 20 mA. The absolute range function and low-cut function can be used at the same time. For details about the low-cut function, refer to Subsection 4.1.7.

This setting can be configured with the following parameters.

**Menu path**

<b>Display</b>	Device setup ▶ Detailed setup ▶ Analog out/in ▶ AO1 ▶ Range mode
<b>HART</b>	Device root menu ▶ Detailed setup ▶ Analog output/input ▶ Analog output1 ▶ AO1 range mode

This parameter sets the use of the absolute range function for analog output 1.

From the table below, select the use of the absolute range function.

Selection		Description
Display	HART	
Normal range	Normal range	Does not use the absolute range function.
Abs range	Abs range	Uses the absolute range function.

**Example:**

(1) With absolute range and no low cut

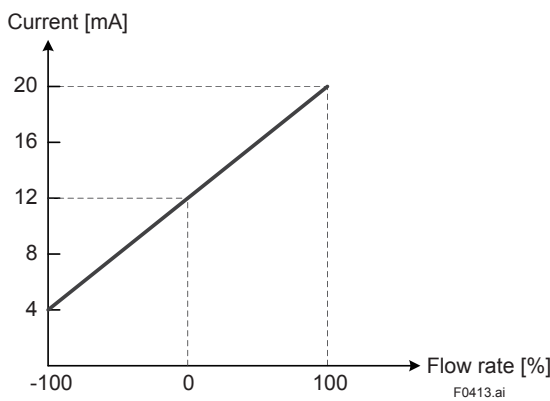

(2) With absolute range and low cut

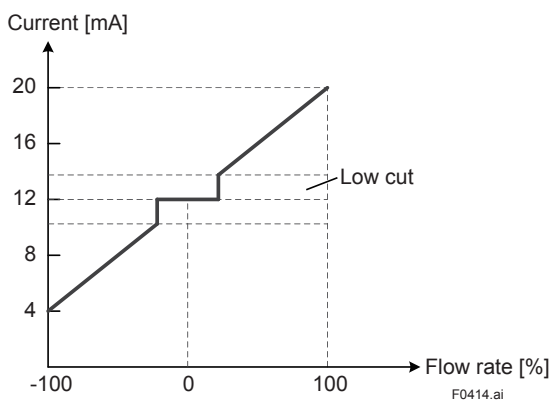

**NOTE**

The absolute range function and multi range function cannot be used at the same time.

### 4.5.5 Alarm Output Function

Behavior of the analog output when a target alarm occurs can be set with the alarm output function.

This setting can be configured with the following parameters.

**Menu path**

<b>Display</b>	Device setup ► Detailed setup ► Analog out/in ► (see below)
<b>HART</b>	Device root menu ► Detailed setup ► Analog output/input ► (see below)

Parameter		Description
Display	HART	
AO1 ► Alarm out	Analog output1 ► AO1 alarm out	Specifies the alarm output function of analog output 1.
AO2 ► Alarm out	Analog output2 ► AO2 alarm out	Specifies the alarm output function of analog output 2. (Only available for AXG, not for AXW)

From the table below, select the use of the alarm output function.

Selection		Description
Display	HART	
< 2.4 mA	< 2.4 mA	Outputs lower than 2.4 mA.
3.8 mA	3.8 mA	Outputs 3.8 mA.
4 mA	4 mA	Outputs 4 mA.
20.5 mA	20.5 mA	Outputs 20.5 mA.
> 21.6 mA	> 21.6 mA	Outputs higher than 21.6 mA.
Measured value	Measured value	Outputs measured current (the current value is undefined due to an error).
Hold	Hold	Outputs current that is applied when an alarm occurs.

### 4.5.6 Analog Output Priority

The function of the prioritized analog output varies depending on the settings of the product.

Priority level	Output mode
High  Low	HART multi-drop mode, fixed output of 4 mA (For details, refer to Subsection 3.6.3.)
	Test mode bit (For details, refer to Section 4.12.)
	Status input function Output of 0% signal lock (For details, refer to Subsection 4.4.2.)
	Alarm output function (For details, refer to Subsection 4.5.5.)
	Verification function, Output during offline diagnosis (For details, refer to Subsection 4.11.6.)
	Normal output



## 4.5.7 Current Value Adjustment

After the sensor is installed to the customer's piping, an analog input value or analog output value can be adjusted in the customer's installation environment. To adjust an analog output value, output currents of 4 mA and 20 mA from this product, connect an ammeter for calibration, and measure the current value.

Set the measured current value to the parameter and adjust the analog output value.

To adjust the analog input value, input currents of 4 mA and 20 mA from an external device, and display the analog input value on the display of this product. For details about settings of the display item, refer to Subsection 4.9.2.

Set the displayed analog value (adjusted value) to the parameter and adjust the analog input value.

This setting can be configured with the following parameters.

### ■ Analog input

This parameter is only available for AXG, not for AXW.

#### Menu path

<b>Display</b>	Device setup ► Diag/Service ► AO/AI trim ► AI trim ► (see below)
<b>HART</b>	Maintenance root menu ► AO/AI trim ► AI trim ► (see below)

Parameter		Description
Display	HART	
Trim 4mA	AI trim	Specifies the adjustment value when inputting 4 mA of analog input.
Trim 20mA		Specifies the adjustment value when inputting 20 mA of analog input.
Trim clear	Clear AI trim	Clears the adjustment value for inputting analog input.

### ■ Analog output

#### Menu path

<b>Display</b>	Device setup ► Diag/Service ► AO/AI trim ► AO trim ► (see below)
<b>HART</b>	Maintenance root menu ► AO/AI trim ► AO trim ► (see below)

Parameter		Description
Display	HART	
AO1 trim 4mA	AO1 trim	Specifies the adjustment value of analog output 1 (4 mA).
AO1 trim 20mA		Specifies the adjustment value of analog output 1 (20 mA).
AO1 trim clear	Clear D/A trim 1	Clears the adjustment value of analog output 1.
AO2 trim 4mA	AO2 trim	Specifies the adjustment value of analog output 2 (4 mA). (Only available for AXG, not for AXW)
AO2 trim 20mA		Specifies the adjustment value of analog output 2 (20 mA). (Only available for AXG, not for AXW)
AO2 trim clear	Clear D/A trim 2	Clears the adjustment value of analog output 2. (Only available for AXG, not for AXW)

## IMPORTANT

If the input/output does not agree with the readings of the current value when the current value adjustment function is used, readjust the current value.

### 4.5.8 Analog Input Function Setting

This parameter is only available for AXG, not for AXW.

A process value from an external device can be imported to the product as an analog input. The analog input can be used for temperature-based density correction calculation and calorie calculation by using the analog input as a temperature input.

For details about the temperature-input density correction calculation and calorie calculation, refer to Subsections 4.7.5 and 4.7.6.

This setting can be configured with the following parameters.

**Menu path**

<b>Display</b>	Device setup ► Detailed setup ► Analog out/in ► AI ► Function
<b>HART</b>	Device root menu ► Detailed setup ► Analog output/input ► Analog input ► AI function

This parameter specifies the analog input function.

From the table below, select the analog input function.

Selection		Description
Display	HART	
No function	No function	An analog input is not available because the analog input function is not enabled.
Monitoring	Monitoring	The analog input value can be monitored. However, this function does not give any influences on either the density correction calculation or the calorie calculation.
Diff temperature	Diff temperature	The analog input is used as the temperature difference. Calorie can be calculated.
Ext temperature	Ext temperature	The analog input is used as absolute temperature. Density correction and calorie can be calculated.

### 4.5.9 Display Analog Input

This parameter is only available for AXG, not for AXW.

The current value of the analog input can be checked with the following parameters.

**Menu path**

<b>Display</b>	Device setup ► Detailed setup ► Analog out/in ► AI ► Value
<b>HART</b>	Process variables root menu ► View inputs ► AI current

### 4.5.10 Analog Input Unit Setting

This parameter is only available for AXG, not for AXW.

A unit can be set for when an analog input is used as an input for temperature.

This setting can be configured with the following parameters.

**Menu path**

<b>Display</b>	Device setup ► Detailed setup ► Analog out/in ► AI ► Unit
<b>HART</b>	Device root menu ► Detailed setup ► Analog output/input ► Analog input ► AI unit

### 4.5.11 Analog Input Range Setting

These parameters are only available for AXG, not for AXW.

A range can be set for the process value for the analog input by specifying 0% and 100% of the process value for the analog input. The unit for the range is the same as the unit specified in Subsection 4.5.10.

This setting can be configured with the following parameters.

**Menu path**

<b>Display</b>	Device setup ► Detailed setup ► Analog out/in ► AI ► (see below)
<b>HART</b>	Device root menu ► Detailed setup ► Analog output/input ► Analog input ► (see below)

Parameter		Description
Display	HART	
URV	AI URV	Specifies the value that is at the 100% point of the process value for the analog input.
LRV	AI LRV	Specifies the value that is at the 0% point of the process value for the analog input.

### 4.5.12 Analog Input High/Low Limit Function

These parameters are only available for AXG, not for AXW.

High and low limits can be set for the analog input.

The high limit can be set to between 4.0 mA and 21.6 mA, and the low limit to between 2.4 mA and 20.0 mA.

This setting can be configured with the following parameters.

**Menu path**

<b>Display</b>	Device setup ► Detailed setup ► Analog out/in ► AI ► (see below)
<b>HART</b>	Device root menu ► Detailed setup ► Analog output/input ► Analog input ► (see below)

Parameter		Description
Display	HART	
High limit	AI high limit	Specifies the high limit value of the analog input value.
Low limit	AI low limit	Specifies the low limit value of the analog input value.

## 4.6 Multi Range Function

### 4.6.1 Multi Range type

The multi range function can be used for analog output 1. The multi range function shows the present range with the status input or status output. The multi range function makes it possible to measure a span for the PV-mapped process value in Subsection 4.1.2 while switching multiple ranges.

The multi range function has three ranges; the multi range, the forward/reverse range, and the external contact range, and one of the ranges should be selected.

The contents of each range are as follows:

<b>Multi range</b>	The state of the range is output in the status output by measuring a flow while switching several ranges in response to flow rate.
<b>Forward/Reverse range</b>	The state of the range is output in the status output by measuring a flow while switching several ranges in response to the flow direction.
<b>External Contact Range</b>	Flow is measured while switching several ranges by using the status inputs.

#### NOTE

- The absolute range function and multi range function cannot be used at the same time.
- The multi range function is not available for analog output 2.

### 4.6.2 Multi Range Setting

When using the multi range function, each range needs to be configured. For unit setting, refer to Subsection 4.1.4.

This setting can be configured with the following parameters. Refer to Subsection 4.1.5. for the span setting (forward span 1) when the multi range function is not used.

#### Menu path

<b>Display</b>	Device setup ► Detailed setup ► Multi range ► (see below)
<b>HART</b>	Device root menu ► Detailed setup ► Multi range ► (see below)

Parameter		Description
Display	HART	
Forward span 2	Forward span 2	Specifies forward span 2.
Reverse span 1	Reverse span 1	Specifies reverse span 1.
Reverse span 2	Reverse span 2	Specifies reverse span 2.

The type of the range for the multi range function can be set with the status output and status input functions. For details, refer to Subsections 4.3.9. and 4.4.2.

It is necessary to set a span for each range in response to the range type of the multi range function. Set each span value so as to satisfy the relation of lower range  $\leq$  upper range.

For example, if the forward/reverse range is to be used in combination with the multi range (range 1 and 2), spans of forward span 1, forward span 2, reverse span 1, and reverse span 2 need to be set, and the relations of forward span 1  $\leq$  forward span 2 and reverse span 1  $\leq$  reverse span 2 should be satisfied.

If these conditions are not met, "Analog output 1 multi range error" occurs and the multi range function does not operate.

### 4.6.3 Multi Range Operation

The multi range allows two ranges to be automatically switched for measurement in response to the flow rate. When a measured flow rate is larger than the lower range, the range is switched to the higher range. When a measured flow rate is smaller than the higher range, the range is switched to the lower range.

The range being used is shown with the state of the status output. When the multi range is used in range 1 and 2, the relation of the range and status output is as follows:

Range	State of status output (auto 2 range indicated)
Forward span 1	Not active
Forward span 2	Active

When the range is switched from the higher range to the lower range, it has hysteresis. The hysteresis sets a percentage for the lower range.

The hysteresis for multi range switching can be set with the following parameters.

**Menu path**

<b>Display</b>	Device setup ► Detailed setup ► Multi range ► Auto range hyst
<b>HART</b>	Device root menu ► Detailed setup ► Multi range ► Auto range hyst

When multi range is used in range1 and 2, the multi range can be set with the following procedures.

- (1) Refer to Subsection 4.1.2 to specify the PV process value.
- (2) Refer to Subsections 4.1.4 and 4.1.5 to specify the span (forward span 1).
- (3) Specify the multi range switching hysteresis.
- (4) Refer to Subsection 4.3.1 to specify the output of the terminal to the status output.
- (5) Refer to Subsection 4.3.9 to specify the status output function to auto 2 range.
- (6) Refer to Subsection 4.6.2 to specify forward span 2.

Specify a value greater than forward span 1.

**Example:**

PV = Volumetric flow rate,  
Flow rate span (range 1) = 50 m<sup>3</sup>/h,  
Range 2 = 100 m<sup>3</sup>/h,  
When set to Hysteresis width = 10 %  
->Hysteresis value = 50 [m<sup>3</sup>/h] × 10 [%]  
= 5 [m<sup>3</sup>/h]

(1) When the range is switched from lower range 1 to higher range 2

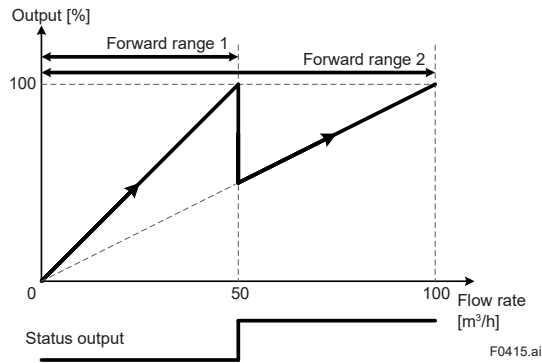

(2) When the range is switched from higher range 2 to lower range 1 (waiting for hysteresis)

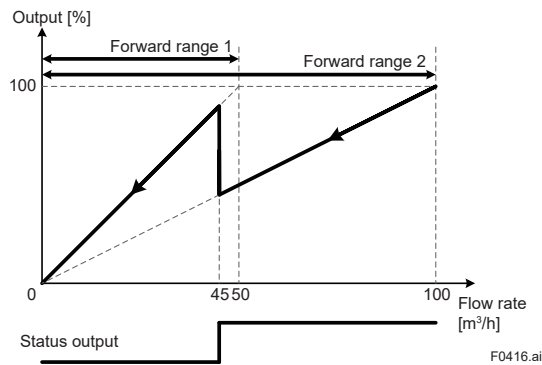

**NOTE**

To change the PV process value set in Subsection 4.1.2, it is necessary to re-set the multi range.

### 4.6.4 Forward/Reverse Range

In the forward/reverse range, this product measures a flow by automatically switching the forward direction range (forward range) and reverse direction range (reverse range) in response to the flow direction. Both the forward range and reverse range can be set for the range, respectively. The range being used is shown with the state of the status output. When the forward/reverse range is used, the relation of the range and status output is as follows:

Flow direction	Range	State of the status output (Forward/Reverse range)
Forward	Forward span 1	Not active
Reverse	Reverse span 1	Active

When the range is switched from the forward range to the reverse range, it has hysteresis. The hysteresis sets a percentage for either the forward range or the reverse range, whichever is smaller.

This setting can be configured with the following parameters.

**Menu path**

<b>Display</b>	Device setup ▶ Detailed setup ▶ Multi range ▶ Bi direction hyst
<b>HART</b>	Device root menu ▶ Detailed setup ▶ Multi range ▶ Bi direction hyst

The forward/reverse range can be configured with the following procedure.

- (1) Refer to Subsection 4.1.2 to specify the PV process value.
- (2) Refer to Subsections 4.1.4 and 4.1.5 to specify the span (forward span 1).
- (3) Specify the forward/reverse range switching hysteresis.
- (4) Refer to Subsection 4.3.1 to specify the output of the terminal to the status output.
- (5) Refer to Subsection 4.3.9 to specify the status output function to Fwd/Rev range.
- (6) Refer to Subsection 4.6.2 to specify reverse span 1.

### NOTE

If Main soft rev (Main board revision/Main soft rev) is R2.02.02 or later, when the Forward/Reverse function is switched between enabled and disabled by changing the Forward/Reverse range-related parameters, a value equivalent to 3% of the span is automatically set in the Total/Pulse low cut parameter.

To set an arbitrary low cut value, set the Total/Pulse low cut parameter after the above settings. If the Total/Pulse low cut parameter value is 0, the low cut parameter is not automatically set.

**Example:**

PV = Volumetric flow rate,  
Flow rate span (forward span 1) = 50 m<sup>3</sup>/h,  
Reverse span 1 = 100 m<sup>3</sup>/h,  
When set to Hysteresis = 5 %  
-> Because of Forward range < Reverse range  
Hysteresis value = 50 [m<sup>3</sup>/h] × 5 [%]  
= 2.5 [m<sup>3</sup>/h]

- (1) When the range is switched from the reverse range to the forward range (waiting for hysteresis)

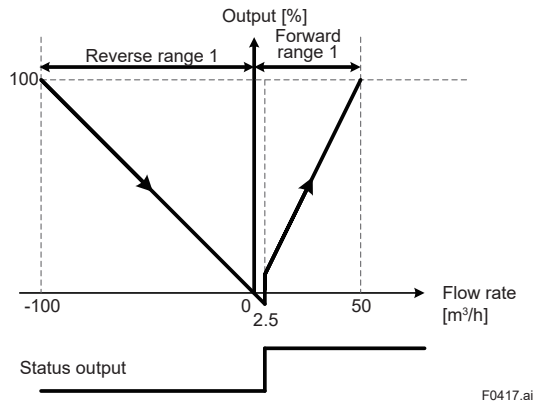

- (2) When the range is switched from the forward range to the reverse range (waiting for hysteresis)

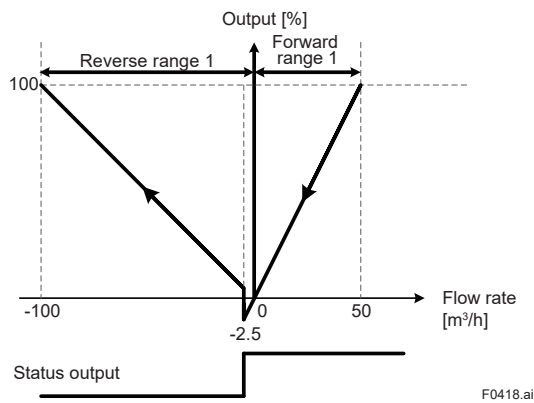

**NOTE**

To change the PV process value set in Subsection 4.1.2, it is necessary to re-set the forward/ reverse range.



## 4.6.5 Combination of Multi Range and Forward/Reverse Range

The multi range can be used in combination with the forward/reverse range for this product. When the multi range (range 1 to 2) and the forward/reverse range are combined, the relation of the range and status output is as follows:

Flow direction	Range	State of the status output (Forward/Reverse range)	State of the status output (Auto 2 range)
Forward	Forward span 2	Not active	Active
	Forward span 1	Not active	Not active
Reverse	Reverse span 1	Active	Not active
	Reverse span 2	Active	Active

The multi range and the forward/reverse range each have a different hysteresis. For the hystereses of the multi range and the forward/reverse range, refer to Subsections 4.6.3 and 4.6.4.

The combination of the forward/reverse range and the multi range (ranges 1 through 2) can be set using the following procedures.

- (1) Refer to Subsection 4.1.2 to specify the PV process value.
- (2) Refer to Subsections 4.1.4 and 4.1.5 to specify the span (forward span 1).
- (3) Refer to Subsections 4.6.3 and 4.6.4 to specify the hystereses for the multi range and the forward/reverse range.
- (4) Refer to Subsection 4.3.1 to specify the output of each terminal to the status output.
- (5) Refer to Subsection 4.3.9 to specify the status output function to auto 2 range and forward/reverse range.
- (6) Refer to Subsection 4.6.2 to specify forward span 2, reverse span 1, and reverse span 2.

### 4.6.6 External Contact Range

The external contact range can be used with this product. In the external contact range, a flow rate can be measured by arbitrarily switching two ranges in response to status input. The relation between a range and the status input is as follows:

State of status input (Ext 2 ranges)	Range
Not active	Range 1
Active	Range 2

When using the external contact range in ranges 1 and 2, it can be set with the following procedures.

- (1) Refer to Subsection 4.1.2 to specify the PV process value.
- (2) Refer to Subsections 4.1.4 and 4.1.5 to specify the span (forward span 1).
- (3) Refer to Subsection 4.4.2 to specify the function of the status input to Ext 2 ranges.
- (4) Refer to Subsection 4.6.2 to specify forward span 2.

**Example:**

PV = Volumetric flow rate,  
 Flow rate span (forward span 1) = 50 m<sup>3</sup>/h,  
 When setting the forward span 2 = 100 m<sup>3</sup>/h

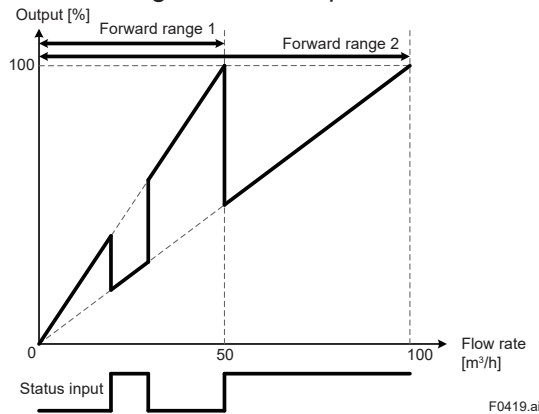

### 4.6.7 External Contact Range (with Answer)

This product can display the present range in the form of the state of status output while operating in the external contact range.

The relation between a range and the status output is as follows:

State of status input (Ext 2 ranges)	Range	State of the status output (Ext 2 answer)
Not active	Range 1	Not active
Active	Range 2	Active

The external contact range with answer can be configured using the following procedure.

- (1) Refer to Subsection 4.1.2 to specify the PV process value.
- (2) Refer to Subsections 4.1.4 and 4.1.5 to specify the span (forward span 1).
- (3) Refer to Subsection 4.4.2 to specify the function of the status input to Ext 2 ranges.
- (4) Refer to Subsection 4.3.9 to specify the function of the status output to Ext 2 answer.
- (5) Refer to Subsection 4.6.2 to specify forward span 2.

Example:

PV = Volumetric flow rate,

Flow rate span (forward span 1) = 50 m<sup>3</sup>/h,

When setting to forward span 2 = 100 m<sup>3</sup>/h

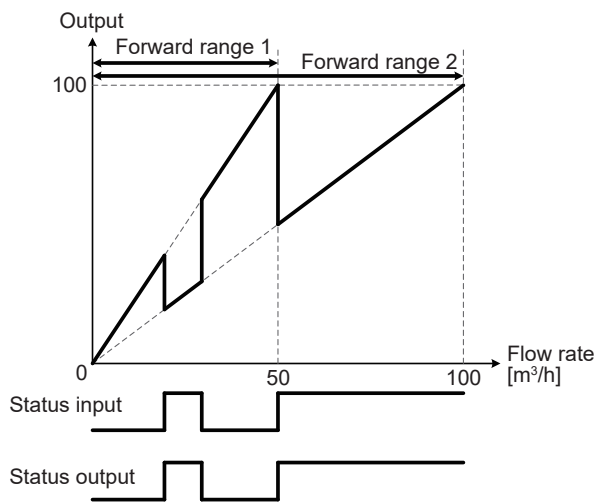

F0446.ai

### 4.6.8 Combination of External Contact Range and Forward/Reverse Range

The external contact range can be used in combination with the forward/reverse range for this product. The relation of the range and status output is as follows when the forward/reverse range and External Contact Range (range 1 and 2) are combined.

Condition		Operation		
Flow direction	State of status input (Ext 2 ranges)	Range	State of the status output (Forward/Reverse range)	State of the status output (Ext 2 answer)
Forward	Active	Forward span 2	Not active	Active
	Not active	Forward span 1	Not active	Not active
Reverse	Not active	Reverse span 1	Active	Not active
	Active	Reverse span 2	Active	Active

The combination of the forward/reverse range and the external contact range (range 1 and 2) can be set in the following procedures.

- (1) Refer to Subsection 4.1.2 to specify the PV process value.
- (2) Refer to Subsections 4.1.4 and 4.1.5 to specify span (forward span 1).
- (3) Refer to Subsections 4.6.3 and 4.6.4 to specify the hystereses for the multi range and the forward/reverse range.
- (4) Refer to Subsection 4.3.9 to specify the function of the status output to the forward/reverse range.
- (5) Refer to Subsection 4.4.2 to specify the function of the status input to Ext 2 ranges.
- (6) Refer to Subsection 4.6.2 to specify forward span 2, reverse span 1, and reverse span 2.

## 4.7 Auxiliary Calculation Function

### 4.7.1 Fluid Flow Direction Setting

The arrow on the surface of the sensor indicates the fluid flow direction. Upon shipment from the manufacturing factory, the flow rate is measured assuming that the arrow direction is forward. By changing the parameter settings, this product can measure the flow rate, assuming that the reverse direction is forward against the arrow direction.

This setting can be configured with the following parameters.

**Menu path**

<b>Display</b>	Device setup ► Detailed setup ► AUX calculation ► Flow direct
<b>HART</b>	Device root menu ► Detailed setup ► AUX calculation ► Flow direction

This parameter specifies the fluid flow direction. From the table below, select the fluid flow direction.

Selection		Description
Display	HART	
Forward	Forward	The arrow direction of the sensor is forward.
Reverse	Reverse	The reverse direction of the arrow of the sensor is forward.

### 4.7.2 Rate Limit Function Setting

If the rate limit function is used, it becomes possible to reduce noises that cannot all be cleared only by lengthening the damping time constant. When a step signal or a sudden signal due to a slurry fluid is input, this function judges whether the signal is a flow rate signal or a noise signal. This judgment is made based on the high/low limit value (rate limit value) and the rate limit function continuation time (dead time), causing the noise signal over the rate limit value to be cut off.

The rate limit value is specified with the percentage (%) for the span of the PV-mapped process value in Subsection 4.1.2. The dead time is set to "0" if the rate limit function is not used.

This setting can be configured with the following parameters.

**Menu path**

<b>Display</b>	Device setup ► Detailed setup ► AUX calculation ► (see below)
<b>HART</b>	Device root menu ► Detailed setup ► AUX calculation ► (see below)

Parameter		Description
Display	HART	
Rate limit	Rate limit	Specifies the rate limit value.
Dead time	Dead time	Specifies the dead time.
Noise filter	Noise filter	Specifies the noise filter (rate limit value and dead time).*1

\*1: From the table below, select the noise filter (rate limit value and dead time).

Selection		Rate limit value	Dead time
Display	HART		
Manual	Manual	The value is specified in the parameter "Rate limit".	The value is specified in the parameter "Dead time".
Level 1	Level 1	0.5%	0.5s
Level 2	Level 2	1.0%	1.0s
Level 3	Level 3	5.0%	3.0s

**NOTE**

If either the rate limit value or the dead time is specified, the noise filter is set to "Manual".

**NOTE**

**Determining the rate limit value and dead time**

**The Rate limit value:**

Determine the level which should be cut the output fluctuation. For example, if its level is 2%, the noise of 2% or larger would be cut as shown in the following figure.

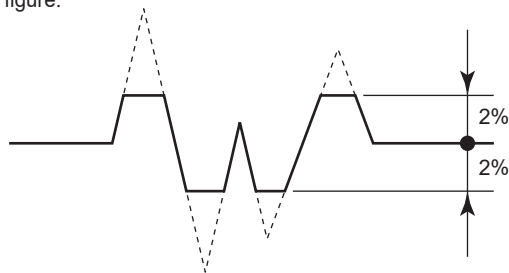

**The Dead time (T<sub>0</sub>):**

Determine the value depending on the width of the output fluctuation. Choose the larger value when the noise which is over the dead time as shown in the following figure.

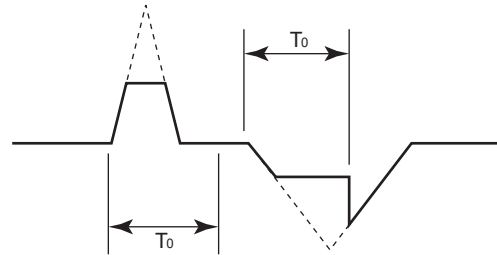

F0420.ai

**NOTE**

For the rate limit function, the dead time is set to "0" upon shipment from the manufacturing factory.

Be sure to set the dead time when the rate limit function is used.

**Signal processing for rate limit function**

The product calculates to set the specific rate limit value to the primary delay response value of the previously sampled flow rate value. If the flow rate value sampled at this time exceeds the rate limit value above, its high or low limit is set to the flow rate value at this time. Furthermore, if the sampling count occurs within the dead time while the signal over the high/low limit is in the same direction, this signal is judged to be a flow rate signal.

**Example:**

**(1) When input = 0 to 10%, Damping time constant = 5 seconds, Dead time = 3 seconds, and Rate limit value = 1%, the output for the step input is obtained as shown below.**

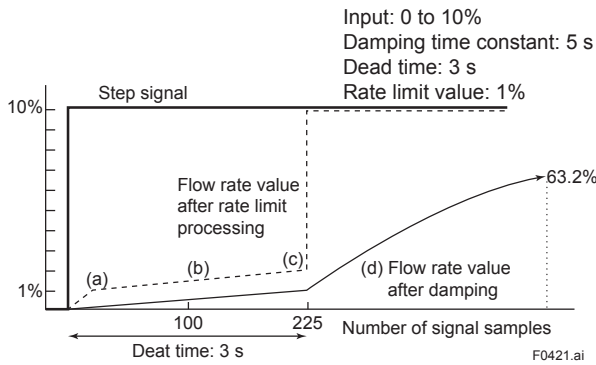

- In condition (a), the signal exceeds the rate limit value as compared with the previous value; therefore, the response is set to 1%.
- The actual output, which is damped, is processed as indicated by the solid line.
- Then, the flow rate value in the dead time is set to “flow rate after damping calculation + signal of rate limit value (1%)”.
- The input signal does not return to the rate limit value or less within the dead time; therefore, it is judged to be a flow rate signal at the time of (c).
- The output signal starts following the step signal along the damping curve.

The figure below shows an output example when a slurry noise has occurred.

**(2) When input = 0 to 10%, Damping time constant = 1 second, Dead time = 1 seconds, and Rate limit value = 1%, the output for a slurry noise is obtained as shown below.**

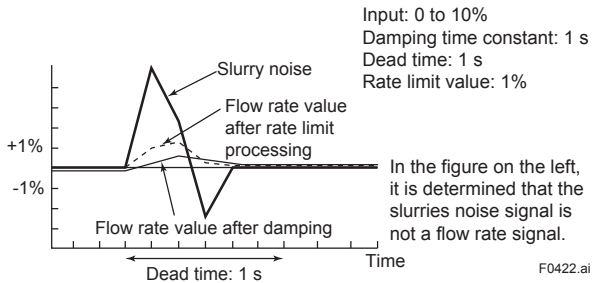

### 4.7.3 Pulsing Flow Support Function Setting

If a plunger pump is used, it may cause an error in the average of the flow rate due to the influence of the pulsing flow. If the pulsing flow support function is used, an error due to a pulsing flow can be reduced by following a flow change while controlling the flow rate calculation. This setting can be configured with the following parameters.

**Menu path**

<b>Display</b>	Device setup ► Detailed setup ► AUX calculation ► Pulsing flow
<b>HART</b>	Device root menu ► Detailed setup ► AUX calculation ► Pulsing flow

This parameter specifies the use of the pulsing flow support function. From the table below, select the use of the pulsing flow support function.

Selection		Description
Display	HART	
No	No	Do not use the pulsing flow support function.
Yes	Yes	Use the pulsing flow support function.

### 4.7.4 Power Frequency Synchronization Setting

This function can be specified whether the excitation frequency (internal signal processing frequency) and power frequency are synchronous or asynchronous. When setting the excitation frequency and power frequency to asynchronous, the excitation frequency is determined by the set value of the power frequency. The power frequency synchronous/asynchronous mode and the power frequency can be configured with the following parameters.

**Menu path**

<b>Display</b>	Device setup ► Detailed setup ► AUX calculation ► (see below)
<b>HART</b>	Device root menu ► Detailed setup ► AUX calculation ► (see below)

Parameter		Description
Display	HART	
Power sync	Power synchronize	Sets the excitation frequency and power frequency to synchronous.*1
Set power freq	Set power frequency	Sets the power frequency when the excitation frequency and power frequency are asynchronous.

\*1: Sets the synchronous/asynchronous mode of power frequency from the table below.

Selection		Description
Display	HART	
No	No	Sets the excitation frequency and power frequency asynchronous.
Yes	Yes	Sets the excitation frequency and power frequency synchronous.

## IMPORTANT

When using the DC power as the transmitter power, set the commercially available power frequency of the place where the transmitter will be used. In this case, set "Power sync" to Off first before setting "Set power freq".



The excitation frequency and power frequency can be checked with the following parameters.

**Menu path**

<b>Display</b>	Device setup ► Detailed setup ► AUX calculation ► (see below)
<b>HART</b>	Device root menu ► Detailed setup ► AUX calculation ► (see below)

Parameter		Description
Display	HART	
IEX power frequency	IEX power frequency	Displays the power frequency (synchronous with the excitation frequency).
Meas power freq	Measured power frequency	Displays the measured power frequency.

### 4.7.5 Density Correction Calculation

When the temperature from another device (temperature transmitter, etc.) is used as an analog input, the density correction calculation can be performed based on temperature. The measurement accuracy for the mass flow rate is improved by using this function.

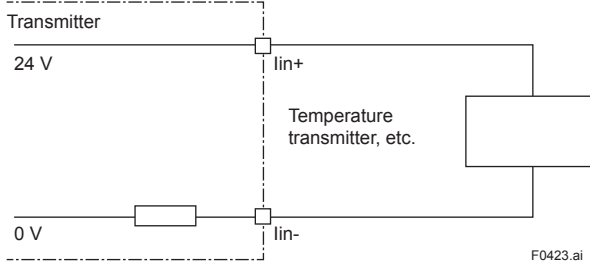

The mass flow rate is obtained using the following formula.

$$V_m = V_f \times \rho$$

$V_m$ : Mass flow rate [kg/s]  
 $V_f$ : Volumetric flow rate [m<sup>3</sup>/s]  
 $\rho$ : Density [kg/m<sup>3</sup>]

When the density correction calculation is performed based on temperature, the density is obtained using the following formula. The density compensating rates must be specified depending on applications that use this product.

$$\rho_r = \rho_n \times \{1 + a_1 \times (T_r - T_n) \times 10^{-2} + a_2 \times (T_r - T_n)^2 \times 10^{-6}\}$$

$\rho_r$ : Density corrected based on the measured temperature [kg/m<sup>3</sup>]  
 $\rho_n$ : Standard density [kg/m<sup>3</sup>]  
 $T_r$ : Measured temperature [°C]  
 $T_n$ : Standard temperature [°C]  
 $a_1$ : Primary compensating rate  
 $a_2$ : Secondary compensating rate

The standard temperature and the compensating rates can be configured with the following parameters.

**Menu path**

<b>Display</b>	Device setup ► Detailed setup ► Pro var ► Temperature ► (see below)
<b>HART</b>	Device root menu ► Detailed setup ► Process variables ► Temperature ► (see below)

Parameter		Description
Display	HART	
Coef A1	Temp coef A1	Specifies the primary compensating rate.
Coef A2	Temp coef A2	Specifies the secondary compensating rate.

The density correction calculation can be set using the following procedure.

- (1) Refer to Subsection 4.11.1 to specify the use of the temperature corrected density.
- (2) Refer to Subsection 4.5.8 to specify the function of the analog input to temperature.
- (3) Refer to Subsection 4.5.11 to specify the range of the analog input.
- (4) Refer to Subsections 4.1.11 and 4.1.12 to specify the standard temperature and standard density.
- (5) Specify the primary compensating rate and secondary compensating rate of the compensation formula.

## NOTE

The density correction calculation is performed only when items (1) and (2) above are specified. If they are not specified, the density is assigned to the fixed value that is specified in Subsection 4.1.11.

### Example:

If a water density is corrected based on the temperature in the following conditions, the result is obtained as shown below.

analog input range = 0.0 to 100.0°C,

Standard density = 1000 kg/m<sup>3</sup>,

Standard temperature = 20°C,

Primary compensating rate = -0.02, Secondary compensating rate = -3.9

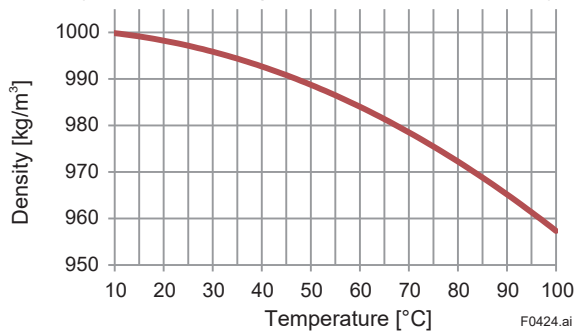

## 4.7.6 Calorie Calculation

This function is only available for AXG, not for AXW.

When the absolute temperature or the temperature difference from another device (temperature transmitter, etc.) is used as the analog input, the calorie calculation is executable.

The calorie is obtained using the following formula.

$$Q = c \times V_m \times \Delta t$$

Q: Calorie [J/s]

c: Specific heat [J/kg•K]

$V_m$ : Mass flow rate [kg/s]

$\Delta t$ : Temperature difference [K]

The temperature difference of  $\Delta t$  varies depending on the analog input function specified in Subsection 4.5.8. If “Diff temperature” is selected in the analog input function, the temperature input in the form of analog input is used. If “Ext temperature” is selected, the difference between the temperature used as the analog input and the reference temperature specified in Subsection 4.1.12 is used.

This setting can be configured with the following parameters.

### Menu path

<b>Display</b>	Device setup ► Detailed setup ► Pro var ► Calorie ► Specific heat
<b>HART</b>	Device root menu ► Basic setup ► Calorie ► Specific heat

This parameter specifies the specific heat.

The calorie calculation can be configured using the following procedure.

• **When the absolute temperature is selected as the analog input:**

- (1) Refer to Subsection 4.5.8 to specify the function of the analog input to “Ext temperature”.
- (2) Refer to Subsection 4.5.11 to specify the range of the analog input.
- (3) Refer to Subsection 4.1.12 to specify the reference temperature.
- (4) Specify the specific heat.

• **When the temperature difference is selected as the analog input:**

- (1) Refer to Subsection 4.5.8 to specify the function of the analog input to “Diff temperature”.
- (2) Refer to Subsection 4.5.11 to specify the range of the analog input.
- (3) Specify the specific heat.

### 4.7.7 Limit of Alarm Output Function

The alarm output function of analog output 1 can be limited. For details about the alarm output function, refer to Subsection 4.5.5.

This setting can be configured with the following parameters.

**Menu path**

<b>Display</b>	Device setup ► Detailed setup ► AUX calculation ► Set SIL
<b>HART</b>	Device root menu ► Detailed setup ► AUX calculation ► Set SIL

From the table below, select the use of the alarm output function.

Selection		Description
Display	HART	
No	No	Does not restrict the alarm output function of analog output 1.
Yes	Yes	Limits the alarm output function of analog output 1.

### NOTE

If this function is set to “Yes”, the alarm output function for analog output 1 is to be limited to “< 2.4 mA” and “> 21.6 mA”. If another option is set, the alarm output function for analog output 1 is set to “> 21.6 mA”.

## 4.8 Alarm

### 4.8.1 Errors and Countermeasures

Explanation of NE107 status:

NE107 status		Status of the device
F	Failure	Device malfunction, Parts malfunction
C	Function Check	The output signal is temporarily invalid for the local operation or manual operation input.
S	Out of specification	The device works in out of specification. The output signal is uncertain for the process or the ambiance.
M	Maintenance required	The maintenance is required in the near future.
N	No Effect	State other than mentioned above

The following table shows possible countermeasures.

#### ■ System alarm

The device breaks down and causes abnormal measurement.

Device replacement is needed.

NE107 Status	Error Message		Error Description	Countermeasure
	Display	HART		
F	010:Main CPU FAIL	10 Main board CPU failure	CPU (Main board) failure was detected.	Contact Yokogawa service center.
F	011:Rev calc FAIL	11 Reverse calculation failure	Failure of reverse calculation was detected.	Contact Yokogawa service center.
F	012:Main EEP FAIL	12 Main board EEPROM failure	Failure of EEPROM (Main board) was detected.	Turn on the power again within the range of the temperature specifications. If the situation does not improve, contact Yokogawa service center.
F	013:Main EEP dflt	13 Main board EEPROM default	EEPROM (Main board) was reset to default values.	Contact Yokogawa service center.
F	014:Snsr bd FAIL	14 Sensor board failure	Failure of sensor board was detected.	Contact Yokogawa service center.
F	015:Snsr comm ERR	15 Sensor communication error	Communication error of the sensor was detected.	Contact Yokogawa service center.
F	016:AD 1 FAIL[Sig]	16 A/D1 failure[Signal]	Failure of A/D transmitter 1 [flow velocity signal] was detected.	Contact Yokogawa service center.
F	017:AD 2 FAIL[Excit]	17 A/D2 failure[Exciter]	Failure of A/D transmitter 2 [Exciting current] was detected.	Contact Yokogawa service center.
F	018:Coil open	18 Coil open	Coil of sensor was disconnected.	Turn off the power, check coil of sensor and excitation cable.
F	019:Coil short	19 Coil short	Coil of sensor was shorted.	Contact Yokogawa service center.
F	020:Exciter FAIL	20 Exciter failure	Failure of the excitation circuit was detected.	Contact Yokogawa service center.
F	021:PWM 1 stop	21 PWM1 stop	Error of pulse width modulation 1 was detected.	Contact Yokogawa service center.

NE107 Status	Error Message		Error Description	Countermeasure	
	Display	HART			
F	022:PWM 2 stop	22	PWM2 stop	Error of pulse width modulation 2 was detected.	Contact Yokogawa service center.
F	023:Opt bd mismatch	23	Option board mismatch	Mismatch of option board was detected.	Contact Yokogawa service center.
F	024:Opt bd EEP FAIL	24	Option board EEPROM failure	Failure of EEPROM (option board) was detected.	Contact Yokogawa service center.
F	025:Opt bd A/D FAIL	25	Option board A/D failure	Failure of A/D (option board) was detected.	Contact Yokogawa service center.
F	026:Opt bd SPI FAIL	26	Option board SPI failure	Failure of SPI (option board) was detected.	Contact Yokogawa service center.
F	027:Restore FAIL	27	Parameter restore incomplete	Restore of parameters was failed.	Retry the restore function of the parameter.
F	028:Ind bd FAIL	28	Indicator board failure	Failure of display board was detected.	Check that the ambient temperature of display is within the range. If the situation does not improve, contact Yokogawa service center.
F	029:Ind bd EEP FAIL	29	Indicator board EEPROM failure	Failure of EEPROM (display board) was detected.	Turn on the power again within the range of the temperature specifications. If the situation does not improve, contact Yokogawa service center.
F	030:LCD drv FAIL	30	LCD driver failure	Failure of display driver was detected.	Contact Yokogawa service center.
F	031:Ind bd mismatch	31	Indicator board mismatch	Mismatch of display board was detected.	Contact Yokogawa service center.
F	032:Ind comm ERR	32	Indicator communication error	Communication error of display board was detected.	Check that the main and display boards are connected.
F	033:microSD FAIL	33	microSD card Failure	Failure of microSD card was detected.	Replace the microSD card.

## ■ Process alarm

The device works normally, but some issue of the process causes abnormal measurement. Maintenance work is needed.

NE107 Status	Error Message		Error Description	Countermeasure	
	Display	HART			
S	050:Signal overflow	50	Signal overflow	Failure of input signal was detected.	Check the signal and grounding cables are connected.
S	051:Empty detect	51	Empty pipe detection	Inside of sensor was detected to be empty. (Empty check)	Fill the sensor with water.
N	052:H/L HH/LL alm	52	H/L or HH/LL alarm	A flow rate exceeds the high/low limits or high-high/low-low limits.	Check the parameter setting related to flow rate and alarm high/low limit function.
S	053:Adh over lv 4	53	Adhesion over level 4	The resistance value of the electrodes exceeded Level 4. (Adhesion detection of insulation to the electrode)	Recommend cleaning electrode.

## ■ Setting alarm

The device works normally, but the parameter setting error occurs. Parameter setting is needed.

NE107 Status	Error Message		Error Description	Countermeasure	
	Display	HART			
S	060:Span cfg ERR	60	Span configuration error	Setting error of flow span was detected. (fulfill "0.05 m/s < span flow rate < 16 m/s")	Check the parameter setting related to span.
S	061:PV F cfg ERR	61	PV flow select configuration error	Flow noise was set to PV when flow noise could not be used.	Check or change the PV FLOW SEL parameter setting.
S	062:AO 1 4-20 lmt	62	Analog output 1 4-20mA limit error	Setting error of analog output 1 was detected. (fulfill "LRV < HRV")	Check the parameter setting related to analog output 1.
S	063:AO 2 4-20 lmt	63	Analog output 2 4-20mA limit error	Setting error of analog output 2 was detected. (fulfill "LRV < HRV")	Check the parameter setting related to analog output 2.
S	064:AO 1 mlt rng	64	Analog output 1 multi range error	Setting error of the multi range function was detected. (Span value settings of each range do not satisfy the relationship of lower range ≤ higher range, multi range settings for the status input and status output are erroneous, or the multi range and the absolute range are selected at the same time)	Check the parameter setting related to the multi range.
N	065:H/L cfg ERR	65	H/L HH/LL configuration error	Setting error of the alarm high/low limit function was detected. (fulfill "HRV - LRV > Hysteresis" and "HHRV - LLRV > Hysteresis")	Check the parameter setting related to the alarm high/low limit function.

NE107 Status	Error Message		Error Description	Countermeasure	
	Display	HART			
S	066:Density cfg ERR	66	Density configuration error	Setting error of density value was detected when PV was set to mass flow rate.	Check the parameter setting related to density.
S	067:Pls 1 cfg ERR	67	Pulse output 1 configuration error	Setting error of pulse output 1 was detected.	Check the parameter setting related to pulse output 1.
S	068:Pls 2 cfg ERR	68	Pulse output 2 configuration error	Setting error of pulse output 2 was detected.	Check the parameter setting related to pulse output 2.
C	069:Nomi size cfg	69	Nominal size configuration error	Configuration error of nominal size was detected. (fulfill "0.99 mm < nominal size of sensor < 3000.10 mm (0.01 inch < nominal size of sensor < 120.10 inch)")	Check the parameter setting related to nominal size.
C	070:Adh cfg ERR	70	Adhesion configuration error	Setting error of electrode adhesion detection function was detected. (fulfill "Level1 < Level2 < Level3 < Level4")	Check the parameter setting related to adhesion detection.
C	071:FLN cfg ERR	71	Flow noise configuration error	Setting error of flow noise verification function was detected. (fulfill "Level1 < Level2 < Level3 < Level4")	Change the parameter settings related to flow noise.
C	072:Log not start	72	Data logging not started	Data logging failed to start.	Insert the microSD card.



## Warning

The device works normally and measurement is also normal but warning occurs.

NE107 Status	Error Message		Error Description	Countermeasure	
	Display	HART			
S	080:AO 1 saturate	80	Analog output 1 saturated	Saturation of Analog output 1 was detected.	Check the parameter settings related to the process value and analog output 1.
S	081:AO 2 saturate	81	Analog output 2 saturated	Saturation of Analog output 2 was detected.	Check the parameter settings related to the process value and analog output 2.
S	082:Pls 1 saturate	82	Pulse output 1 saturated	Saturation of pulse output 1 was detected.	Check the parameter setting related to process value and pulse output 1.
S	083:Pls 2 saturate	83	Pulse output 2 saturated	Saturation of pulse output 2 was detected.	Check the parameter setting related to process value and pulse output 2.
S	084:AI saturate	84	Analog input saturated	Saturation of Analog input was detected.	Check analog input value and analog input parameter setting.
C	085:Cable miscon	85	Cable misconnect	Misconnection of cable was detected.	Check the signal cable and excitation cable connection.
C	086:Coil insulation	86	Coil insulation warning	Insulation deterioration of the coil was detected.	Contact Yokogawa service center.
M	087:Adhesion lv 3	87	Adhesion over level 3	The resistance value of the electrodes exceeded Level 3. (Adhesion detection of insulation to the electrode)	Recommend cleaning electrode.
N	088:LC warn	88	Low conductivity warning	Decrease of conductivity was detected.	Check fluid conductivity.
M	089:Insu detect	89	Insulation detection	Insulation deterioration of electrode was detected.	Contact Yokogawa service center.
N	090:FLN over lv 3	90	Flow noise over level 3	Flow noise exceeded Level 3. (Detection of flow noise)	Check if there is a problem with the fluid (conductivity, bubble, etc.).
N	091:FLN over lv 4	91	Flow noise over level 4	Flow noise exceeded Level 4. (Detection of flow noise)	Check if there is a problem with the fluid (conductivity, bubble, etc.).
C	092:AZ warn	92	Autozero warning	Result of zero adjustment exceeded 10 cm/s.	Check fluid is stopped when executing zero adjustment.
C	093:Verif warn	93	Verification warning	Interruption of verification function was detected.	Execute Verification again.
C	094:Fact noise warn	94	Factory noise warning	The fluctuation of flow became larger.	Check if there is a problem with the fluid.
C	095:Simulate active	95	Simulation active	A test mode for the flow velocity, volumetric flow rate, mass flow rate, calorie, analog output, pulse output, status input, or status output was executed.	Release simulation or test mode.

NE107 Status	Error Message		Error Description	Countermeasure	
	Display	HART			
S	096:AO 1 fix	96	Analog output 1 fixed	It was detected that analog output 1 is fixed.	Check whether analog output 1 is in the test mode or not.
S	097:AO 2 fix	97	Analog output 2 fixed	It was detected that analog output 2 is fixed.	Check whether analog output 2 is in the test mode or not.
S	098:PIs 1 fix	98	Pulse output 1 fixed	It was detected that pulse output 1 is fixed.	Check whether pulse output 1 is in the test mode or not.
S	099:PIs 2 fix	99	Pulse output 2 fixed	It was detected that pulse output 2 is fixed.	Check whether pulse output 2 is in the test mode or not.
S	100:AI fix	100	Analog input fixed	It was detected that the analog input is fixed.	Check whether the analog input is in the test mode or not.
C	101:Param restore run	101	Parameter restore running	The restore function of the parameter was executed.	—
N	102:Disp over	102	Display over warning	The number of digits available for display exceeded the limit.	Check the parameter setting related to display.
N	103:SD size warn	103	microSD card size warning	Free space of microSD card decreased to less than 10%.	Increase the free space of the microSD card.
M	104:Bkup incmplt	104	Parameter backup incomplete	Parameter backup failed.	Retry the backup function of the parameter.
S	105:SD mismatch	105	microSD card mismatch	Mismatch of microSD card was detected.	Replace the microSD card.
M	106:SD removal ERR	106	microSD card removal procedure error	Removal of microSD card failed.	After executing the removal of the microSD card with parameter, remove the microSD card from the product.
N	131:Trans mismatch	131	Transmitter type mismatch	Mismatch of the sensor and transmitter was detected.	Contact Yokogawa service center.

## Information

The device works normally and measurement is also normal. These messages are just reference information.

NE107 Status	Error Message		Error Description	Countermeasure	
	Display	HART			
N	120:Watchdog	120	Watchdog	Error of Watchdog timer was detected.	Contact Yokogawa service center.
N	121:Power off	121	Power off	Power-off was detected.	—
N	122:Inst power FAIL	122	Instant power failure	Instantaneous power failure was detected.	—
N	123:Param bkup run	123	Parameter backup running	Parameter backup is running.	—
N	124:Data log run	124	Data logging running	Data log is running.	—
N	130:DevID not enter	130	Device ID not entered	No settings of Device ID was detected.	Contact Yokogawa service center.

## 4.8.2 Operation at the Time of Error

The following table shows the behavior of outputs and readings at the time of error.

### ■ System alarm

NE 107	Error Message	Output				Totalizer	Process Value	Display
		Alarm	Warning	Current	Pulse/Status			
F	010:Main CPU FAIL	Active	Non-Active	Burnout	Stop	Stop	Stop	Not defined
F	011:Rev calc FAIL	Active	Non-Active	Alarm Out	Alarm Out	Based on "FailOpts"	Normal Operation	Alarm
F	012:Main EEP FAIL	Active	Non-Active	Alarm Out	Alarm Out	Based on "FailOpts"	Normal Operation	Alarm
F	013:Main EEP dflt	Active	Non-Active	Alarm Out	Alarm Out	Based on "FailOpts"	Normal Operation	Alarm
F	014:Snsr bd FAIL	Active	Non-Active	Alarm Out	Alarm Out	Based on "FailOpts"	Hold Prior setting	Alarm
F	015:Snsr comm ERR	Active	Non-Active	Burnout	Alarm Out	Based on "FailOpts"	Hold Prior setting	Alarm
F	016:AD 1 FAIL[Sig]	Active	Non-Active	Alarm Out	Alarm Out	Based on "FailOpts"	Hold Prior setting	Alarm
F	017:AD 2 FAIL[Excit]	Active	Non-Active	Alarm Out	Alarm Out	Based on "FailOpts"	Hold Prior setting	Alarm
F	018:Coil open	Active	Non-Active	Alarm Out	Alarm Out	Based on "FailOpts"	Hold Prior setting	Alarm
F	019:Coil short	Active	Non-Active	Alarm Out	Alarm Out	Based on "FailOpts"	Hold Prior setting	Alarm
F	020:Exciter FAIL	Active	Non-Active	Alarm Out	Alarm Out	Based on "FailOpts"	Normal Operation	Alarm
F	021:PWM 1 stop	Active	Non-Active	Alarm Out	Alarm Out	Based on "FailOpts"	Normal Operation	Alarm
F	022:PWM 2 stop	Active	Non-Active	Alarm Out	Alarm Out	Based on "FailOpts"	Normal Operation	Alarm
F	023:Opt bd mismatch	Active	Non-Active	Alarm Out	Alarm Out	Based on "FailOpts"	Normal Operation	Alarm
F	024:Opt bd EEP FAIL	Active	Non-Active	Alarm Out	Alarm Out	Based on "FailOpts"	Normal Operation	Alarm
F	025:Opt bd A/D FAIL	Active	Non-Active	Alarm Out	Alarm Out	Based on "FailOpts"	Normal Operation	Alarm
F	026:Opt bd SPI FAIL	Active	Non-Active	Alarm Out	Alarm Out	Based on "FailOpts"	Normal Operation	Alarm
F	027:Restore FAIL	Active	Non-Active	Alarm Out	Alarm Out	Based on "FailOpts"	Normal Operation	Alarm
F	028:Ind bd FAIL	Active	Non-Active	Alarm Out	Alarm Out	Based on "FailOpts"	Normal Operation	Alarm
F	029:Ind bd EEP FAIL	Active	Non-Active	Alarm Out	Alarm Out	Based on "FailOpts"	Normal Operation	Alarm
F	030:LCD drv FAIL	Active	Non-Active	Alarm Out	Alarm Out	Based on "FailOpts"	Normal Operation	Alarm
F	031:Ind bd mismatch	Active	Non-Active	Alarm Out	Alarm Out	Based on "FailOpts"	Normal Operation	Alarm
F	032:Ind comm ERR	Active	Non-Active	Alarm Out	Alarm Out	Based on "FailOpts"	Normal Operation	Alarm
F	033:microSD FAIL	Active	Non-Active	Alarm Out	Alarm Out	Based on "FailOpts"	Normal Operation	Alarm

■ Process alarm

NE 107	Error Message	Output				Totalizer	Process Value	Display
		Alarm	Warning	Current	Pulse/Status			
S	050:Signal overflow	Active	Non-Active	Alarm Out	Alarm Out	Based on "FailOpts"	Hold Prior setting	Alarm
S	051:Empty detect	Active	Non-Active	Alarm Out	Alarm Out	Based on "FailOpts"	Hold Prior setting	Alarm
N	052:H/L HH/LL alm	Active	Non-Active	Normal	Normal	Continue	Normal Operation	Alarm
S	053:Adh over lv 4	Active	Non-Active	Alarm Out	Alarm Out	Based on "FailOpts"	Normal Operation	Alarm

■ Setting alarm

NE 107	Error Message	Output				Totalizer	Process Value	Display
		Alarm	Warning	Current	Pulse/Status			
S	060:Span cfg ERR	Active	Non-Active	Alarm Out	Alarm Out	Based on "FailOpts"	Normal Operation	Alarm
S	061:PV F cfg ERR	Active	Non-Active	Alarm Out	Alarm Out	Based on "FailOpts"	Normal Operation	Alarm
S	062:AO 1 4-20 lmt	Active	Non-Active	Normal	Normal	Continue	Normal Operation	Alarm
S	063:AO 2 4-20 lmt	Active	Non-Active	Normal	Normal	Continue	Normal Operation	Alarm
N	065:H/L cfg ERR	Active	Non-Active	Alarm Out	Normal	Based on "FailOpts"	Normal Operation	Alarm
S	066:Density cfg ERR	Active	Non-Active	Alarm Out	Alarm Out	Based on "FailOpts"	Normal Operation	Alarm
S	067:Pls 1 cfg ERR	Active	Non-Active	Alarm Out	Alarm Out	Continue	Normal Operation	Alarm
S	068:Pls 2 cfg ERR	Active	Non-Active	Alarm Out	Alarm Out	Continue	Normal Operation	Alarm
C	069:Nomi size cfg	Active	Non-Active	Alarm Out	Alarm Out	Based on "FailOpts"	Normal Operation	Alarm
C	070:Adh cfg ERR	Active	Non-Active	Normal	Normal	Continue	Normal Operation	Alarm
C	071:FLN cfg ERR	Active	Non-Active	Normal	Normal	Continue	Normal Operation	Alarm
C	072:Log not start	Active	Non-Active	Normal	Normal	Continue	Normal Operation	Alarm

■ Warning

NE 107	Error Message	Output				Totalizer	Process Value	Display
		Alarm	Warning	Current	Pulse/Status			
S	080:AO 1 saturate	Non-Active	Active	Normal	Normal	Continue	Normal Operation	Warning
S	081:AO 2 saturate	Non-Active	Active	Normal	Normal	Continue	Normal Operation	Warning
S	082:Pls 1 saturate	Non-Active	Active	Normal	Normal	Continue	Normal Operation	Warning
S	083:Pls 2 saturate	Non-Active	Active	Normal	Normal	Continue	Normal Operation	Warning
S	084:AI saturate	Non-Active	Active	Normal	Normal	Continue	Normal Operation	Warning
C	085:Cable miscon	Non-Active	Active	Normal	Normal	Continue	Normal Operation	Warning
C	086:Coil insulation	Non-Active	Active	Normal	Normal	Continue	Normal Operation	Warning
M	087:Adhesion lv 3	Non-Active	Active	Normal	Normal	Continue	Normal Operation	Warning
N	088:LC warn	Non-Active	Active	Normal	Normal	Continue	Normal Operation	Warning
M	089:Insu detect	Non-Active	Active	Normal	Normal	Continue	Normal Operation	Warning
N	090:FLN over lv 3	Non-Active	Active	Normal	Normal	Continue	Normal Operation	Warning
N	091:FLN over lv 4	Non-Active	Active	Normal	Normal	Continue	Normal Operation	Warning
C	092:AZ warn	Non-Active	Active	Normal	Normal	Continue	Normal Operation	Warning
C	093:Verif warn	Non-Active	Active	Normal	Normal	Continue	Normal Operation	Warning
C	094:Fact noise warn	Non-Active	Active	Normal	Normal	Continue	Normal Operation	Warning
C	095:Simulate active	Non-Active	Active	Normal	Normal	Continue	Normal Operation	Warning
S	096:AO 1 fix	Non-Active	Active	Normal	Normal	Continue	Normal Operation	Warning
S	097:AO 2 fix	Non-Active	Active	Normal	Normal	Continue	Normal Operation	Warning
S	098:Pls 1 fix	Non-Active	Active	Normal	Normal	Continue	Normal Operation	Warning
S	099:Pls 2 fix	Non-Active	Active	Normal	Normal	Continue	Normal Operation	Warning
S	100:AI fix	Non-Active	Active	Normal	Normal	Continue	Normal Operation	Warning
C	101:Param restore run	Non-Active	Active	Normal	Normal	Continue	Normal Operation	Execute
N	102:Disp over	Non-Active	Active	Normal	Normal	Continue	Normal Operation	Warning
N	103:SD size warn	Non-Active	Active	Normal	Normal	Continue	Normal Operation	Warning
M	104:Bkup incmplt	Non-Active	Active	Normal	Normal	Continue	Normal Operation	Warning
S	105:SD mismatch	Non-Active	Active	Normal	Normal	Continue	Normal Operation	Warning
M	106:SD removal ERR	Non-Active	Active	Normal	Normal	Continue	Normal Operation	Warning
N	131:Trans mismatch	Non-Active	Active	Normal	Normal	Continue	Normal Operation	Normal

■ Information

NE 107	Error Message	Output				Totalizer	Process Value	Display
		Alarm	Warning	Current	Pulse/ Status			
N	120:Watchdog	Non-Active	Active	Normal	Normal	Continue	Normal Operation	Normal
N	121:Power off	Non-Active	Active	Normal	Normal	Continue	Normal Operation	Normal
N	122:Inst power FAIL	Non-Active	Active	Normal	Normal	Continue	Normal Operation	Normal
N	123:Param bkup run	Non-Active	Active	Normal	Normal	Continue	Normal Operation	Execute
N	124:Data log run	Non-Active	Active	Normal	Normal	Continue	Normal Operation	Icon
N	130:DevID not enter	Non-Active	Active	Normal	Normal	Continue	Normal Operation	Normal

### 4.8.3 Alarm Display Setting

#### (1) Alarm display

If an error occurs on this product, an alarm appears on the display. The alarm display modes are classified into two types: one mode to display a process value and alarm name, and another mode to display an alarm name and action.

If multiple alarms occur on this product, they will be displayed in sequence on the display. This setting can be configured with the following parameters.

**Menu path**

<b>Display</b>	Device setup ► Detailed setup ► Display set ► Optional config ► Alarm display
<b>HART</b>	Device root menu ► Detailed setup ► Display ► Display operation configuration ► Display alarm

This parameter sets the alarm display.

From the table below, select the alarm display.

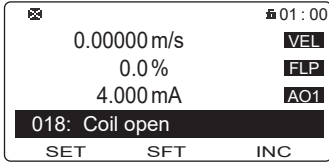
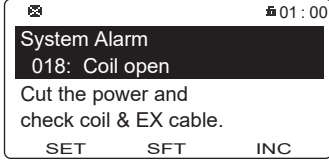
Selection		Description
Display	HART	
Normal	Normal	Displays the process value and alarm name.  <small>F0425.ai</small>
Detail	Detail	Displays the alarm name and action.  <small>F0426.ai</small>

#### (2) Alarm display based on NAMUR NE107

A prefix can be assigned to the alarm name based on NAMUR NE107.

This setting can be configured with the following parameters.

**Menu path**

<b>Display</b>	Device setup ► Detailed setup ► Display set ► Optional config ► NE107 display
<b>HART</b>	Device root menu ► Detailed setup ► Display ► Display operation configuration ► Display NE107

This parameter sets the alarm display based on NAMUR NE107.

From the table below, select the alarm display.

Selection		Description
Display	HART	
Normal	Normal	Sets to the normal alarm display.
NE107	NE107	Sets the alarm display based on NAMUR NE107.

## 4.8.4 Alarm History Function

The alarm history function can record an alarm that occurred in the past in the history. This setting can be configured with the following parameters.

**Menu path**

<b>Display</b>	Device setup ► Diag/Service ► Sts/Self test ► Alarm ► Alarm record ► (see below)
<b>HART</b>	Diagnostic root menu ► Status/Self test ► Alarm ► Alarm record ► (see below)

Parameter		Description
Display	HART	
Record alarm 1	Alarm record 1	Displays the name of new alarm 1.
Record time 1	Alarm record time 1	Displays the operation time when the first new alarm occurs.
Record alarm 2	Alarm record 2	Displays the name of new alarm 2.
Record time 2	Alarm record time 2	Displays the operation time when the second new alarm occurs.
Record alarm 3	Alarm record 3	Displays the name of new alarm 3.
Record time 3	Alarm record time 3	Displays the operation time when the third new alarm occurs.
Record alarm 4	Alarm record 4	Displays the name of new alarm 4.
Record time 4	Alarm record time 4	Displays the operation time when the fourth new alarm occurs.

The operation time when an alarm occurred is displayed in the format of “ddddD hh:mm”. “ddddD” indicates the day, “hh” indicates the hour, and “mm” indicates the minute.

**Example:**

“00031D 12:34” is displayed.

This example shows that an alarm has occurred when the product has been operated for 31 days, 12 hours, and 34 minutes.



## 4.8.5 Alarm Mask Function

The alarm mask function can be configured so that a set alarm is masked, alarm notifications are hidden, and the alarm history is not recorded. The mask function can be set for both the alarm notification and alarm record, respectively. This setting can be configured with the following parameters.

### ■ Alarm notification mask

If the alarm notification mask function is turned “On”, it disables alarm notification.

Setting example for alarm “Signal overflow”:

To disable the alarm notification, set “Signal overflow on” of Alarm out mask to “On”.

To enable the alarm notification, set “Signal overflow on” of Alarm out mask to “Off”.

#### Menu path

<b>Display</b>	Device setup ▶ Diag/Service ▶ Sts/Self test ▶ Alarm ▶ Alarm out mask ▶ (see below)
<b>HART</b>	Diagnostic root menu ▶ Status/Self test ▶ Alarm ▶ Alarm out mask ▶ (see below)

Parameter		Description
Display	HART	
Mask 1-1	Alarm out mask 1	Specifies the mask function for alarm notification 1-1.
Mask 1-2		Specifies the mask function for alarm notification 1-2.
Mask 2-1	Alarm out mask 2	Specifies the mask function for alarm notification 2-1.
Mask 2-2		Specifies the mask function for alarm notification 2-2.
Mask 3-1	Alarm out mask 3	Specifies the mask function for alarm notification 3-1.
Mask 3-2		Specifies the mask function for alarm notification 3-2.
Mask 4-1	Alarm out mask 4	Specifies the mask function for alarm notification 4-1.

### ■ Alarm record mask

If the alarm record mask function is turned “On”, it disables the alarm record.

Setting example for alarm “Empty pipe detection”:

To disable the alarm record, set “Empty pipe detection on” of Alarm out mask to “On”.

To enable the alarm record, set “Empty pipe detection on” of Alarm record mask to “Off”.

#### Menu path

<b>Display</b>	Device setup ▶ Diag/Service ▶ Sts/Self test ▶ Alarm ▶ Alarm record mask ▶ (see below)
<b>HART</b>	Diagnostic root menu ▶ Status/Self test ▶ Alarm ▶ Alarm record mask ▶ (see below)

Parameter		Description
Display	HART	
Mask 1-1	Alarm record mask 1	Specifies the mask function for alarm record 1-1.
Mask 1-2		Specifies the mask function for alarm record 1-2.
Mask 2-1	Alarm record mask 2	Specifies the mask function for alarm record 2-1.
Mask 2-2		Specifies the mask function for alarm record 2-2.
Mask 3-1	Alarm record mask 3	Specifies the mask function for alarm record 3-1.

**NOTE**

Note that an alarm masked by the alarm notification mask function is not recorded in the alarm record.

The alarm mask function setting is as follows:

<b>Parameter name</b>	Indicates the name of the mask setting parameter.
<b>Alarm name</b>	Indicates the alarm name.
<b>Default value</b>	Indicates the default value (upon shipment from the manufacturing factory). (✓: Masked, -: Not masked)
<b>Attribute</b>	Indicates whether the mask setting is enabled or disabled. (✓: Setting enabled, -: Setting disabled)

**Alarm notification mask function**

Display		HART			Default value	Attribute
Parameter name	Alarm name	Parameter name	Alarm name			
—	010:Main CPU FAIL	—	10	Main board CPU failure	—	—
—	011:Rev calc FAIL	—	11	Reverse calculation failure	—	—
—	012:Main EEP FAIL	—	12	Main board EEPROM failure	—	—
Mask 1-1	013:Main EEP dflt	Alarm out mask 1	13	Main board EEPROM default	—	✓
—	014:Snsr bd FAIL	—	14	Sensor board failure	—	—
—	015:Snsr comm ERR	—	15	Sensor communication error	—	—
—	016:AD 1 FAIL[Sig]	—	16	A/D1 failure[Signal]	—	—
—	017:AD 2 FAIL[Excit]	—	17	A/D2 failure[Exciter]	—	—
—	018:Coil open	—	18	Coil open	—	—
—	019:Coil short	—	19	Coil short	—	—
—	020:Exciter FAIL	—	20	Exciter failure	—	—
Mask 1-2	021:PWM 1 stop	Alarm out mask 1	21	PWM1 stop	—	✓
Mask 1-2	022:PWM 2 stop	Alarm out mask 1	22	PWM2 stop	—	✓
Mask 1-2	023:Opt bd mismatch	Alarm out mask 1	23	Option board mismatch	—	✓
Mask 1-2	024:Opt bd EEP FAIL	Alarm out mask 1	24	Option board EEPROM failure	—	✓
Mask 1-2	025:Opt bd A/D FAIL	Alarm out mask 1	25	Option board A/D failure	—	✓
Mask 1-2	026:Opt bd SPI FAIL	Alarm out mask 1	26	Option board SPI failure	—	✓
—	027:Restore FAIL	—	27	Parameter restore incomplete	—	—
Mask 1-2	028:Ind bd FAIL	Alarm out mask 1	28	Indicator board failure	✓	✓
Mask 1-2	029:Ind bd EEP FAIL	Alarm out mask 1	29	Indicator board EEPROM failure	—	✓
Mask 1-2	030:LCD drv FAIL	Alarm out mask 1	30	LCD driver failure	—	✓
Mask 1-2	031:Ind bd mismatch	Alarm out mask 1	31	Indicator board mismatch	—	✓
Mask 1-2	032:Ind comm ERR	Alarm out mask 1	32	Indicator communication error	—	✓
Mask 1-2	033:microSD FAIL	Alarm out mask 1	33	microSD failure	—	✓
Mask 2-1	050:Signal overflow	Alarm out mask 2	50	Signal overflow	—	✓
Mask 2-1	051:Empty detect	Alarm out mask 2	51	Empty pipe detection	—	✓

Display		HART			Default value	Attribute
Parameter name	Alarm name	Parameter name	Alarm name	Alarm name		
Mask 2-1	052:H/L HH/LL alm	Alarm out mask 2	52	H/L or HH/LL alarm	✓	✓
Mask 2-1	053:Adh over lv 4	Alarm out mask 2	53	Adhesion over level 4	✓	✓
Mask 2-1	060:Span cfg ERR	Alarm out mask 2	60	Span configuration error	—	✓
Mask 2-1	061:PV F cfg ERR	Alarm out mask 2	61	PV flow select configuration error	—	✓
Mask 2-1	062:AO 1 4-20 lmt	Alarm out mask 2	62	Analog output 1 4-20mA limit error	—	✓
Mask 2-1	063:AO 2 4-20 lmt	Alarm out mask 2	63	Analog output 2 4-20 mA limit error	—	✓
Mask 2-1	064:AO 1 mlt rng	Alarm out mask 2	64	Analog output 1 multi range error	—	✓
Mask 2-1	065:H/L cfg ERR	Alarm out mask 2	65	H/L HH/LL configuration error	—	✓
Mask 2-1	066:Density cfg ERR	Alarm out mask 2	66	Density configuration error	—	✓
Mask 2-2	067:Pls 1 cfg ERR	Alarm out mask 2	67	Pulse output 1 configuration error	—	✓
Mask 2-2	068:Pls 2 cfg ERR	Alarm out mask 2	68	Pulse output 2 configuration error	—	✓
Mask 2-2	069:Nomi size cfg	Alarm out mask 2	69	Nominal size configuration error	—	✓
Mask 2-2	070:Adh cfg ERR	Alarm out mask 2	70	Adhesion configuration error	—	✓
Mask 2-2	071:FLN cfg ERR	Alarm out mask 2	71	Flow noise configuration error	—	✓
Mask 2-2	072:Log not start	Alarm out mask 2	72	Data logging not started	—	✓
Mask 2-2	080:AO 1 saturate	Alarm out mask 2	80	Analog output 1 saturated	—*2	✓
Mask 2-2	081:AO 2 saturate	Alarm out mask 2	81	Analog output 2 saturated	✓	✓
Mask 2-2	082:Pls 1 saturate	Alarm out mask 2	82	Pulse output 1 saturated	✓	✓
Mask 2-2	083:Pls 2 saturate	Alarm out mask 2	83	Pulse output 2 saturated	✓	✓
Mask 2-2	084:AI saturate	Alarm out mask 2	84	Analog input saturated	✓	✓
Mask 2-2	085:Cable miscon	Alarm out mask 2	85	Cable misconnect	—	✓
Mask 2-2	086:Coil insulation	Alarm out mask 2	86	Coil insulation warning	✓	✓
Mask 2-2	131:Trans mismatch	Alarm out mask 2	131	Transmitter type mismatch	—	✓
Mask 3-1	087:Adhesion lv 3	Alarm out mask 3	87	Adhesion over level 3	✓	✓
Mask 3-1	088:LC warn	Alarm out mask 3	88	Low conductivity warning	✓	✓
Mask 3-1	089:Insu detect	Alarm out mask 3	89	Insulation detection	✓	✓
Mask 3-1	090:FLN over lv 3	Alarm out mask 3	90	Flow noise over level 3	✓	✓
Mask 3-1	091:FLN over lv 4	Alarm out mask 3	91	Flow noise over level 4	✓	✓
Mask 3-1	092:AZ warn	Alarm out mask 3	92	Autozero warning	—	✓
Mask 3-1	093:Verif warn	Alarm out mask 3	93	Verification warning	✓	✓
Mask 3-1	094:Fact noise warn	Alarm out mask 3	94	Factory noise warning	✓	✓
Mask 3-1	095:Simulate active	Alarm out mask 3	95	Simulation active	—	✓
Mask 3-1	096:AO 1 fix	Alarm out mask 3	96	Analog output 1 fixed	—	✓
Mask 3-1	097:AO 2 fix	Alarm out mask 3	97	Analog output 2 fixed	—	✓
Mask 3-1	098:Pls 1 fix	Alarm out mask 3	98	Pulse output 1 fixed	—	✓
Mask 3-1	099:Pls 2 fix	Alarm out mask 3	96	Pulse output 2 fixed	—	✓
Mask 3-1	100:AI fix	Alarm out mask 3	100	Analog input fixed	—	✓

Display		HART			Default value	Attribute
Parameter name	Alarm name	Parameter name	Alarm name			
Mask 3-2	101:Param restore run	Alarm out mask 3	101	Parameter restore running	✓	✓
Mask 3-2	102:Disp over	Alarm out mask 3	102	Display over warning	✓	✓
Mask 3-2	103:SD size warn	Alarm out mask 3	103	microSD card size warning	✓	✓
Mask 3-2	104:Bkup incmplt	Alarm out mask 3	104	Parameter backup incomplete	—	✓
Mask 3-2	105:SD mismatch	Alarm out mask 3	105	microSD card mismatch	✓	✓
Mask 3-2	106:SD removal ERR	Alarm out mask 3	106	microSD card removal procedure error	✓	✓
Mask 3-2	120:Watchdog* <sup>1</sup>	Alarm out mask 3	120	Watchdog* <sup>1</sup>	✓	✓
Mask 3-2	121:Power off* <sup>1</sup>	Alarm out mask 3	121	Power off* <sup>1</sup>	✓	✓
Mask 3-2	122:Inst power FAIL* <sup>1</sup>	Alarm out mask 3	122	Instant power failure* <sup>1</sup>	✓	✓
Mask 3-2	123:Param bkup run	Alarm out mask 3	123	Parameter backup running	✓	✓
Mask 3-2	124:Data log run	Alarm out mask 3	124	Data logging running	✓	✓
Mask 4-1	130:DevID not enter	Alarm out mask 4	130	Device ID not entered	✓	✓

\*1: Recorded in the alarm record regardless of the settings of the alarm notification mask function.

\*2: When Main soft rev (Main board revision/Main soft rev) is R2.01.01 or earlier, the default value is "✓: Masked".

■ Alarm record mask function

Display		HART			Default value	Attribute
Parameter name	Alarm name	Parameter name	Alarm name			
—	010:Main CPU FAIL	—	10	Main board CPU failure	—	—
—	011:Rev calc FAIL	—	11	Reverse calculation failure	—	—
—	012:Main EEP FAIL	—	12	Main board EEPROM failure	—	—
Mask 1-1	013:Main EEP dfft	Alarm record mask 1	13	Main board EEPROM default	—	✓
—	014:Snsr bd FAIL	—	14	Sensor board failure	—	—
—	015:Snsr comm ERR	—	15	Sensor communication error	—	—
—	016:AD 1 FAIL[Sig]	—	16	A/D1 failure[Signal]	—	—
—	017:AD 2 FAIL[Excit]	—	17	A/D2 failure[Exciter]	—	—
—	018:Coil open	—	18	Coil open	—	—
—	019:Coil short	—	19	Coil short	—	—
Mask 1-2	021:PWM 1 stop	Alarm record mask 1	21	PWM1 stop	—	✓
Mask 1-2	022:PWM 2 stop	Alarm record mask 1	22	PWM2 stop	—	✓
Mask 1-2	023:Opt bd mismatch	Alarm record mask 1	23	Option board mismatch	—	✓
Mask 1-2	024:Opt bd EEP FAIL	Alarm record mask 1	24	Option board EEPROM failure	—	✓
Mask 1-2	025:Opt bd A/D FAIL	Alarm record mask 1	25	Option board A/D failure	—	✓
Mask 1-2	026:Opt bd SPI FAIL	Alarm record mask 1	26	Option board SPI failure	—	✓
—	027:Restore FAIL	—	27	Parameter restore incomplete	—	—
Mask 1-2	028:Ind bd FAIL	Alarm record mask 1	28	Indicator board failure	—	✓
Mask 1-2	029:Ind bd EEP FAIL	Alarm record mask 1	29	Indicator board EEPROM failure	—	✓
Mask 1-2	030:LCD drv FAIL	Alarm record mask 1	30	LCD driver failure	—	✓
Mask 1-2	031:Ind bd mismatch	Alarm record mask 1	31	Indicator board mismatch	—	✓
Mask 1-2	032:Ind comm ERR	Alarm record mask 1	32	Indicator communication error	—	✓
Mask 1-2	033:microSD FAIL	Alarm record mask 1	33	microSD failure	—	✓
Mask 2-1	050:Signal overflow	Alarm record mask 2	50	Signal overflow	—	✓
Mask 2-1	051:Empty detect	Alarm record mask 2	51	Empty pipe detection	—	✓
Mask 2-1	052:H/L HH/LL alm	Alarm record mask 2	52	H/L or HH/LL alarm	—	✓
Mask 2-1	053:Adh over lv 4	Alarm record mask 2	53	Adhesion over level 4	—	✓
—	060:Span cfg ERR	—	60	Span configuration error	✓	—
—	061:PV F cfg ERR	—	61	PV flow select configuration error	✓	—
—	062:AO 1 4-20 lmt	—	62	Analog output 1 4-20mA limit error	✓	—
—	063:AO 2 4-20 lmt	—	63	Analog output 2 4-20 mA limit error	✓	—

Display		HART			Default value	Attribute
Parameter name	Alarm name	Parameter name	Alarm name			
—	064:AO 1 mlt rng	—	64	Analog output 1 multi range error	✓	—
—	065:H/L cfg ERR	—	65	H/L HH/LL configuration error	✓	—
—	066:Density cfg ERR	—	66	Density configuration error	✓	—
—	067:Pls 1 cfg ERR	—	67	Pulse output 1 configuration error	✓	—
—	068:Pls 2 cfg ERR	—	68	Pulse output 2 configuration error	✓	—
—	069:Nomi size cfg	—	69	Nominal size configuration error	✓	—
—	070:Adh cfg ERR	—	70	Adhesion configuration error	✓	—
—	071:FLN cfg ERR	—	71	Flow noise configuration error	✓	—
—	072:Log not start	—	72	Data logging not started	✓	—
—	080:AO 1 saturate	—	80	Analog output 1 saturated	✓	—
—	081:AO 2 saturate	—	81	Analog output 2 saturated	✓	—
—	082:Pls 1 saturate	—	82	Pulse output 1 saturated	✓	—
—	083:Pls 2 saturate	—	83	Pulse output 2 saturated	✓	—
—	084:AI saturate	—	84	Analog input saturated	✓	—
Mask 2-2	085:Cable miscon	Alarm record mask 2	85	Cable misconnect	—	✓
—	086:Coil insulation	—	86	Coil insulation warning	✓	—
—	131:Trans mismatch	—	131	Transmitter type mismatch	✓	—
—	087:Adhesion lv 3	—	87	Adhesion over level 3	✓	—
—	088:LC warn	—	88	Low conductivity warning	✓	—
—	089:Insu detect	—	89	Insulation detection	✓	—
—	090:FLN over lv 3	—	90	Flow noise over level 3	✓	—
—	091:FLN over lv 4	—	91	Flow noise over level 4	✓	—
—	092:AZ warn	—	92	Autozero warning	✓	—
—	093:Verif warn	—	93	Verification warning	✓	—
—	094:Fact noise warn	—	94	Factory noise warning	✓	—
—	095:Simulate active	—	95	Simulation active	✓	—
—	096:AO 1 fix	—	96	Analog output 1 fixed	✓	—
—	097:AO 2 fix	—	97	Analog output 2 fixed	✓	—
—	098:Pls 1 fix	—	98	Pulse output 1 fixed	✓	—
—	099:Pls 2 fix	—	99	Pulse output 2 fixed	✓	—
—	100:AI fix	—	100	Analog input fixed	✓	—
—	101:Param restore run	—	101	Parameter restore running	✓	—
—	102:Disp over	—	102	Display over warning	✓	—
—	103:SD size warn	—	103	microSD card size warning	✓	—
—	104:Bkup incmplt	—	104	Parameter backup incomplete	✓	—
—	105:SD mismatch	—	105	microSD card mismatch	✓	—
—	106:SD removal ERR	—	106	microSD card removal procedure error	✓	—

Display		HART			Default value	Attribute
Parameter name	Alarm name	Parameter name	Alarm name			
—	120:Watchdog <sup>*1</sup>	—	120	Watchdog <sup>*1</sup>	—	—
—	121:Power off <sup>*1</sup>	—	121	Power off <sup>*1</sup>	—	—
—	122:Inst power FAIL <sup>*1</sup>	—	122	Instant power failure <sup>*1</sup>	—	—
—	123:Param bkup run	—	123	Parameter backup running	✓	—
—	124:Data log run	—	124	Data logging running	✓	—
Mask 3-1	130:DevID not enter	Alarm record mask 3	130	Device ID not entered	✓	✓

\*1: Recorded in the alarm record regardless of the settings of the alarm notification mask function.

### 4.8.6 Burnout Direction Display

The burnout function sets an analog output direction when a CPU failure occurs. The analog output direction at burnout can be checked with the following parameters.

**Menu path**

<b>Display</b>	Device setup ► Diag/Service ► H/L alarm cfg ► 4-20 burnout
<b>HART</b>	Diagnostic root menu ► Status/Self test ► Burn out

Displays burn out direction

Selection		Description
Display	HART	
High	High	Outputs 21.6 mA or more at burnout.
Low	Low	Outputs 2.4 mA or less at burnout.

### NOTE

If the optional code C1 or C2 is selected, the burnout direction is set to “Low”. Otherwise, the direction is set to “High”.

Also, the burnout direction can be changed with the hardware burnout switch. For details about the hardware burnout switch, be sure to refer to the Installation Manual.



## 4.9 Display

### 4.9.1 Language Setting

The language to be shown on the display can be selected from nine languages. Select the desired display language from the languages that are included in the language package specified at the time of order. This setting can be configured with the following parameters.

#### ■ Selecting language

**Menu path**

<b>Display</b>	Device setup ► Language
<b>HART</b>	Device root menu ► Detailed setup ► Display ► Display operation configuration ► Language

This parameter specifies the language to be used on the display. From the table below, select the language to be used on the display.

Selection		Description
Display	HART	
English	English	Package 1: Japanese, English, French, German, Italian, Spanish, Portuguese, Russian  Package 2: English, Chinese
French	French	
German	German	
Italian	Italian	
Spanish	Spanish	
Portuguese	Portuguese	
Russian	Russian	
Chinese	Chinese	
Japanese	Japanese	

#### ■ Display of language package

**Menu path**

<b>Display</b>	Device setup ► Detailed setup ► Display set ► Optional config ► Language package
<b>HART</b>	Device root menu ► Detailed setup ► Display ► Display operation configuration ► Language package

This parameter indicates the language package for the display.

## 4.9.2 Display Item Setting

This product can show up to eight items on the display by scrolling it. Each display item is to be set to the eight-line mode.

This setting can be configured with the following parameters.

### Menu path

<b>Display</b>	Device setup ▶ Detailed setup ▶ Display set ▶ Line select ▶ (see below)
<b>HART</b>	Device root menu ▶ Detailed setup ▶ Display ▶ Line select ▶ (see below)

Parameter		Description
Display	HART	
Line 1	Display select1	Specifies item 1 to be shown on the display.
Line 2	Display select2	Specifies item 2 to be shown on the display.
Line 3	Display select3	Specifies item 3 to be shown on the display.
Line 4	Display select4	Specifies item 4 to be shown on the display.
Line 5	Display select5	Specifies item 5 to be shown on the display.
Line 6	Display select6	Specifies item 6 to be shown on the display.
Line 7	Display select7	Specifies item 7 to be shown on the display.
Line 8	Display select8	Specifies item 8 to be shown on the display.

From the table below, select the items to be shown on the display.

Selection		Description
Display	HART	
None	None	Does not display items (item 1 is not selectable).
Flow rate(%)	Flow rate(%)	Displays the flow rate for the span of the PV-mapped process value of Subsection 4.1.2.
PV*2	PV	Displays the PV-mapped process value of Subsection 4.1.2.
Velocity*2	Velocity	Displays the flow velocity.
Volume flow	Volume flow	Displays the volumetric flow rate.
Mass flow	Mass flow	Displays the mass flow rate.
Flow rate(%Bar)	Flow rate(%Bar)	Displays the flow rate for the span of the PV-mapped process value of Subsection 4.1.2 by using a bar graph.
Calorie	Calorie	Displays the calorie. (Only available for AXG, not for AXW)
Totalizer 1*1	Totalizer1	Displays the totalized value of totalizer 1.
Totalizer 2*1	Totalizer2	Displays the totalized value of totalizer 2.
Totalizer 3*1	Totalizer3	Displays the totalized value of totalizer 3.
Tag number	Tag number	Displays the tag number.
Long tag	Long tag	Displays the long tag.
Commun protocol	Commun Protocol	Displays the communication protocol.
Adhesion	Adhesion	Displays the adhesion level of the electrode adhesion detecting function.
Analog out 1	Analog out1	Displays the current value of analog output 1
Analog out 2	Analog out2	Displays the current value of analog output 2 (Only available for AXG, not for AXW)
Flow noise level	Flow noise level	Displays the noise level of the flow noise diagnosis function. (Only available for AXG, not for AXW)
Totalizer 1 count*1*3	Totalizer1 count	Displays the count value of totalizer 1.
Totalizer 2 count*1*3	Totalizer2 count	Displays the count value of totalizer 2.
Totalizer 3 count*1*3	Totalizer3 count	Displays the count value of totalizer 3.

\*1: The upper/lower limits of the totalized value on the display are limited by the number of digits that can be displayed according to the settings of the decimal point position.  
 “For example, if the decimal point position of totalizer 3 is set to decimal point 2, the upper and lower limits of totalizer 3 are +999999.99 and -999999.99.  
 For details about decimal-point position setting, refer to Subsection 4.9.3.  
 The upper and lower limits of the totalized count value are +99999999 and -99999999.”

When the totaled value and the totaled count exceed the upper and lower limit values, the behavior of the displayed value depends on the revision of Main soft rev (Main board revision / Main soft rev) and Ind soft rev (Indicator board revision / Ind soft rev).

“For details about the operation of the totalizer, refer to Subsection 4.2.2.

If the totaled value is reset to 0, the totaled value on the display may be different from the totaled value in Subsection 4.2.2.

This is because the number of digits that can be displayed is different for both values. When re-totalizing, use the reset/ preset function for the totaled value.”

- \*2: The behavior of the displayed value depends on the revision of Main soft rev (Main board revision / Main soft rev) and Ind soft rev (Indicator board revision / Ind soft rev). For detail of the displayed value, refer to Subsection 4.1.3.
- \*3: Available for Main soft rev (Main board revision/Main soft rev) R2.02.01 or later and Ind soft rev (Indicator board revision/Ind soft rev) R2.02.01 or later.

### 4.9.3 Decimal-point Position Setting

The number of decimal places can be set to the automatic adjustment or fix mode for the PV-mapped totaled value or process value of Subsection 4.1.2.

This setting can be configured with the following parameters.

**Menu path**

<b>Display</b>	Device setup ► Detailed setup ► Display set ► Disp format ► (see below)
<b>HART</b>	Device root menu ► Detailed setup ► Display ► Display format ► (see below)

Parameter		Description
Display	HART	
Format PV	Display format PV	Specifies the decimal-point position for the PV-mapped process value of Subsection 4.1.2.
Format total 1	Display format total 1	Specifies the decimal-point position for the totaled value of totalizer 1.
Format total 2	Display format total 2	Specifies the decimal-point position for the totaled value of totalizer 2.
Format total 3	Display format total 3	Specifies the decimal-point position for the totaled value of totalizer 3.

From the table below, select the position of the decimal point.  
Process variable

Selection		Description
Display	HART	
Auto	Auto	Automatically adjusts the number of digits after the decimal point with the PV-mapped process value.*1
0 digit	0 digit	Fixes the number of decimal places to “0”.
1 digit	1 digit	Fixes the number of decimal places to “1”.
2 digit	2 digit	Fixes the number of decimal places to “2”.
3 digit	3 digit	Fixes the number of decimal places to “3”.
4 digit	4 digit	Fixes the number of decimal places to “4”.
5 digit	5 digit	Fixes the number of decimal places to “5”.
Auto 2*	Auto 2*	Automatically adjusts the number of digits after the decimal point with the span of the PV-mapped process value.*2

- \*: Available for Main soft rev (Main board revision/Main soft rev) R2.02.01 or later and Ind soft rev (Indicator board revision/Ind soft rev) R2.02.01 or later.

Totalized value

Selection		Description
Display	HART	
Auto	Auto	Automatically adjusts the number of digits after the decimal point with a totalized value.
0 digit	0 digit	Fixes the number of decimal places to "0".
1 digit	1 digit	Fixes the number of decimal places to "1".
2 digit	2 digit	Fixes the number of decimal places to "2".
3 digit	3 digit	Fixes the number of decimal places to "3".
4 digit	4 digit	Fixes the number of decimal places to "4".
5 digit	5 digit	Fixes the number of decimal places to "5".
6 digit	6 digit	Fixes the number of decimal places to "6".
7 digit	7 digit	Fixes the number of decimal places to "7".

\*1: When "Auto" is selected, the display format is automatically switched in response to the process value selected for PV. The table below shows details.

Judgment range		Supported display format
	$ \text{process value}  \geq 100000$	0digit
100000	$> \text{process value}  \geq 10000.0$	1digit
10000.0	$> \text{process value}  \geq 1000.00$	2digit
1000.00	$> \text{process value}  \geq 100.000$	3digit
100.000	$> \text{process value}  \geq 10.0000$	4digit
10.0000	$> \text{process value}  \geq 0.00000$	5digit

Since the display format is switched in response to the process values, the display format may be switched when the product is used near the threshold listed in the above table.

\*2: When "Auto 2" is selected, the display format is automatically switched in response to the span value of the process selected for PV. The table below shows details.

Judgment range		Supported display format
	$ \text{span value}  > 900$	0digit
900	$\geq  \text{span value}  > 90$	1digit
90	$\geq  \text{span value}  > 9$	2digit
9	$\geq  \text{span value}  > 0$	3digit

Since the display format is switched in response to span values of the process, the display format is not changed as long as the span is not changed.

### 4.9.4 Display Line Count and Scroll Settings

This product can show up to eight items on the display by scrolling, with four lines max. shown at a time. The scroll method can be selected from the automatic display switching or the display switching using the IR switch.

This setting can be configured with the following parameters.

**Menu path**

<b>Display</b>	Device setup ▶ Detailed setup ▶ Display set ▶ Optional config ▶ (see below)
<b>HART</b>	Device root menu ▶ Detailed setup ▶ Display ▶ Display operation configuration ▶ (see below)

Parameter		Description
Display	HART	
Line mode	Display line	Specifies the number of lines to be shown on the display.*1
Scroll mode	Display scroll	Specifies the display scroll method.*2

\*1: From the table below, select the number of display lines.  
 The font size is automatically adjusted depending on the number of the displayed line.

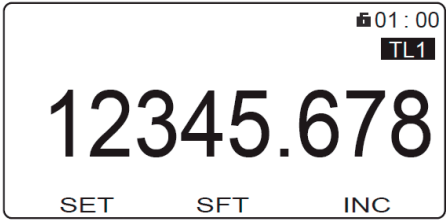
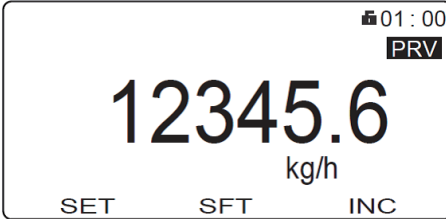
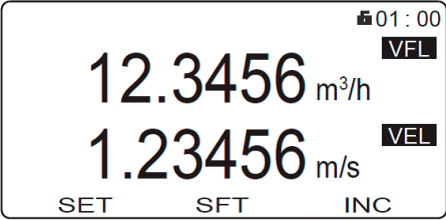
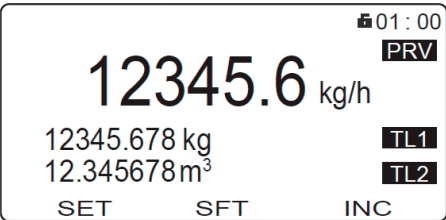
Selection		Description
Display	HART	
1 line(big)	1 Line(Big)	1-line display without unit. The numeric value is displayed in a large font.  <p style="text-align: right;">F0427.ai</p>
1 line	1 Line	1-line display with unit.  <p style="text-align: right;">F0428.ai</p>
2 line	2 Line	2-line display with units  <p style="text-align: right;">F0429.ai</p>
3 line	3 Line	3-line display with units  <p style="text-align: right;">F0430.ai</p>

Selection		Description
Display	HART	
4 line	4 Line	4-line display with units. <div style="border: 1px solid black; padding: 5px; margin-top: 10px;"> <p>01:00                          12345.6 kg/h MFL                          12345.6 MJ/h CAL                          12345.6 kg/h PRV                          12345.678 kg TL1                          SET SFT INC</p> </div> <p style="text-align: right; font-size: small;">F0431.ai</p>

\*2: From the table below, select the scroll method.

Selection		Description
Display	HART	
Off	Off	Does not scroll.
Manual	Manual	Specifies to the scroll using the IR switch.
Auto(2 s)	Auto(2s)	Specifies to the automatic scroll at 2-second intervals.
Auto(4 s)	Auto(4s)	Specifies to the automatic scroll at 4-second intervals.
Auto(8 s)	Auto(8s)	Specifies to the automatic scroll at 8-second intervals.

**NOTE**

The default value of the scroll method (Display scroll/Scroll mode) is “Off”.  
 If the value of the scroll method is set to “Off”, the 5th line and beyond cannot be checked on the display.  
 To display the 5th line and beyond, set an option other than “Off”.

**NOTE**

When Main soft rev (Main board revision/Main soft rev) is R2.01.01 or earlier, the default value of the scroll method (Display scroll/Scroll mode) is “Manual”.  
 If the value of the scroll method is set to “Manual”, the display line is scrolled each time the infrared switch [INC] reacts.

### 4.9.5 Trend Graph Setting

The trend graph display function displays the time change of the selected item as a trend graph. Up to four items can be selected for a trend graph. A trend graph is scaled automatically, and the time axis flows from the left to the right.

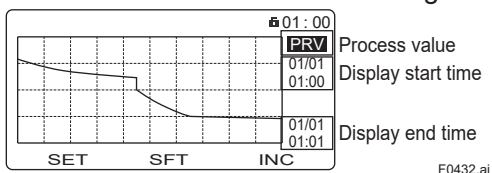

### (1) Trend graph display setting

The process value and low limit value/high limit value that can be shown in a trend graph are as follows:

Process value	Display	Low limit	High limit
Flow rate (%)	FLP	0%	100%
PV	PRV	0	Span value specified in Subsection 4.1.5
Flow velocity	VEL		
Volumetric flow rate	VFL		
Mass flow rate	MFL		
Calorie*	CAL		
Analog output 1	AO1	4 mA	20 mA
Analog output 2*	AO2		
Totalizer 1	TL1	Preset value specified in Subsection 4.2.7	Target value of the totalizer specified in Subsection 4.2.3
Totalizer 2	TL2		
Totalizer 3	TL3		

\*: Only available for AXG, not for AXW

A trend graph can be set with the following parameters.

#### Menu path

<b>Display</b>	Device setup ► Detailed setup ► Display set ► Optional config ► Display mode
<b>HART</b>	Device root menu ► Detailed setup ► Display ► Display operation configuration ► Display measure mode

From the table below, select the trend graph display.

Selection		Description
Display	HART	
Normal	Normal	Does not display a trend graph (normal display).
Trend	Trend	Displays a trend graph.

## NOTE

The trend graph display function is not synchronized with the multi range and the forward/reverse range.

### (2) Trend graph display item setting

This setting can be configured with the following parameters.

#### Menu path

<b>Display</b>	Device setup ► Detailed setup ► Display set ► Trend select ► (see below)
<b>HART</b>	Device root menu ► Detailed setup ► Display ► Trend select ► (see below)

Parameter		Description
Display	HART	
Trend 1	Trend select 1	Specifies item 1 to be shown in a trend graph.
Trend 2	Trend select 2	Specifies item 2 to be shown in a trend graph.
Trend 3	Trend select 3	Specifies item 3 to be shown in a trend graph.
Trend 4	Trend select 4	Specifies item 4 to be shown in a trend graph.

From the table below, select the display item of trend graph.

Selection		Description
Display	HART	
None	None	Does not set any items (item 1 is not selectable).
Flow rate(%)	Flow rate(%)	Specifies the flow rate for the span of the PV-mapped process value of Subsection 4.1.2.

Selection		Description
Display	HART	
PV	PV	Specifies the PV-mapped process value of Subsection 4.1.2.
Velocity	Velocity	Specifies the display item to the flow velocity.
Volume flow	Volume flow	Specifies the display item to the volumetric flow rate.
Mass flow	Mass flow	Specifies the display item to the mass flow rate.
Calorie	Calorie	Specifies the display item to calorie. (Only available for AXG, not for AXW)
Analog out 1	Analog out1	Specifies to the low limit of analog output 1.
Analog out 2	Analog out2	Specifies to the low limit of analog output 2. (Only available for AXG, not for AXW)
Totalizer 1	Totalizer1	Specifies the totalized value of totalizer 1.
Totalizer 2	Totalizer2	Specifies the totalized value of totalizer 2.
Totalizer 3	Totalizer3	Specifies the totalized value of totalizer 3.

### (3) Trend graph high/low limit setting

This setting can be configured with the following parameters.

#### Menu path

<b>Display</b>	Device setup ► Detailed setup ► Display set ► Optional config ► (see below)
<b>HART</b>	Device root menu ► Detailed setup ► Display ► Display operation configuration ► (see below)

Parameter		Description
Display	HART	
Trend offln URV	Trend offline urv	Specifies the high limit to display in a trend graph.
Trend offln LRV	Trend offline lrv	Specifies the low limit to display in a trend graph.

## 4.9.6 Update Period Setting

The update period of the process value and the trend graph on the display can be set. This setting can be configured with the following parameters.

#### Menu path

<b>Display</b>	Device setup ► Detailed setup ► Display set ► Optional config ► Period
<b>HART</b>	Device root menu ► Detailed setup ► Display ► Display operation configuration ► Display period

From the table below, select the update period.

Selection		Description
Display	HART	
0.2 s	0.2s	Sets the update period to 0.2 sec.
0.4 s	0.4s	Sets the update period to 0.4 sec.
1.0 s	1.0s	Sets the update period to 1 sec.
2.0 s	2.0s	Sets the update period to 2 sec.
4.0 s	4.0s	Sets the update period to 4 sec.
8.0 s	8.0s	Sets the update period to 8 sec.



## 4.9.7 Other Settings

### (1) Display contrast setting

The contrast of the display can be adjusted to 11 levels (+5 to -5). This setting can be configured with the following parameters.

#### Menu path

<b>Display</b>	Device setup ► Detailed setup ► Display set ► Optional config ► Contrast
<b>HART</b>	Device root menu ► Detailed setup ► Display ► Display operation configuration ► Display contrast

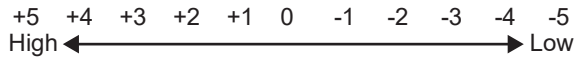

### (2) Display damping time constant setting

This function can specify the damping time constant for the display independently of that specified in Subsection 4.1.6. This setting can be configured with the following parameters.

#### Menu path

<b>Display</b>	Device setup ► Detailed setup ► Display set ► Optional config ► Damp
<b>HART</b>	Device root menu ► Detailed setup ► Display ► Display operation configuration ► Display damping

## NOTE

The damping time constant of the display is effective only for the display. Refer to Subsection 4.1.6 to specify the damping time constant for the output of the physical quantity.

### (3) Date display format setting

The date display format can be set. This setting can be configured with the following parameters.

#### Menu path

<b>Display</b>	Device setup ► Detailed setup ► Display set ► Optional config ► Format date
<b>HART</b>	Device root menu ► Detailed setup ► Display ► Display operation configuration ► Display format date

From the table below, specify the date display format.

Selection		Description
Display	HART	
MM/DD/YYYY	MM/DD/YYYY	Displays the date as “month/day/year”.
DD/MM/YYYY	DD/MM/YYYY	Displays the date as “day/month/year”.
YYYY/MM/DD	YYYY/MM/DD	Displays the date as “year/month/day”.

**(4) Display black/white inverse setting**

The black/white inverse is available for the display.  
This setting can be configured with the following parameters.

**Menu path**

<b>Display</b>	Device setup ► Detailed setup ► Display set ► Optional config ► Inversion
<b>HART</b>	Device root menu ► Detailed setup ► Display ► Display operation configuration ► Display inversion

From the table below, select the display black/white inverse mode.

Selection		Description
Display	HART	
Normal	Normal	Does not set the display to the black/white inverse mode. (Character color: Black, Background color: White)
Invert	Invert	Sets the display to the black/white inverse mode. (Character color: White, Background color: Black)

**(5) Display squawk setting (squawk)**

The back light of the display can be blinked (squawked) at 4-second intervals to identify a communicating product if a number of the same model is installed.  
This setting can be configured with the following parameters.

**Menu path**

<b>Display</b>	Device setup ► Diag/Service ► Disp indicator ► Squawk
<b>HART</b>	Maintenance root menu ► Display indication ► Squawk

From the table below, select whether or not to blink the display.

Selection		Description
Display	HART	
Off	Off	Does not blink the display.
On	On	Blinks the display (continuously).
Squawk once	Squawk Once	Blinks the display (only once).

**(6) IR switch function**

This function is available when Main soft rev (Main board revision/Main soft rev) is R2.02.01 or later and Ind soft rev (Indicator board revision/Ind soft rev) is R2.02.01 or later.  
The IR switch function is a function to drive the IR switch for display operation. For the basic operations of the IR switch, refer to Subsection 2.2.1.  
This setting can be configured with the following parameters.

**Menu path**

<b>HART</b>	Device root menu ► Detailed setup ► Display ► Display operation configuration ► IRSW operation
-------------	--

From the table below, select how the IR switch function is to be used.

Selection	Description
Disable	Disables the IR switch function.
Enable	Enables the IR switch function.

**NOTE**

If the IR switch function is set to “Disable”, the switch function is not displayed on the display, and the IR switch cannot be operated.

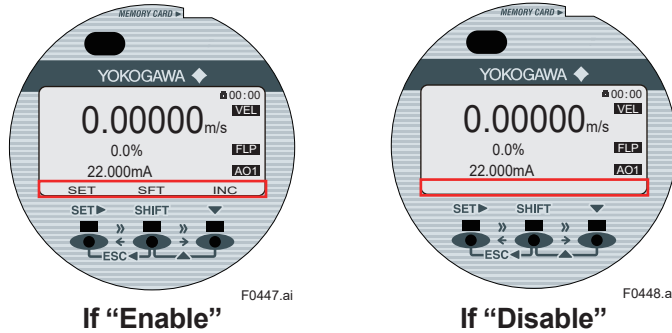

**(7) Time Display Settings**

This function is available when Main soft rev (Main board revision/Main soft rev) is R2.02.01 or later and Ind soft rev (Indicator board revision/Ind soft rev) is R2.02.01 or later.

The item for time shown on the display can be set.

This setting can be configured with the following parameters.

**Menu path**

<b>Display</b>	Device setup ▶ Detailed setup ▶ Display set ▶ Optional config ▶ Time display
<b>HART</b>	Device root menu ▶ Detailed setup ▶ Display ▶ Display operation configuration ▶ Display time

From the table below, select the display time.

Selection		Description
Display	HART	
Current time	Current time	Displays Current time
Operation days	Operation days	Displays Operation days
Off	Off	Hidden

**NOTE**

“Current time” displays “Current time”, the parameter of date and time information. For details about the date and time information, refer to Subsection 4.10.4.

“Operation days” displays only the day (dddd) out of the parameter “Operation time”. For details about the operation time, refer to Subsection 4.10.5.

### 4.9.8 microSD Card Setting

If the optional code MC is selected, the backup parameters and logging data can be used by inserting the dedicated microSD card into the display.  
For details about backing up parameters and logging data, refer to Section 4.13.

#### (1) Removing the microSD card

### IMPORTANT

If the microSD card is removed without executing "Unmount" on the software, it may cause data stored on the microSD card to be erased or the device to operate abnormally.

The microSD card can be removed with the following parameters.

#### Menu path

<b>Display</b>	Device setup ▶ microSD ▶ Unmount
----------------	----------------------------------

From the table below, select whether to remove the microSD card.

Selection	Description
Cancel	Cancels the removal of the microSD card.
Execute	Makes it possible to remove the microSD card in safety.

#### (2) microSD card format

### IMPORTANT

If the format function of this product is not used to format a microSD card, it may cause a device operation failure.

Formatting is possible with the following parameters.

#### Menu path

<b>Display</b>	Device setup ▶ microSD ▶ Format
----------------	---------------------------------

From the table below, select whether to format the microSD card.

Selection	Description
Cancel	Cancels formatting.
Execute	Executes formatting.

#### (3) Checking microSD contents

Data on the microSD card can be checked with the following parameters.

#### Menu path

<b>Display</b>	Device setup ▶ microSD ▶ Contents
----------------	-----------------------------------

#### (4) Checking the property of microSD Card

The total space, available space and file system of the microSD card can be checked with the following parameters.

### ■ Total space

Menu path

Display	Device setup ▶ microSD ▶ Property ▶ Total space
---------	---

### ■ Displaying available space

Menu path

Display	Device setup ▶ microSD ▶ Property ▶ Available space
---------	---

### ■ Displaying file system

Menu path

Display	Device setup ▶ microSD ▶ Property ▶ File system
---------	---

# 4.10 Device Information

## 4.10.1 Order Information

Order information can be specified for this product. If a particular parameter is specified at the time of order, this product is shipped with the parameter specified. If a parameter is not specified at the time of order, that parameter needs to be set by the customer. The model and suffix code are indicated in the following format.

**Sensor:**

AXG □□□ - □□□□□□□□□□□□□□ - □□□□ / □  
 (1) (2) (3)

AXW □□□ - □□□□□□□□□□□□□□ - □□□□ / □  
 (1) (2) (3)

**Transmitter:**

AXG □ A - □□□□□□□□□□ / □  
 (1) (2) (3)

AXW □ A - □□□□□□□□□□ / □  
 (1) (2) (3)

(1) Model code, (2) Suffix code, (3) Optional code

This setting can be configured with the following parameters.

**Menu path**

<b>Display</b>	Device setup ▶ Detailed setup ▶ Device info ▶ Order info ▶ (see below)
<b>HART</b>	Device root menu ▶ Detailed setup ▶ Device information ▶ Order information ▶ (see below)

Parameter		Description
Display	HART	
Tag No	Tag	Specifies the Tag No. Max. 8 characters. (Refer to Section 3.3.)
Long tag	Long tag	Specifies long tag. Max. 8 characters. (Refer to Section 3.3.)
MS code ▶ Model code	Basic model code	Specifies the model code of the integral flowmeter or remote transmitter.
MS code ▶ Suffix config 1	Suffix config 1	Specifies the suffix code of the integral flowmeter or remote transmitter.
MS code ▶ Suffix config 2	Suffix config 2	
MS code ▶ Option 1	Option 1	Specifies the optional code of the integral flowmeter or remote transmitter.
MS code ▶ Option 2	Option 2	
MS code ▶ Option 3	Option 3	
MS code ▶ Option 4	Option 4	
RS MS code ▶ Model code	Remote sensor basic model code	Specifies the model code of the remote sensor.
RS MS code ▶ Suffix config 1	Remote sensor suffix config 1	Specifies the suffix code of the remote sensor.
RS MS code ▶ Suffix config 2	Remote sensor suffix config 2	
RS MS code ▶ Option 1	Remote sensor option 1	Specifies the optional code of the remote sensor.
RS MS code ▶ Option 2	Remote sensor option 2	
RS MS code ▶ Option 3	Remote sensor option 3	
RS MS code ▶ Option 4	Remote sensor option 4	

**Menu path**

<b>Display</b>	Device setup ► Detailed setup ► Device info ► Ver/Num info ► (see below)
<b>HART</b>	Device root menu ► Detailed setup ► Device information ► Version/Number information ► (see below)

Parameter		Description
Display	HART	
Trans serial No	Transmitter serial No	Displays the serial number (device No.) of the transmitter.
Sensor serial No	Sensor serial No	Displays the serial number (device No.) of the sensor.

**NOTE**

When any parameters related to the order information about the product are changed, the order information upon shipment from the manufacturing factory cannot be referred to. To store the order information defined upon shipment from the manufacturing factory, it is recommended to refer to Section 4.13 to make a backup.

### 4.10.2 Device Revision

The revision of the software used for this product can be checked. This information can be viewed with the following parameters.

**Menu path**

<b>Display</b>	Device setup ► Detailed setup ► Device info ► Ver/Num info ► (see below)
<b>HART</b>	Device root menu ► Detailed setup ► Device information ► Version/Number information ► (see below)

Parameter		Description
Display	HART	
Transmitter type	Transmitter type	Displays the type of the transmitter.
Option board ID	Option board ID	Displays the type of the option board.
Main soft rev	Main board revision	Displays the software revision of the main board.
Snsr soft rev	Sensor board revision	Displays the software revision of the sensor board.
Ind soft rev	Indicator board revision	Displays the software revision of the display board.
Hard rev	Hardware rev	Displays the hardware revision of the HART device.
Dev id	Dev id	Displays the HART device ID.

### 4.10.3 Memo Function

Three parameters can be used for the memo function. The memo function can be set to up to 16 characters.

This setting can be configured with the following parameters.

**Menu path**

<b>Display</b>	Device setup ▶ Detailed setup ▶ Device info ▶ Memo ▶ (see below)
<b>HART</b>	Device root menu ▶ Detailed setup ▶ Device information ▶ Memo ▶ (see below)

Parameter		Description
Display	HART	
Memo 1	Memo 1	Specifies memo 1.
Memo 2	Memo 2	Specifies memo 2.
Memo 3	Memo 3	Specifies memo 3.

### 4.10.4 Date and Time Information

The present date and time can be set. The display format for date and time is the format set in Subsection 4.9.7.

This setting can be displayed and configured with the following parameters.

#### ■ Displaying date and time

**Menu path**

<b>Display</b>	Device setup ▶ Detailed setup ▶ Device info ▶ Date/Time ▶ (see below)
<b>HART</b>	Maintenance root menu ▶ Time stamp ▶ (see below)

Parameter		Description
Display	HART	
Current date	Current Date	Displays current date.
Current time	Current Time	Displays current time.

#### ■ Setting date and time

**Menu path**

<b>Display</b>	Device setup ▶ Detailed setup ▶ Device info ▶ Date/Time ▶ (see below)
<b>HART</b>	Maintenance root menu ▶ Time stamp ▶ (see below)

Parameter		Description
Display	HART	
Set date	-	Sets the current date.
Set time	-	Sets the current time.
-	Set Date/Time	Sets the current date/time.



### 4.10.5 Display Operation Time

Displays operation time. Operation time refers to the operation time up to the present from the time when the power was turned on for the first time. However, time is not counted when power is not turned on.

This information can be viewed with the following parameters.

**Menu path**

<b>Display</b>	Device setup ► Detailed setup ► Device info ► Date/Time ► Operation time
<b>HART</b>	Maintenance root menu ► Time stamp ► Operation time

The operation time is displayed in the format of “ddddD hh:mm”. “ddddD” indicates the day, “hh” indicates the hour, and “mm” indicates the minute.

**Example:**

“00031D 12:34”

This example shows that the product has been operated for 31 days, 12 hours, and 34 minutes.

### 4.10.6 Explosion Protection Setting

This function is available when Main soft rev (Main board revision/Main soft rev) is R2.02.01 or later and Ind soft rev (Indicator board revision/Ind soft rev) is R2.02.01 or later.

Whether the product is a standard product or an explosion protection product can be set.

When using an explosion protection sensor, set the following parameter to “Yes”.

**Menu path**

<b>Display</b>	Device setup ► Detailed setup ► Device info ► Order info ► Explosion protection
<b>HART</b>	HART Device root menu ► Detailed setup ► Device information ► Order information ► Explosion protection

From the table below, select explosion protection setting.

Selection		Description
Display	HART	
No	No	No explosion protection setting.
Yes	Yes	Explosion protection.

## 4.11 Self-diagnostic Function

### 4.11.1 Types of Diagnosis Functions

This product has a self-diagnostic function for diagnosing device failures or process states. Diagnostic functions of this product are as follows:

Diagnosis function	Description
Alarm high/low limit function	Displays an alarm when the specified value is exceeded and outputs it as the status output.
Electrode adhesion detection	Diagnoses an electrode adhesion from the resistance value of the electrode, and displays a warning or alarm if adhesion is detected.
Sensor empty check	Checks whether the sensor is in the empty pipe state, and displays an alarm if the empty pipe state is detected.
Misconnection detection	Checks whether the transmitter signal line and the excitation line are correctly connected, and displays a warning if a misconnection is detected.
Verification (device health diagnosis) function	Diagnoses the health of the product, and displays its result.
Electrode insulation deterioration diagnosis	Diagnoses deterioration of insulation from a resistance value of the electrode, and displays a warning if it is detected. (Only available for AXG, not for AXW)
Flow noise diagnosis	Measures a flow noise detected in the sensor, and displays a warning if the measured value exceeds the specified value. (Only available for AXG, not for AXW)
Low conductivity diagnosis	Obtains the conductivity from the resistance value and size of the electrode, and displays a warning if the conductivity falls below the specified value. (Only available for AXG, not for AXW)
Coil insulation diagnosis	Diagnoses the current value of exciting current, and displays warning if insulation is detected.

### 4.11.2 Alarm High/Low Limit Function

The high/low limit function of the alarm displays an alarm when the PV-mapped physical quantity of Subsection 4.1.2 exceeds the specified value. This function also can output an alarm occurrence as a status output.

For details about the status output, refer to Subsection 4.3.9.

As a value to judge an alarm, the following four values can be set: high limit, high-high limit, low limit, and low-low limit.

This setting can be configured with the following parameters.

#### Menu path

<b>Display</b>	Device setup ► Diag/Service ► H/L alarm cfg ► (see below)
<b>HART</b>	Maintenance root menu ► High/Low alarm configuration ► (see below)

Parameter		Description
Display	HART	
High alarm	High alarm	Specifies the high limit to judge an alarm.
Low alarm	Low alarm	Specifies the low limit to judge an alarm.
HH alarm	High high alarm	Specifies the high-high limit to judge an alarm.
LL alarm	Low low alarm	Specifies the low-low limit to judge an alarm.

When the high and low limit alarms are reset, each has a hysteresis. The hysteresis width should be set with the percentage (%) for the span of the PV-mapped physical quantity of Subsection 4.1.2. The hysteresis in each case can be specified with the following parameters.

#### Menu path

<b>Display</b>	Device setup ► Diag/Service ► H/L alarm cfg ► H/L alarm hyst
<b>HART</b>	Maintenance root menu ► High/Low alarm configuration ► Hi/Lo alarm hysteresis

**NOTE**

The alarm “052:H/L HH/LL alm” is masked at the factory shipment. When using this function, be sure to set the alarm notification mask to “Off”. For details about the alarm mask function, refer to Subsection 4.8.5.

The alarm high/low limit function can be configured with the following procedure.

- (1) Specify the high limit, high-high limit, low limit or low-low limit to judge an alarm.
- (2) Specify the hysteresis when alarms are reset.
- (3) Refer to Subsection 4.3.9 to specify the status output function to H/L alarm or HH/LL alarm, if the status output is used for alarm notification.

**Example:**

Span of volumetric flow rate = 300 m<sup>3</sup>/h,  
 High-high limit = 300 m<sup>3</sup>/h, Low-low limit = 25 m<sup>3</sup>/h,  
 High limit value = 250 m<sup>3</sup>/h, Low limit value = 50 m<sup>3</sup>/h,  
 When set to Hysteresis width = 5 %

- (1) Hysteresis value = Span or max. range x Hysteresis width [%]  
 = 300 [m<sup>3</sup>/h] × 5 [%] = 15 [m<sup>3</sup>/h]
- (2-1) Value that causes a high-high limit alarm to be reset  
 = Specified high-high limit value - Hysteresis value  
 = 285 [m<sup>3</sup>/h] (= 300 [m<sup>3</sup>/h] – 15 [m<sup>3</sup>/h])
- (2-2) Value that causes a high limit alarm to be reset  
 = Specified high limit value - Hysteresis value  
 = 235 [m<sup>3</sup>/h] (= 250 [m<sup>3</sup>/h] – 15 [m<sup>3</sup>/h])
- (3-1) Value that causes a low limit alarm to be reset  
 = Specified low limit value + Hysteresis value  
 = 65 [m<sup>3</sup>/h] (= 50 [m<sup>3</sup>/h] + 15 [m<sup>3</sup>/h])
- (3-2) Value that causes a low-low limit alarm to be reset  
 = Specified low-low limit value + Hysteresis value  
 = 40 [m<sup>3</sup>/h] (= 25 [m<sup>3</sup>/h] + 15 [m<sup>3</sup>/h])

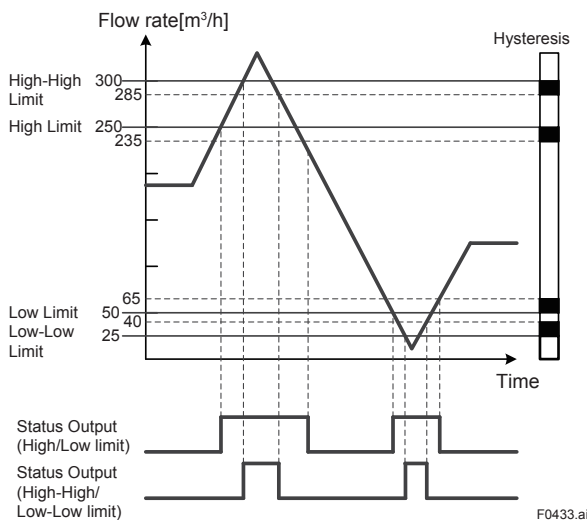

**NOTE**

When the physical quantity to be output is changed, specify the alarm judgment value again.

### 4.11.3 Electrode Adhesion Detection

The electrode adhesion detecting function diagnoses an electrode adhesion with the resistance value of the electrode, and displays a warning or alarm if an adhesion is detected. The electrode adhesion detection is displayed on the display in four levels: level 1 to level 4. A value to judge each level can be specified individually. Display a warning when adhesion exceeds level 3, and an alarm when adhesion exceeds level 4. For details about the alarm and warning, refer to Subsection 4.8.1.

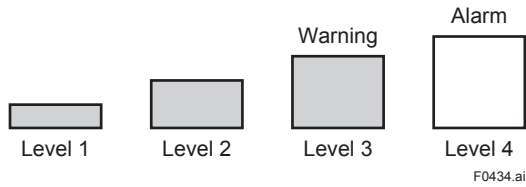

This setting can be configured with the following parameters.

**Menu path**

<b>Display</b>	Device setup ► Diag/Service ► Diagnosis ► Adhesion ► (see below)
<b>HART</b>	Diagnostic rootmenu ► Diagnosis ► Adhesion ► (see below)

Parameter		Description
Display	HART	
Function	Adhesion function	Specifies the use of the electrode adhesion detecting function.*1
Threshold level 1	Adhesion level 1	Specifies the value to judge level 1.
Threshold level 2	Adhesion level 2	Specifies the value to judge level 2.
Threshold level 3	Adhesion level 3	Specifies the value to judge level 3.
Threshold level 4	Adhesion level 4	Specifies the value to judge level 4.
Result ► Value	Result ► Adhesion value	Displays the resistance value of the electrode.
Result ► Status	Result ► Adhesion status	Displays the electrode adhesion detection level.
Check cycle	Adhesion check cycle	Specifies the data update cycle for electrode adhesion detection.

\*1: From the table below, select the use of the electrode adhesion detection function.

Selection		Description
Display	HART	
Disable	Disable	Does not use the electrode adhesion detecting function.
Enable	Enable	Uses the electrode adhesion detecting function.

**NOTE**

If the electrode adhesion detecting function is not used, the electrode resistance value and level are cleared.

**NOTE**

Be sure to use the electrode adhesion detecting function when the sensor is in the full pipe state. If the sensor is in the empty pipe state, the function to detect adhesion may not run normally.

**NOTE**

The electrode adhesion detecting function restricts fluid conductivity. The recommended conductivities are as follows.

Size	Conductivity
2.5 to 10 mm	30 μS/cm or larger
15 to 400 mm (0.5 to 16 in.)	10 μS/cm or larger
500 mm	20 μS/cm or larger

**NOTE**

If the data update cycle for the adhesion detection is shortened, the error of the electrode resistance value increases. Do not change the default value unless especially specified.

### 4.11.4 Sensor Empty Check

The sensor empty check function checks whether the sensor is in the empty pipe state, and displays an alarm if the empty pipe state is detected.

For details about the alarm and warning, refer to Subsection 4.8.1.

This information can be viewed with the following parameters.

**Menu path**

<b>Display</b>	Device setup ▶ Diag/Service ▶ Diagnosis ▶ Empty check ▶ (see below)
<b>HART</b>	Diagnostic root menu ▶ Diagnosis ▶ Empty ▶ (see below)

Parameter		Description
Display	HART	
Empty status	Result ▶ Empty status	Display the result of the sensor empty check function.*1
Electrode voltage A	Electrode voltage A	Displays the voltage of electrode A.
Electrode voltage B	Electrode voltage B	Displays the voltage of electrode B.

\*1: From the table below, check the result of the sensor empty check function.

Selection		Description
Display	HART	
Full	Full	Indicates that the sensor is in the full pipe state.
Empty	Empty	Indicates that the sensor is in the empty pipe state.

**IMPORTANT**

- If the sensor is in the empty pipe state, output fluctuation or empty check alarm may occur. Be sure to use this product being filled with liquid fully.
- The empty check is determined by measuring the resistance between the electrode and the ground. For that reason, the empty pipe state may not be detected due to the piping condition, electrode condition, and environmental noise. In particular, note that the empty check function may not operate properly for high-viscosity fluids and adhesive fluids.
- It takes 10 to 15 minutes to diagnose the empty pipe state. Other process alarms may occur before the empty check alarm occurs after the pipe is in the empty pipe state.

### 4.11.5 Wiring Connection Diagnosis

The wiring connection diagnostic function diagnoses whether the signal line and the excitation line between the remote type sensor and transmitter are correctly connected, and displays a warning if a misconnection is detected.

For example, if there are two sets (A and B) of remote sensors and remote transmitters, this function checks whether the signal line of transmitter A is misconnected to the signal terminal of sensor B, or the excitation line of transmitter A is misconnected to the excitation terminal of sensor B.

It takes approximately 10 seconds to diagnose the wiring connection.

For details about the alarm and warning, refer to Subsection 4.8.1.

This setting can be configured with the following parameters.

**Menu path**

<b>Display</b>	Device setup ► Diag/Service ► Diagnosis ► (see below)
<b>HART</b>	Diagnostic root menu ► Diagnosis ► (see below)

Parameter		Description
Display	HART	
Diagnostic execute	Diagnostic Exe	Specifies the use of the wiring connection diagnostic function.*1
Diagnostic output	Diagnostic output	Specifies the output to use the wiring connection diagnostic function.*2

\*1: From the table below, select the use of the wiring connection diagnostic function.

Selection		Description
Display	HART	
Connect check exe	Connection check execute	Starts the wiring connection diagnostic function.

\*2: From the table below, select the output for which the wiring connection diagnostic function is executed.

Selection		Analog output	Totalizer	Pulse output	Frequency output
Display	HART				
Zero	Zero	0% output	Input 0 (Output fixed)	0 pps	0% output
Measured value	Measured value	Output of calculated value (Undefined)	Totalization of calculated value (Undefined)	Output of calculated value (Undefined)	Output of calculated value (Undefined)
Hold	Hold	Fixes the last valid value before the diagnosis starts.	Totalizes the last valid value before the diagnosis starts.	Fixes the last valid value before the diagnosis starts.	Fixes the last valid value before the diagnosis starts.

### IMPORTANT

- Before using the wiring connection diagnostic function, be sure to disconnect this product from the control loop.
- When the wiring misconnection diagnostic function is used, the analog output and pulse output are not output correctly.

**NOTE**

When using the wiring connection diagnostic function, the following conditions must be satisfied. If the conditions are not satisfied, this product may not correctly diagnose the wiring connection state.

- The sensor is in the full pipe state.
- No influence of noise.
- The magnetic flowmeter transmitter and AM012 (calibrator) are not connected.

### 4.11.6 Verification (Device Health Diagnosis) Function

The verification function diagnoses the health of the product and displays the diagnosis result. It takes about 15 minutes to complete the verification function, and the progress of the verification function can be checked via the bar graph and the remaining time on the display.

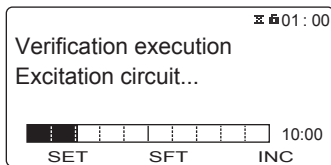

This function can inspect conditions of the magnetic circuit, excitation circuit and calculation circuit, and executes the device health diagnosis of the product based on their internal alarm record along with their wiring misconnection. This function evaluates the diagnosis result based on the conditions of the product and shows “Passed” if no problem is found or “Failed” if a problem is found on the display.

The following execution results are shown on the display.

- **Examples of “Passed” results**

VF check results	Passed
VF Operation time	00001D 10:01
Magnetic circuit result	Passed
Exciting circuit result	Passed
Calculation circuit result	Passed
Device status result	Passed
Connection status result	Passed

- **Examples of “Failed” results**

VF check results	Failed
VF Operation time	00001D 10:01
Magnetic circuit result	Passed
Exciting circuit result	Passed
Calculation circuit result	Failed
Device status result	Passed
Connection status result	Passed

Contact Yokogawa service center if the “Failed” message is displayed for items from “Magnetic circuit result” to “Device status result”.

If “Failed” is displayed for “Connection status result”, check for wiring misconnection between the sensor and transmitter (refer to Subsection 4.11.5 for detail) and damage on the cables.

The verification function can be used in two ways depending on the state of the fluid; one state where a fluid is flowing and another state where no fluid is flowing.

The two diagnosis results (current and previous) are stored in the device memory, and they can be checked later.

If the verification function is used, the following results can be displayed.

Total judgment result	Calculation circuit diagnosis result
Device operation time at the start of verification execution	Device alarm diagnosis result
Magnetic circuit diagnosis result	Wiring connection diagnosis result
Excitation circuit diagnosis result	

This setting can be configured with the following parameters.

**Menu path**

<b>Display</b>	Device setup ▶ Diag/Service ▶ Diagnosis ▶ (see below)
<b>HART</b>	Maintenance root menu ▶ Verification ▶ (see below)

Parameter		Description
Display	HART	
Diagnostic output	Diagnostic output	Specifies the output to execute the verification function.*1

**Menu path**

<b>Display</b>	Device setup ▶ Diag/Service ▶ Verification ▶ (see below)
<b>HART</b>	Maintenance root menu ▶ Verification ▶ (see below)

Parameter		Description
Display	HART	
Mode	VF mode	Specifies the fluid state when performing the verification function.*2
Execute	Verification Exe	Specifies the execution of the verification function.*3
VF No	VF No	Specifies the diagnosis result display time.*4
VF target select*	VF target select*	Specifies the target for diagnosis*5
Result	Result	Displays the diagnosis result of the time set by the VF number.*6

\*: Available for Main soft rev (Main board revision/Main soft rev) R2.02.01 or later and Ind soft rev (Indicator board revision/Ind soft rev) R2.02.01 or later.

\*1: From the table below, select the output to execute the verification function.

Selection		Analog output	Totalizer	Pulse output	Frequency output
Display	HART				
Zero	Zero	0% output	Input 0 (Output fixed)	0 pps	0% output
Measured value	Measured value	Output of calculated value (Undefined)	Totalization of calculated value (Undefined)	Output of calculated value (Undefined)	Output of calculated value (Undefined)
Hold	Hold	Fixes the last valid value before the diagnosis starts.	Totalizes the last valid value before the diagnosis starts.	Fixes the last valid value before the diagnosis starts.	Fixes the last valid value before the diagnosis starts.

\*2: From the table below, select the fluid status required to execute the verification function.

Selection		Description
Display	HART	
No flow	No flow	Executes the verification function with the fluid not flowing.
Flow	Flow	Executes the verification function with the fluid flowing.



\*3: From the table below, select whether or not to execute the verification function.

Selection		Description
Display	HART	
Not execute	Not execute	Does not execute the verification function.
Execute	Execute	Executes the verification function.

\*4: From the table below, select the execution result of the verification function.

Selection		Description
Display	HART	
Factory	Factory	Displays the result obtained upon shipment from the manufacturing factory.
Previous	Previous	Displays the previous result.
Present	Present	Displays the result at this time.

\*5: From the table below, select the target for diagnosis.

Selection		Description
Display	HART	
Magnetic circuit	Magnetic	Magnetic circuit diagnosis
Excite circuit	Excitation	Excitation circuit diagnosis
Calc circuit	Calculation	Calculation circuit diagnosis
Device status	Device status	Device alarm diagnosis
Connect status	Conn status	Wiring misconnection check

In the default state, all of the diagnosis results are reflected in the final results of the verification. Even if an item is set on VF target select so as not to reflect the diagnosis results to the final results of the verification, execution time for the verification does not change because the diagnosis itself is executed. In addition, the diagnosis results selected to "0" with VF target select are displayed as "Skip".  
 Note that verification itself cannot be executed if all diagnoses are unchecked on VF target select (0x0000).

\*6: From the table below, select the result.

Parameter		Description
Display	HART	
Failed/Passed	VF check result	Execution result <sup>*7</sup>
VF operate time	VF operation time	The time at the start of verification execution (displays the device operation time at that time)
Magnetic circuit	Magnetic circuit result	Magnetic circuit diagnosis result <sup>*7</sup>
Excite circuit	Excitation circuit result	Excitation circuit diagnosis result <sup>*7</sup>
Calc circuit	Calculation circuit result	Calculation circuit diagnosis result <sup>*7</sup>
Device status	VF device status result	Device alarm diagnosis result <sup>*7</sup>
Connect status	Connection status result	Wiring misconnection check result <sup>*7</sup>

\*7: From the table below, select the result of the verification function.

Result		Description
Display	HART	
Passed	Passed	There are no problems concerning the diagnosis result.
Failed	Failed	There is a problem concerning the diagnosis result.
Canceled	Canceled	Cancel the diagnosis.
No data	No Data	No diagnosis result data (The verification function is not used.)
Unknown	Unknown	Cannot perform a diagnosis.
Skip	Skip	Out of verification target

---

## IMPORTANT

- Before using the verification function, be sure to disconnect this product from the control loop.
  - When the electrode insulation deterioration diagnosis function is used, the analog output and pulse output are not output correctly.
  - Note that parameters cannot be changed while the verification function is executed.
- 

## NOTE

- Be sure to use the verification function when the sensor is in the full pipe state. If the sensor is in the empty pipe state, the function to detect adhesion may not run normally.
  - When using the verification function, correctly specify the fluid status with the parameter.
  - If there is a problem with the verification result, refer to the Maintenance Manual.
-

## 4.11.7 Electrode Insulation Deterioration Diagnosis

This function is only available for AXG, not for AXW.

The electrode insulation deterioration diagnosis function diagnoses a deterioration of insulation with a resistance value of the electrode and displays a warning if deterioration of insulation is detected. It takes approximately 5 minutes to complete this diagnosis.

For details about the alarm and warning, refer to Subsection 4.8.1.

This setting can be configured with the following parameters.

### Menu path

<b>Display</b>	Device setup ► Diag/Service ► Diagnosis ► (see below)
<b>HART</b>	Diagnostic root menu ► Diagnosis ► (see below)

Parameter		Description
Display	HART	
Diagnostic execute	Diagnostic Exe	Specifies the execution of the electrode insulation deterioration diagnostic function.*1
Diagnostic output	Diagnostic output	Specifies the output to execute the electrode insulation deterioration diagnostic function.*2

\*1: From the table below, select the use of the electrode insulation deterioration diagnostic function.

Selection		Description
Display	HART	
Electrode insul exe	Electronics insulation execute	Starts the electrode insulation deterioration diagnosis function.

\*2: From the table below, select the output while the electrode insulation deterioration diagnostic function is executed.

Selection		Analog output	Totalizer	Pulse output	Frequency output
Display	HART				
Zero	Zero	0% output	Input 0 (Output fixed)	0 pps	0% output
Measured value	Measured value	Output of calculated value (Undefined)	Totalization of calculated value (Undefined)	Output of calculated value (Undefined)	Output of calculated value (Undefined)
Hold	Hold	Fixes the last valid value before the diagnosis starts.	Totalizes the last valid value before the diagnosis starts.	Fixes the last valid value before the diagnosis starts.	Fixes the last valid value before the diagnosis starts.

### IMPORTANT

- Before using the electrode insulation deterioration diagnosis function, be sure to disconnect this product from the control loop.
- When the electrode insulation deterioration diagnosis function is used, the analog output and pulse output are not output correctly.

### NOTE

Be sure to use the electrode insulation deterioration diagnostic function when the sensor is in the full pipe state. If the sensor is in the empty pipe state, the electrode insulation deterioration diagnosis function may not run normally.

### 4.11.8 Flow Noise Diagnosis

This function is only available for AXG, not for AXW.

This function measures a flow noise detected in the sensor, and displays a warning if it exceeds the specified value.

The flow noise diagnosis is shown on the display in four levels: level 1 to level 4. A value to judge each level can be specified individually. If an output exceeds the level 3 or level 4 value, a warning message is displayed.

For details about the alarm and warning, refer to Subsection 4.8.1.

For details about the flow noise span and damping time constant, refer to Subsections 4.1.5 and 4.1.6.

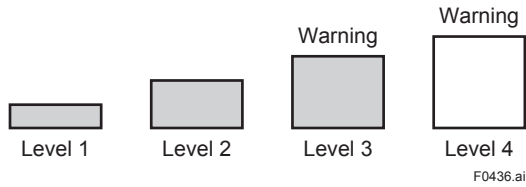

This setting can be configured with the following parameters.

**Menu path**

<b>Display</b>	Device setup ▶ Diag/Service ▶ Diagnosis ▶ Flow noise ▶ (see below)
<b>HART</b>	Diagnostic root menu ▶ Diagnosis ▶ Flow noise ▶ (see below)

Parameter		Description
Display	HART	
Function	Flow noise function	Specifies the use of the flow noise diagnosis function.*1
Threshold level 1	Flow noise level 1	Specifies the value to judge level 1.
Threshold level 2	Flow noise level 2	Specifies the value to judge level 2.
Threshold level 3	Flow noise level 3	Specifies the value to judge level 3.
Threshold level 4	Flow noise level 4	Specifies the value to judge level 4.
Result ▶ Value	Result ▶ Flow noise	Displays the flow noise value.
Result ▶ Status	Result ▶ Flow noise status	Displays the flow noise level.

\*1: From the table below, select the use of the flow noise function.

Selection		Description
Display	HART	
Disable	Disable	Does not use the flow noise diagnosis function.
Enable	Enable	Uses the flow noise diagnosis function.

**NOTE**

If the flow noise diagnosis function is set to “Disable”, the flow noise value and level are cleared.

### 4.11.9 Low Conductivity Diagnosis

This function is only available for AXG, not for AXW.

The low conductivity diagnosis function calculates conductivity from the resistance value and size of the electrode and displays a warning if the conductivity falls below the specified value.

For details about the alarm and warning, refer to Subsection 4.8.1.

This setting can be configured with the following parameters.

**Menu path**

<b>Display</b>	Device setup ▶ Diag/Service ▶ Diagnosis ▶ Conductivity ▶ (see below)
<b>HART</b>	Diagnostic root menu ▶ Diagnosis ▶ Conductivity ▶ (see below)

Parameter		Description
Display	HART	
Function	Low conductivity function	Specifies the use of the low conductivity diagnosis function.*1
Result ▶ Value	Result ▶ Conductivity value	Displays the calculated conductivity.
Low limit	Conductivity low limit	Specifies the value used to judge the low conductivity.

**Menu path**

<b>Display</b>	Device setup ▶ Detailed setup ▶ Device info ▶ Order info ▶ (see below)
<b>HART</b>	Device root menu ▶ Detailed setup ▶ Device information ▶ Order information ▶ (see below)

Parameter		Description
Display	HART	
Electrode size	Electrode size	Displays the electrode size.

\*1: From the table below, select the use of the low conductivity diagnosis function.

Selection		Description
Display	HART	
Disable	Disable	Does not use the low conductivity diagnosis function.
Enable	Enable	Uses the low conductivity diagnosis function.

**NOTE**

The electrode size is specified upon shipment from the manufacturing factory. When any parameters related to the order information about the product are changed, the order information upon shipment from the manufacturing factory cannot be referred to. To store the order information defined upon shipment from the manufacturing factory, it is recommended to refer to Section 4.13 to make a backup.

**NOTE**

Before using the low conductivity diagnosis function, always make sure that the sensor is in the full pipe state. If the sensor is in the empty pipe state or the transmitter is connected with AM012 (calibrator), the function to diagnose conductivity may not run normally.

**NOTE**

If this function is set to “Disable”, the low conductivity value is cleared.

### 4.11.10 Coil Insulation Diagnosis

Coil Insulation Diagnosis is the function to display a warning when the insulation is deteriorated by diagnosing the current value of the exciting current.  
 For details about the alarm and warning, refer to Subsection 4.8.1.  
 This setting can be configured with the following parameters.

**Menu path**

<b>Display</b>	Device setup ► Diag/Service ► Diagnosis ► (see below)
<b>HART</b>	Diagnostic root menu ► Diagnosis ► (see below)

Parameter		Description
Display	HART	
IEX compare	IEX compare	Displays the current value of Exciting current to judge coil insulation.
Coil insul threshold	Coil insulation threshold	Sets the value to judge coil insulation.

### 4.11.11 Other Setting

In addition, the maximum voltage values of the flow rate signal and coil resistance value are displayed as diagnostic information.  
 This information can be viewed with the following parameters.

**Menu path**

<b>Display</b>	Device setup ► Diag/Service ► Diagnosis ► (see below)
<b>HART</b>	Diagnostic root menu ► Diagnosis ► (see below)

Parameter		Description
Display	HART	
V peak hold	V peak hold value	Displays the maximum voltage of the flow signal. (Only available for AXG, not for AXW)
IEX resistance	IEX coil resistance	Displays the coil resistance value.

## 4.12 Test Mode

### 4.12.1 Test Mode Setting

If the test mode is executed, a process value or the value to be output from a connection terminal can be arbitrarily set, and a response from the device can be tested.

A warning is displayed to indicate that the test mode is in use while this test mode is used.

This setting can be configured with the following parameters.

#### Menu path

<b>Display</b>	Device setup ► Diag/Service ► Test ► (see below)
<b>HART</b>	Maintenance root menu ► Test ► (see below)

Parameter		Description
Display	HART	
Input test ► Test mode	Test mode	Specifies the use of the test mode (input).
Output test ► Test mode		Specifies the use of the test mode (output).

From the table below, select the input/output and process value to test.

Selection		Description
Display	HART	
Velocity test	Velocity test on	Starts testing the flow velocity.
Volume test	Volume flow test on	Starts testing the volumetric flow rate.
Mass test	Mass flow test on	Starts testing the mass flow rate.
Calorie test	Calorific value test on	Starts testing the calorie. (Only available for AXG, not for AXW)
AI test	AI test on	Starts testing the analog input. (Only available for AXG, not for AXW)
SI3 test	SI3 test on	Starts testing status input.
AO1 test	AO1 test on	Starts testing analog output 1.
PO1 test	Pulse1 test on	Starts testing pulse output/frequency output 1.
SO1 test	SO1 test on	Starts testing status output 1.
AO2 test	AO2 test on	Starts testing analog output 2. (Only available for AXG, not for AXW)
PO2 test	Pulse2 test on	Starts testing pulse output/frequency output 2.
SO2 test	SO2 test on	Starts testing status output 2.
SO3 test	SO3 test on	Starts testing status output 3.

#### Example: To select an output test item on the display

AO1 test ► SHIFT key ► AO1 test

(Test item can be selected by pushing the SHIFT key)

A test mode value is transmitted in the order of the flow velocity, volumetric flow rate, mass flow rate, and calorie. For example, if the volumetric flow rate is set as a test value, the mass flow rate and calorie can be obtained from the test value. In this case, the test value of the flow velocity is executed with the normal measurement value.

### NOTE

To specify each terminal output, refer to Subsection 4.3.1. If the specified output is different from the test starting output, the test mode cannot be used.

For example, if the pulse/status output is set as a frequency output to start the status output test, the test cannot be started.

## 4.12.2 Test Value Setting

It is necessary to set test values for the input and output and process value to test. This setting can be configured with the following parameters. However, the unit of the process value to test is the same as the unit specified in Subsection 4.1.4. If the unit is changed, the process value is also changed to match to the changed unit.

### Input test

**Menu path**

<b>Display</b>	Device setup ► Diag/Service ► Test ► Input test ► (see below)
<b>HART</b>	Maintenance root menu ► Test ► Input test ► (see below)

Parameter		Description
Display	HART	
Velocity	Velocity	Specifies the flow velocity.
Volume	Volume flow	Specifies the volumetric flow rate.
Mass	Mass flow	Specifies the mass flow rate.
Calorie	Calorific value	Specifies the calorie. (Only available for AXG, not for AXW)
AI	AI	Specifies to the current value of analog input. (Only available for AXG, not for AXW)
SI3	SI3	Specifies the state of status input.

### Output test

**Menu path**

<b>Display</b>	Device setup ► Diag/Service ► Test ► Output test ► (see below)
<b>HART</b>	Maintenance root menu ► Test ► Output test ► (see below)

Parameter		Description
Display	HART	
AO1	AO1	Specifies to the current value of analog output 1.
PO1	Pulse1	Specifies the frequency of pulse output/frequency output 1.
SO1	SO1	Specifies the state of status output 1.
AO2	AO2	Specifies to the current value of analog output 2. (Only available for AXG, not for AXW)
PO2	Pulse2	Specifies the frequency of pulse output/frequency output 2.
SO2	SO2	Specifies the state of status output 2.
SO3	SO3	Specifies the state of status output 3.



### 4.12.3 Test 2 Mode

This function is available when Main soft rev (Main board revision/Main soft rev) is R2.02.01 or later and Ind soft rev (Indicator board revision/Ind soft rev) is R2.02.01 or later.

The test 2 mode is the function to collectively test a process value, analog output, totalized value, and pulse.

The test value can be set in the range between -10.0% and 110.0%.

Input test values (%) are tested with a scale value in response to the span of each process value.

#### ■ Test 2 mode setting

Selects whether to enable test 2 mode.

**Menu path**

<b>Display</b>	Device setup ► Diag/Service ► Test ► Test 2 mode
<b>HART</b>	Maintenance root menu ► Test ► Test 2 mode

Selection	
Display	HART
Normal	Normal
Test	Test

#### ■ Test 2 mode value setting

Test 2 mode value is set with the percentage (%) for the span.

**Menu path**

<b>Display</b>	Device setup ► Diag/Service ► Test ► Test 2 value
<b>HART</b>	Maintenance root menu ► Test ► Test 2 output value

### 4.12.4 Test Mode Auto Reset

When a specific time lapses with no parameters changed after the test mode is enabled, the test mode will be reset automatically. When any test mode parameter is changed, the test mode release time is extended.

The time to automatically reset the test mode can be configured with the following parameters.

**Menu path**

<b>Display</b>	Device setup ► Diag/Service ► Test ► Release time
<b>HART</b>	Maintenance root menu ► Test ► Release time

From the table below, select the test mode auto release time.

Selection		Description
Display	HART	
10 min	10 min	Specifies the release time to 10 min.
30 min	30 min	Specifies the release time to 30 min.
1 h	1 h	Specifies the release time to 1 hr.
3 h	3 h	Specifies the release time to 3 hrs.
12 h	12 h	Specifies the release time to 12 hrs.

# 4.13 Event Management Function

## 4.13.1 Backup Function

The backup function can back up parameter settings in the display's built-in memory (display board) or microSD card (with the optional code MC selected). If the backup data is restored, the parameter settings can be duplicated to another device. The display's built-in memory can store the data for three backups and the microSD card can store as much data as the capacity allows. There are three backup methods available: backup from the main board of the product to the memory on the display board, backup from the main board of the product to the microSD card, and backup from the memory on the display board to the microSD card. The file name, backup name, and date can be specified using the backup function.

The data backed up to the microSD card is stored in the "YOKOGAWA" folder as a ".PAR" file.

This setting can be configured with the following parameters.

For details about the backup parameters, refer to Subsection 4.13.3.

**Menu path**

<b>Display</b>	Device setup ► Diag/Service ► Param bkup/restore ► (see below)
<b>HART</b>	Maintenance root menu ► Param bkup/restore ► (see below)

Parameter		Description
Display	HART	
F backup name	Factory backup name	Displays the backup name defined upon shipment from the manufacturing factory.
F backup date	Factory backup date	Displays the backup date upon shipment from the manufacturing factory.
SD backup name	SD backup name	Specifies the name of the file to be backed up to the microSD card.
Backup name 1	Backup name 1	Specifies backup name 1. Up to 16 characters
Backup date 1	Backup date 1	Specifies date 1.
Backup name 2	Backup name 2	Specifies backup name 2. Up to 16 characters
Backup date 2	Backup date 2	Specifies date 2.
Backup name 3	Backup name 3	Specifies backup name 3. Up to 16 characters
Backup date 3	Backup date 3	Specifies date 3.
Backup execute	Backup Exe	Specifies the use of the backup function.*1
Backup result*	—	Displays the backup result.*2 Displays results in the method for HART communication.

\*: Available for Main soft rev (Main board revision/Main soft rev) R2.02.01 or later and Ind soft rev (Indicator board revision/Ind soft rev) R2.02.01 or later.

### NOTE

When backup execute is completed, the setting value for backup execute returns to "Not execute". The execution results can be confirmed with the parameter of the display, "Backup result".

\*1: From the table below, select how the backup function is to be used.

Selection		Description
Display	HART	
Not execute	Not Execute	Does not back up data.
Store main to 1	Store Main to 1	Backs up parameter settings from the main board to memory 1 in the display's built-in memory.

Selection		Description
Display	HART	
Store main to 2	Store Main to 2	Backs up parameter settings from the main board to memory 2 in the display's built-in memory.
Store main to 3	Store Main to 3	Backs up parameter settings from the main board to memory 3 in the display's built-in memory.
Store main to SD	Store Main to SD	Backs up parameter settings from the main board to the microSD card.
Store EEP1 to SD	Store EEP1 to SD	Backs up parameter settings from memory 1 in the display's built-in memory to the microSD card.
Store EEP2 to SD	Store EEP2 to SD	Backs up parameter settings from memory 2 in the display's built-in memory to the microSD card.
Store EEP3 to SD	Store EEP3 to SD	Backs up parameter settings from memory 3 in the display's built-in memory to the microSD card.

\*2: The result of the backup function is displayed as shown below.

Selection		Description
Display	HART	
Unexecuted	Unexecuted	Backup not executed.
Success	Success	Backup successful.
Failure	Failure	Backup failed.
Running	Running	Parameter backup running.

The table below shows alarms whose parameters can be backed up when an alarm occurs.

✓: Executable when an alarm occurs.  
 —: Not executable when an alarm occurs.

Display	Alarm name		Backup
		HART	
010:Main CPU FAIL	10	Main board CPU failure	—
011:Rev calc FAIL	11	Reverse calculation failure	—
012:Main EEP FAIL	12	Main board EEPROM failure	—
013:Main EEP dfit	13	Main board EEPROM default	—
014:Snsr bd FAIL	14	Sensor board failure	✓
015:Snsr comm ERR	15	Sensor communication error	✓
016:AD 1 FAIL[Sig]	16	A/D1 failure[Signal]	✓
017:AD 2 FAIL[Excit]	17	A/D2 failure[Exciter]	✓
018:Coil open	18	Coil open	✓
019:Coil short	19	Coil short	✓
020:Exciter FAIL	20	Exciter failure	✓
021:PWM 1 stop	21	PWM1 stop	—
022:PWM 2 stop	22	PWM2 stop	—
023:Opt bd mismatch	23	Option board mismatch	—
024:Opt bd EEP FAIL	24	Option board EEPROM failure	—
025:Opt bd A/D FAIL	25	Option board A/D failure	—
026:Opt bd SPI FAIL	26	Option board SPI failure	—
027:Restore FAIL	27	Parameter restore incomplete	✓
028:Ind bd FAIL	28	Indicator board failure	—
029:Ind bd EEP FAIL	29	Indicator board EEPROM failure	—
030:LCD drv FAIL	30	LCD driver failure	—
031:Ind bd mismatch	31	Indicator board mismatch	—
032:Ind comm ERR	32	Indicator communication error	—
033:microSD FAIL	33	microSD failure	—
050:Signal overflow	50	Signal overflow	✓
051:Empty detect	51	Empty pipe detection	✓
052:H/L HH/LL alm	52	H/L or HH/LL alarm	✓
053:Adh over lv 4	53	Adhesion over level 4	✓
060:Span cfg ERR	60	Span configuration error	—

Display	Alarm name		Backup
		HART	
061:PV F cfg ERR	61	PV flow select configuration error	—
062:AO 1 4-20 lmt	62	Analog output 1 4-20mA limit error	—
063:AO 2 4-20 lmt	63	Analog output 2 4-20 mA limit error	—
064:AO 1 mlt rng	64	Analog output 1 multi range error	—
065:H/L cfg ERR	65	H/L HH/LL configuration error	—
066:Density cfg ERR	66	Density configuration error	—
067:Pls 1 cfg ERR	67	Pulse output 1 configuration error	—
068:Pls 2 cfg ERR	68	Pulse output 2 configuration error	—
069:Nomi size cfg	69	Nominal size configuration error	—
070:Adh cfg ERR	70	Adhesion configuration error	—
071:FLN cfg ERR	71	Flow noise configuration error	—
072:Log not start	72	Data logging not started	—
080:AO 1 saturate	80	Analog output 1 saturated	✓
081:AO 2 saturate	81	Analog output 2 saturated	✓
082:Pls 1 saturate	82	Pulse output 1 saturated	✓
083:Pls 2 saturate	82	Pulse output 2 saturated	✓
084:AI saturate	84	Analog input saturated	✓
085:Cable miscon	85	Cable misconnect	✓
086:Coil insulation	86	Coil insulation warning	✓
131:Trans mismatch	131	Transmitter type mismatch	—
087:Adhesion lv 3	87	Adhesion over level 3	✓
088:LC warn	88	Low conductivity warning	✓
089:Insu detect	89	Insulation detection	✓
090:FLN over lv 3	90	Flow noise over level 3	✓
091:FLN over lv 4	91	Flow noise over level 4	✓
092:AZ warn	92	Autozero warning	✓
093:Verif warn	93	Verification warning	✓
094:Fact noise warn	94	Factory noise warning	✓
095:Simulate active	95	Simulation active	✓
096:AO 1 fix	96	Analog output 1 fixed	✓
097:AO 2 fix	97	Analog output 2 fixed	✓
098:Pls 1 fix	98	Pulse output 1 fixed	✓
099:Pls 2 fix	99	Pulse output 2 fixed	✓
100:AI fix	100	Analog input fixed	✓
101:Param restore run	101	Parameter restore running	—
102:Disp over	102	Display over warning	—
103:SD size warn	103	microSD card size warning	—
104:Bkup incmplt	104	Parameter backup incomplete	✓
105:SD mismatch	105	microSD card mismatch	—
106:SD removal ERR	106	microSD card removal procedure error	—
120:Watchdog	120	Watchdog	✓
121:Power off	121	Power off	✓
122:Inst power FAIL	122	Instant power failure	✓
123:Param bkup run	123	Parameter backup running	—
124>Data log run	124	Data logging running	✓
130:DevID not enter	130	Device ID not entered	✓

## IMPORTANT

- Note that parameters cannot be changed when the backup function is executed. It takes approximately 20 seconds to complete backup processing.
- Take care not to duplicate the file name when backing up data to the microSD card.
- Note that if the microSD card runs out of free space, the subsequent data will not be stored.

**NOTE**

The backup name and date do not affect the backup function. Use this as the memo column when performing the backup function.

### 4.13.2 Restore/Duplicate Parameter

If the restore function is used, it becomes possible to restore parameter settings, which are backed up in the display's built-in memory or microSD card (optional code MC), to the product. In addition, it is possible to return parameters to default values defined when shipped from the factory and to duplicate the backed-up parameters to other device based on the same specifications.

**IMPORTANT**

- For the remote type, it is necessary to set the device information of the remote sensor to the parameters of the remote transmitter.
- Before using the restore function, be sure to remove this product from piping line or stop the line.
- After executing the restore function, check that backup data is set for the target parameter.
- When using the restore function to duplicate the backed-up parameters to other device, be sure to re-set the values before duplication to the parameter "Low MF", "High MF", "Trans serial No" and "Sensor serial No" after duplicating. If the parameter "Low MF" and "High MF" are not re-set, the error will occur in the flow rate measurement.

The restore method can be selected from the following four types.

Duplicate Data	Restores the target parameter (excluding the factory adjusted value of the transmitter) from the product for which the parameter is backed up. Restore is also executable for other products.
Restore Data	Restores the target parameter (including the factory adjusted value of the transmitter) from the product for which the parameter is backed up. Restore is not executable for other products.
Compulsion Data	Restores the target parameter (specified at factory shipping) from the product for which the parameter is backed up. Restore is also executable for other products.
Restore factory	Restores all the parameters (specified upon shipment from the manufacturing factory).

When using the restore function, always make sure that the backed-up device information matches the device information to be restored.

The table below shows the consistency of the device information.

✓: Items to be Matched.

Device Information	Duplicate Data	Restore Data	Compulsion Data
Option Board ID	✓	✓	-
Transmitter Serial No	-	✓	-
Sensor Serial No	-	✓	-
Main Board Software Rev.	✓	✓	-
Sensor Board Software Rev.	✓	✓	-
Display Board Software Rev.	✓	✓	-
Model (Note)	✓	✓	-
Communication and I/O Code	✓	✓	-

**NOTE**

Data can only be duplicated or restored between products of the same model.

This setting can be configured with the following parameters.  
 For details about the restorable parameters, refer to Subsection 4.13.3.

**Menu path**

<b>Display</b>	Device setup ▶ Diag/Service ▶ Param bkup/restore ▶ (see below)
<b>HART</b>	Maintenance root menu ▶ Param bkup/restore ▶ (see below)

Parameter		Description
Display	HART	
Restore execute	Restore Exe	Specifies the execution of the restore function.*1
Restore result	—	Displays the restore result.*2

**NOTE**

When restore execute is completed, the setting value for restore execute returns to “Not execute”. The execution results can be confirmed with the parameter of the display, “Restore result”.

\*1: From the table below, select the execution of the restore function.

Selection		Description
Display	HART	
Not execute	Not Execute	Does not restore data.
Duplicate data 1	Duplicate Data1	Restores the parameter (Duplicate Data) setting from memory 1 on the display board to the main board of the product.
Duplicate data 2	Duplicate Data2	Restores the parameter (Duplicate Data) setting from memory 2 on the display board to the main board of the product.
Duplicate data 3	Duplicate Data3	Restores the parameter (Duplicate Data) setting from memory 3 on the display board to the main board of the product.
Duplicate SD	Duplicate SD	Restores the parameter (Duplicate Data) setting from the microSD card to the main board of the product.
Restore data 1	Restore Data1	Restores the parameter (Restore Data) setting from memory 1 on the display board to the main board of the product.
Restore data 2	Restore Data2	Restores the parameter (Restore Data) setting from memory 2 on the display board to the main board of the product.
Restore data 3	Restore Data3	Restores the parameter (Restore Data) setting from memory 3 on the display board to the main board of the product.
Restore SD	Restore SD	Restores the parameter (Restore Data) setting from the microSD card to the main board of the product.
Compulsion data 1	Compulsion Data1	Restores the parameter (Compulsion Data) setting from memory 1 on the display board to the main board of the product.
Compulsion data 2	Compulsion Data2	Restores the parameter (Compulsion Data) setting from memory 2 on the display board to the main board of the product.
Compulsion data 3	Compulsion Data3	Restores the parameter (Compulsion Data) setting from memory 3 on the display board to the main board of the product.
Compulsion SD	Compulsion SD	Restores the parameter (Compulsion Data) setting from the microSD card to the main board of the product.
Restore factory	Restore Factory	Restores to the status that is set upon shipment from the manufacturing factory.

\*2: The result of the restore function is displayed as shown below.

Selection		Description
Display	HART	
Unexecuted	Unexecuted	Have not restored
Success	Success	Succeeded in restoration.
Failure	Failure	Failed in restoration.
Running	Running	Restore running

The table below shows alarms whose parameters can be restored or duplicated when an alarm occurs.

✓: Executable when an alarm occurs.  
 —: Not executable when alarm occurs.

Display	Alarm name		Restore
		HART	
010:Main CPU FAIL	10	Main board CPU failure	—
011:Rev calc FAIL	11	Reverse calculation failure	—
012:Main EEP FAIL	12	Main board EEPROM failure	—
013:Main EEP dflt	13	Main board EEPROM default	—
014:Snsr bd FAIL	14	Sensor board failure	✓
015:Snsr comm ERR	15	Sensor communication error	✓
016:AD 1 FAIL[Sig]	16	A/D1 failure[Signal]	✓
017:AD 2 FAIL[Excit]	17	A/D2 failure[Exciter]	✓
018:Coil open	18	Coil open	✓
019:Coil short	19	Coil short	✓
020:Exciter FAIL	20	Exciter failure	✓
021:PWM 1 stop	21	PWM1 stop	—
022:PWM 2 stop	22	PWM2 stop	—
023:Opt bd mismatch	23	Option board mismatch	—
024:Opt bd EEP FAIL	24	Option board EEPROM failure	—
025:Opt bd A/D FAIL	25	Option board A/D failure	—
026:Opt bd SPI FAIL	26	Option board SPI failure	—
027:Restore FAIL	27	Parameter restore incomplete	✓
028:Ind bd FAIL	28	Indicator board failure	—
029:Ind bd EEP FAIL	29	Indicator board EEPROM failure	—
030:LCD drv FAIL	30	LCD driver failure	—
031:Ind bd mismatch	31	Indicator board mismatch	—
032:Ind comm ERR	32	Indicator communication error	—
033:microSD FAIL	33	microSD failure	—
050:Signal overflow	50	Signal overflow	✓
051:Empty detect	51	Empty pipe detection	✓
052:H/L HH/LL alm	52	H/L or HH/LL alarm	✓
053:Adh over lv 4	53	Adhesion over level 4	✓
060:Span cfg ERR	60	Span configuration error	—
061:PV F cfg ERR	61	PV flow select configuration error	—
062:AO 1 4-20 lmt	62	Analog output 1 4-20mA limit error	—
063:AO 2 4-20 lmt	63	Analog output 2 4-20 mA limit error	—
064:AO 1 mlt rng	64	Analog output 1 multi range error	—
065:H/L cfg ERR	65	H/L HH/LL configuration error	—
066:Density cfg ERR	66	Density configuration error	—
067:Pls 1 cfg ERR	67	Pulse output 1 configuration error	—
068:Pls 2 cfg ERR	68	Pulse output 2 configuration error	—
069:Nomi size cfg	69	Nominal size configuration error	—
070:Adh cfg ERR	70	Adhesion configuration error	—
071:FLN cfg ERR	71	Flow noise configuration error	—
072:Log not start	72	Data logging not started	—
080:AO 1 saturate	80	Analog output 1 saturated	✓
081:AO 2 saturate	81	Analog output 2 saturated	✓

Alarm name		Restore	
Display	HART		
082:Pls 1 saturate	82	Pulse output 1 saturated	✓
083:Pls 2 saturate	83	Pulse output 2 saturated	✓
084:AI saturate	84	Analog input saturated	✓
085:Cable miscon	85	Cable misconnect	✓
086:Coil insulation	86	Coil insulation warning	✓
131:Trans mismatch	131	Transmitter type mismatch	—
087:Adhesion lv 3	87	Adhesion over level 3	✓
088:LC warn	88	Low conductivity warning	✓
089:Insu detect	89	Insulation detection	✓
090:FLN over lv 3	90	Flow noise over level 3	✓
091:FLN over lv 4	91	Flow noise over level 4	✓
092:AZ warn	92	Autozero warning	✓
093:Verif warn	93	Verification warning	✓
094:Fact noise warn	94	Factory noise warning	✓
095:Simulate active	95	Simulation active	✓
096:AO 1 fix	96	Analog output 1 fixed	✓
097:AO 2 fix	97	Analog output 2 fixed	✓
098:Pls 1 fix	98	Pulse output 1 fixed	✓
099:Pls 2 fix	99	Pulse output 2 fixed	✓
100:AI fix	100	Analog input fixed	✓
101:Param restore run	101	Parameter restore running	—
102:Disp over	102	Display over warning	—
103:SD size warn	103	microSD card size warning	—
104:Bkup incmplt	104	Parameter backup incomplete	✓
105:SD mismatch	105	microSD card mismatch	—
106:SD removal ERR	106	microSD card removal procedure error	—
120:Watchdog	120	Watchdog	✓
121:Power off	121	Power off	✓
122:Inst power FAIL	122	Instant power failure	✓
123:Param bkup run	123	Parameter backup running	—
124>Data log run	124	Data logging running	✓
130:DevID not enter	130	Device ID not entered	✓

## IMPORTANT

When using the restore function, be sure to prepare a backup file in the built-in memory or the microSD card. Note that the restore function is not executable if a backup file is not provided.



### 4.13.3 Backup and Restore Parameters

The list below shows the parameters that can be backed up or restored. However, the date to be restored with “Compulsion Data” is the value(s) specified by the customer upon shipment from the manufacturing factory. (Default value when not designated)

Parameter		Restore or Duplicate			
Display	HART	Duplicate Data	Restore Data	Compulsion Data	Restore factory
Damp AO/F	Velocity damping AO/frequency	✓	✓	—	✓
Damp pls/ttl	Velocity damping pulse/total	✓	✓	—	✓
Damp AO/F	Volume flow damping AO/frequency	✓	✓	—	✓
Damp pls/ttl	Volume flow damping pulse/total	✓	✓	—	✓
Damp AO/F	Mass flow damping AO/frequency	✓	✓	—	✓
Damp pls/ttl	Mass flow damping pulse/total	✓	✓	—	✓
Damp AO/F	Calorific value damping AO/frequency	✓	✓	—	✓
Damp pls/ttl	Calorific value damping pulse/total	✓	✓	—	✓
Low MF	Low MF	✓	✓	✓	✓
High MF	High MF	✓	✓	✓	✓
Flow sensor sel	Flow sensor select	✓	✓	—	✓
Nominal size unit	Nominal size unit	✓	✓	✓	✓
Nominal size	Nominal size	✓	✓	✓	✓
PV flow select	PV flow select	✓	✓	✓	✓
Unit	Velocity unit	—	—	✓	✓
Unit	Volume flow unit	—	—	✓	✓
Unit	Mass flow unit	—	—	✓	✓
Time unit	Time unit	—	—	✓	✓
Span	Velocity span	✓	✓	✓	✓
Span	Volume flow span	✓	✓	✓	✓
Span	Mass flow span	✓	✓	✓	✓
Span	Calorific flow span	✓	✓	—	✓
Zero value	Zero value	✓	✓	—	✓
Conv factor	Total1 conv factor	—	—	✓	✓
Low cut	Total1 low cut	✓	✓	✓	✓
Failure opts	Total1 fail opts	✓	✓	—	✓
Options	Total1 options	✓	✓	—	✓
Start/Stop	Total1 Start/Stop	✓	✓	—	✓
Reset/Preset	Total1 Reset/Preset	✓	✓	—	✓
Preset value	Total1 preset value	✓	✓	—	✓
Set point	Total1 set point	✓	✓	—	✓
Low cut	Total2 low cut	✓	✓	—	✓
Failure opts	Total2 fail opts	✓	✓	—	✓
Options	Total2 options	✓	✓	—	✓
Start/Stop	Total2 Start/Stop	✓	✓	—	✓
Reset/Preset	Total2 Reset/Preset	✓	✓	—	✓
Preset value	Total2 preset value	✓	✓	—	✓
Set point	Total2 set point	✓	✓	—	✓
Low cut	Total3 low cut	✓	✓	—	✓
Failure opts	Total3 fail opts	✓	✓	—	✓
Options	Total3 options	✓	✓	—	✓
Start/Stop	Total3 Start/Stop	✓	✓	—	✓
Reset/Preset	Total3 Reset/Preset	✓	✓	—	✓
Preset value	Total3 preset value	✓	✓	—	✓
Set point	Total3 set point	✓	✓	—	✓
Output mode	Pulse1 output mode	✓	✓	✓	✓
Active mode	Pulse1 active mode	✓	✓	—	✓

Parameter		Restore or Duplicate			
Display	HART	Duplicate Data	Restore Data	Compulsion Data	Restore factory
Fix width	Pulse1 fix width	✓	✓	—	✓
Rate unit	Pulse1 rate unit	—	—	✓	✓
Rate value	Pulse1 rate value	✓	✓	✓	✓
Low cut	Pulse1 low cut	✓	✓	✓	✓
Alarm out	Pulse1 alarm out	✓	✓	—	✓
Frequency at 0%	Frequency1 at 0%	✓	✓	✓	✓
Frequency at 100%	Frequency1 at 100%	✓	✓	✓	✓
SO1 function	Status output1 function	✓	✓	—	✓
Options	Pulse1 option	✓	✓	—	✓
Active pulse	Pulse2 active pulse	✓	✓	—	✓
Output mode	Pulse2 output mode	✓	✓	—	✓
Pulse select	Pulse2 select	✓	✓	—	✓
Active mode	Pulse2 active mode	✓	✓	—	✓
Fix width	Pulse2 fix width	✓	✓	—	✓
Rate value	Pulse2 rate value	✓	✓	—	✓
Low cut	Pulse2 low cut	✓	✓	—	✓
Alarm out	Pulse2 alarm out	✓	✓	—	✓
Frequency at 0%	Frequency2 at 0%	✓	✓	—	✓
Frequency at 100%	Frequency2 at 100%	✓	✓	—	✓
SO2 function	Status output2 function	✓	✓	—	✓
Options	Pulse2 option	✓	✓	—	✓
Active mode	Status output3 active mode	✓	✓	—	✓
Function	Status output3 function	✓	✓	—	✓
Active mode	Status input3 active mode	✓	✓	—	✓
Function	Status input3 function	✓	✓	—	✓
Forward span 2	Forward span 2	✓	✓	—	✓
Reverse span 1	Reverse span 1	✓	✓	—	✓
Reverse span 2	Reverse span 2	✓	✓	—	✓
Auto range hyst	Auto range hyst	✓	✓	—	✓
Bi direction hyst	Bi direction hyst	✓	✓	—	✓
Low cut	AO1 low cut	✓	✓	—	✓
High limit	AO1 high limit	✓	✓	—	✓
Low limit	AO1 low limit	✓	✓	—	✓
Alarm out	AO1 alarm out	✓	✓	✓	✓
Range mode	AO1 range mode	✓	✓	—	✓
AO2 select	AO2 select	✓	✓	—	✓
Low cut	AO2 low cut	✓	✓	—	✓
High limit	AO2 high limit	✓	✓	—	✓
Low limit	AO2 low limit	✓	✓	—	✓
Alarm out	AO2 alarm out	✓	✓	—	✓
Function	AI function	✓	✓	—	✓
URV	AI URV	✓	✓	—	✓
LRV	AI LRV	✓	✓	—	✓
AO1 trim 4mA	AO1 Trim	✓	✓	—	✓
AO1 trim 20mA		✓	✓	—	✓
AO2 trim 4mA	AO2 Trim	✓	✓	—	✓
AO2 trim 20mA		✓	✓	—	✓
Flow direct	Flow direction	✓	✓	—	✓
Rate limit	Rate limit	✓	✓	—	✓
Dead time	Dead time	✓	✓	—	✓
Noise filter	Noise filter	✓	✓	—	✓
Pulsing flow	Pulsing flow	✓	✓	—	✓

Parameter		Restore or Duplicate			
Display	HART	Duplicate Data	Restore Data	Compulsion Data	Restore factory
Power sync	Power synchronize	✓	✓	✓	✓
Set power freq	Set power frequency	✓	✓	✓	✓
Value select	Density value select	✓	✓	—	✓
Fixed density	Density fixed value	✓	✓	✓	✓
Std density	Standard density	✓	✓	—	✓
Std temperature	Standard temperature	✓	✓	—	✓
Coef A1	Temp coef A1	✓	✓	—	✓
Coef A2	Temp coef A2	✓	✓	—	✓
Specific heat	Specific heat	✓	✓	—	✓
Fixed temperature	Calorific fix temp	✓	✓	—	✓
High alarm	High alarm	✓	✓	—	✓
Low alarm	Low alarm	✓	✓	—	✓
HH alarm	High high alarm	✓	✓	—	✓
LL alarm	Low low alarm	✓	✓	—	✓
H/L alarm hyst	Hi/Lo alarm hysteresis	✓	✓	—	✓
Line 1	Display select1	—	—	✓	✓
Line 2	Display select2	—	—	✓	✓
Line 3	Display select3	—	—	✓	✓
Line 4	Display select4	—	—	✓	✓
Line 5	Display select5	—	—	✓	✓
Line 6	Display select6	—	—	✓	✓
Line 7	Display select7	—	—	✓	✓
Line 8	Display select8	—	—	✓	✓
Format PV	Display format PV	—	—	✓	✓
Line mode	Display line	—	—	✓	✓
Disp install	Display installation	—	—	✓	✓
—	IRSW operation	—	—	✓	✓
Tag No	Tag	—	—	✓	✓
Long tag	Long tag	—	—	✓	✓
Electrode size	Electrode size	✓	✓	—	✓
Model code	Basic model code	✓	✓	—	✓
Suffix config 1	Suffix config 1	✓	✓	—	✓
Suffix config 2	Suffix config 2	✓	✓	—	✓
Option 1	Option 1	✓	✓	—	✓
Option 2	Option 2	✓	✓	—	✓
Option 3	Option 3	✓	✓	—	✓
Option 4	Option 4	✓	✓	—	✓
Model code	Remote sensor basic model code	✓	✓	—	✓
Suffix config 1	Remote sensor suffix config 1	✓	✓	—	✓
Suffix config 2	Remote sensor suffix config 2	✓	✓	—	✓
Option 1	Remote sensor option 1	✓	✓	—	✓
Option 2	Remote sensor option 2	✓	✓	—	✓
Option 3	Remote sensor option 3	✓	✓	—	✓
Option 4	Remote sensor option 4	✓	✓	—	✓
Trans serial No	Transmitter serial No	✓	✓	—	✓
Sensor serial No	Sensor serial No	✓	✓	—	✓
Function	Adhesion function	✓	✓	✓	✓
Threshold level 1	Adhesion level 1	✓	✓	—	✓
Threshold level 2	Adhesion level 2	✓	✓	—	✓
Threshold level 3	Adhesion level 3	✓	✓	—	✓
Threshold level 4	Adhesion level 4	✓	✓	—	✓
Check cycle	Adhesion check cycle	✓	✓	—	✓

Parameter		Restore or Duplicate			
Display	HART	Duplicate Data	Restore Data	Compulsion Data	Restore factory
Function	Flow noise function	✓	✓	—	✓
Threshold level 1	Flow noise level 1	✓	✓	—	✓
Threshold level 2	Flow noise level 2	✓	✓	—	✓
Threshold level 3	Flow noise level 3	✓	✓	—	✓
Threshold level 4	Flow noise level 4	✓	✓	—	✓
Damp	Flow noise damping	✓	✓	—	✓
Span	Flow noise span	✓	✓	✓	✓
Function	Low conductivity function	✓	✓	—	✓
Low limit	Conductivity low limit	✓	✓	—	✓
Coil insul threshold	Coil insulation threshold	✓	✓	—	✓
IEX compare	IEX compare	✓	✓	—	✓
Diagnostic output	Diagnostic output	✓	✓	—	✓
Mode	VF mode	✓	✓	—	✓
VF No	VF No	✓	✓	—	✓
Release time	Release time	✓	✓	—	✓

## 4.13.4 Data Logging Function

When the optional code MC (microSD card) is selected, the data logging function can store up to four process values to the microSD card. To use this function, it is necessary to specify a file name, data storage interval, and ending time.

Stored data is saved in the “YOKOGAWA” folder as a “.TRD” file.

This setting can be configured with the following parameters.

### Menu path

<b>Display</b>	Device setup ▶ Diag/Service ▶ Data log ▶ (see below)
<b>HART</b>	Maintenance root menu ▶ Data logging ▶ (see below)

Parameter		Description
Display	HART	
File name	File name	Specifies the name of the file to be stored.
Interval time	Interval time	Specifies the data storage interval.*1
Start date	Start date	Displays the date to start the data logging function.
Start time	Start time	Displays the time to start the data logging function.
End time	End time	Specifies the time to end the data logging function.*2
Log 1	Log1 select	Specifies process value 1 to be stored.*3
Log 2	Log2 select	Specifies process value 2 to be stored.*3
Log 3	Log3 select	Specifies process value 3 to be stored.*3
Log 4	Log4 select	Specifies process value 4 to be stored.*3
Execute	Logging Exe	Specifies the execution of the data logging function.*4

\*1: From the table below, select the data storage interval.

Selection		Description
Display	HART	
1 s	1 sec	Sets the storage interval to 1 sec.
10 s	10 sec	Sets the storage interval to 10 sec.
30 s	30 sec	Sets the storage interval to 30 sec.
1 min	1 min	Sets the storage interval to 1 min.
5 min	5 min	Sets the storage interval to 5 min.
30 min	30 min	Sets the storage interval to 30 min.
1 h	1 h	Sets the storage interval to 1 hour.

\*2: From the table below, select the ending time of the data logging function.

Selection		Description
Display	HART	
10 min	10 min	Sets the ending time to 10 minutes later.
30 min	30 min	Sets the ending time to 30 minutes later.
1 h	1 h	Sets the ending time to 1 hour later.
3 h	3 h	Sets the ending time to 3 hours later.
12 h	12 h	Sets the ending time to 12 hours later.
24 h	24 h	Sets the ending time to 24 hours (1 day) later.
72 h	72 h	Sets the ending time to 72 hours (3 days) later.
240 h	240 h	Sets the ending time to 240 hours (10 days) later.
720 h*	720 h*	Sets the ending time to 720 hours (30 days) later.
1440 h*	1440 h*	Sets the ending time to 1440 hours (60 days) later.

\*: Available for Main soft rev (Main board revision/Main soft rev) R2.02.01 or later and Ind soft rev (Indicator board revision/Ind soft rev) R2.02.01 or later.

\*3: From the table below, select the process value to be stored.

Selection		Description
Display	HART	
Velocity	Velocity	Stores the flow velocity.
Volume flow	Volume flow	Stores the volumetric flow rate.
Mass flow	Mass flow	Stores the mass flow rate.
Calorie	Calorie	Stores the calorie. (Only available for AXG, not for AXW)
PV	PV	Stores the PV-mapped process value of Subsection 4.1.2.
Flow noise	Flow noise	Stores the flow noise value. (Only available for AXG, not for AXW)
Adhesion	Adhesion	Stores the resistance value of the electrode adhesion detection.
Electrode A	Electrode A	Stores the voltage of electrode A.
Electrode B	Electrode B	Stores the voltage of electrode B.
V peak	V peak	Stores the peak value of the flow rate signal. (Only available for AXG, not for AXW)

\*4: From the table below, select the use of the data logging function.

Selection		Description
Display	HART	
Not execute	Not execute	Does not execute the data logging function.
Execute	Execute	Executes the data logging function.

Setting data is stored on the microSD card at a specified storage interval during a period from the start of the data logging function to the end. The file stored by the data logging function can be opened as a text file.

Example: If the storage interval is set to “1 min”, data is stored as shown below.

2017/01/01 12:00:00	+9.9863E-01	+2.8235E+01	+1.4117E+04	+4.5600E-01
2017/01/01 12:01:00	+9.9909E-01	+2.8248E+01	+1.4124E+04	+3.9717E-01
2017/01/01 12:02:00	+9.9906E-01	+2.8248E+01	+1.4124E+04	+3.1753E-01
2017/01/01 12:03:00	+9.9859E-01	+2.8234E+01	+1.4117E+04	+4.0430E-01
2017/01/01 12:04:00	+9.9870E-01	+2.8237E+01	+1.4118E+04	+3.6609E-01
2017/01/01 12:05:00	+9.9829E-01	+2.8226E+01	+1.4113E+04	+4.1892E-01



Date and time
Process value 1
Process value 2
Process value 3
Process value 4

F0437.ai

The access ongoing to the microSD card can be confirmed by the icon on the display. For example, the icons of “microSD card ready” and “Accessing microSD card” are displayed alternately and repeatedly because the product accesses the microSD card periodically during its data logging.

When the microSD card cannot be accessed to remove, the icon of “Error accessing microSD card” is displayed.

Insert the microSD card again when it is necessary to use this function again. An alarm of “microSD failure” occurs when the microSD card has any problems.

	Ready for microSD card		Accessing microSD card
	Disable to access microSD card		

---

**IMPORTANT**

---

- When using the data logging function, be sure to set the date and time information.
  - Before using the data logging function, make sure that the microSD card is prepared. It takes approximately 1 minute until the product is ready to store data on the microSD card after it has been turned on.
  - Note that the date and time information are reset if this product is turned off.
  - Note that if the microSD card runs out of free space, the subsequent data will not be stored.
-

## 4.14 Parameter Protection

### 4.14.1 Software Write Protection Function

Write protect can be specified by two methods; the hardware write protect switch and software write protect. When the write protect is set using one of these methods, data cannot be written to a parameter. For details about the hardware write protection switch, refer to the Installation Manual.

To enable the software write protection function, it is necessary to specify a “New password” (eight alphanumeric characters, excluding lowercase). By inputting the password in “Enable write”, it becomes possible to disable the write protection only for 10 minutes. The write protection function can be completely disabled by entering eight spaces in “New password” while the protection is disabled temporarily.

The write protection function can be configured with the following parameters.

**Menu path**

<b>Display</b>	Device setup ► Detailed setup ► Protection ► (see below)
<b>HART</b>	Device root menu ► Detailed setup ► Protection ► (see below)

Parameter		Description
Display	HART	
Write protect sts	Write protect	Indicates the use of the write protection function. *1
Enable write	Enable write 10 min	Cancels the write protection function only for 10 minutes.
New password	New password	Specifies a new pass word for the write protection function.



\*1: Display of the use status of the write protection function

Value		Description
Display	HART	
No	No	The write protection function is not in use. (Parameter can be changed)
Yes	Yes	The write protection function is being used. (Parameter cannot be changed)

### NOTE

The usage status of the write protect function can be checked by the icon displayed on the parameter or display.

The following icons are displayed.

Icon	Description
	Write protect Disable (Parameters can be changed)
	Write protect Enable (Parameter cannot be changed)

### NOTE

When the write protection switch on the amplifier board is turned on, no parameters can be changed.

To change a parameter, cancel the write protection function with the pre-specified password and specify a new password.



If the password is forgotten, it is possible to temporarily disable the software write protection function by using the Joker password.

When the write protection function is disabled using the Joker password, "Break" is displayed as the software seal (because the write protection is not disabled with the regular route). To set the software seal back to "Keep", it needs to set the write protection again. When the write protection is temporarily disabled using the formal password, the software seal is set back from "Break" to "Keep".

The use of the Joker password seal can be checked by the following parameter.

**Menu path**

<b>Display</b>	Device setup ▶ Detailed setup ▶ Protection ▶ Soft seal status
<b>HART</b>	Device root menu ▶ Detailed setup ▶ Protection ▶ Software seal

Check the use of the Joker password depending on the following parameters.

Value		Description
Display	HART	
Keep	Keep	Normal
Break	Break	Disable the write protection function using the Joker password.

**NOTE**

If it is necessary to use the Joker password, contact Yokogawa sales office or representative.

### 4.14.2 Display Restriction Function

Access to the service mode is limited.

**Menu path**

<b>Display</b>	Device setup ▶ Detailed setup ▶ Protection ▶ Key code
----------------	---

# 5. Parameter Lists

This chapter shows parameter lists of the display and HART communication.

Each parameter is set as specified at the time of ordering. Since other parameters have default values set, be sure to refer to this chapter when changing them.

## IMPORTANT

If this product is turned off before 30 seconds after setting the parameters, the settings will not be saved correctly. Please keep the product turned on for over 30 seconds after setting the parameters.

## NOTE

To obtain correct flow signals, it is necessary to set the nominal size, flow rate span and meter factor of the flow sensor. The nominal size and meter factor of the flow sensor are set on this product when shipped from the manufacturing factory, and a customer is not required to set them.

If a particular parameters is specified at the time of order, this product is shipped with the parameter specified. If a parameter is not specified at the time of order, that parameter needs to be set by the customer.

## NOTE

The available functions and parameters displayed vary depending on communication and I/O code specified at the time of ordering.

✓: Parameter displayed

Function of terminal	Description	Communication and I/O Code														
		JA	JB	JC	JD	JE	JF	JG	JH	JJ	JK	JP	JQ	JR	JS	JT
		E				J		L								
Analog output 1	Regardless of the code selection, parameters related to analog output 1 are displayed.	✓	✓	✓	✓	✓	✓	✓	✓	✓	✓	✓	✓	✓	✓	✓
Analog output 2	Depending on the code selection, parameters related to analog output 2 may not be displayed. No.7-6 to 7-10, 7-21 to 7-23, 13-11		✓	✓					✓			✓	✓	✓		
Pulse Status output 1	Regardless of the code selection, parameters related to pulse/status output 1 are displayed.	✓	✓	✓	✓	✓	✓	✓	✓	✓	✓	✓	✓	✓	✓	✓
Pulse Status output 2	Depending on the code selection, parameters related to pulse/status output 2 may not be displayed. No.5-12 to 5-24, 13-13 to 13-14		✓		✓	✓	✓	✓		✓			✓		✓	
Status output 3	Depending on the code selection, parameters related to the status output may not be displayed.				✓											
Status input	Depending on the code selection, parameters related to the status input may not be displayed. No.6-3 to 6-5, 13-7			✓		✓	✓	✓			✓					

Function of terminal	Description	Communication and I/O Code														
		JA E	JB	JC	JD	JE J	JF	JG L	JH	JJ	JK	JP	JQ	JR	JS	JT
Analog input	Depending on the code selection, parameters related to the analog input may not be displayed. No.7-11 to 7-17, 7-24 to 7-26, 8-13 to 8-21, 13-6, 13-15								✓	✓	✓					

The parameter list consists of the following items.

<b>No.</b>	Symbol <sup>(G)</sup> = only available for AXG, not for AXW
<b>Parameter Name</b>	Indicates a parameter name.
<b>Data range</b>	Indicates options for select type data. Indicates the setting range and the number of decimal places for numeric-type data. Indicates the limited number of characters for alphanumeric type data. Symbol <sup>(G)</sup> = only available for AXG, not for AXW
<b>R/W</b>	Indicates parameters which can be displayed and set. R: Displayed only, RW: Displayed and specified. However, when changing parameters on the display, a parameter which can be set depends on operation levels. Operator: Possible to set a display language on the display and parameters related to display items. Maintenance: Possible to set parameters allowed to set with the operator level and parameters related to zero adjustment. Specialist: Possible to set all writable parameters.
<b>Default value</b>	Indicates the default value upon shipment from the manufacturing factory.
<b>Unit</b>	Indicates the unit of the data range.
<b>Reference</b>	Reference page of parameter contents.

# 5.1 Display Parameters

These parameters are related to flow and totalizer display.

No.	Parameter Name		Data Range		R/W	Default Value	Unit	Reference
	HART	Display	HART	Display				
1-1	Process variables root menu ▶ Dynamic variables ▶ PV % mge	-	-999.999 to +999.999 Number of decimal places: 3	-	R	-	%	P.41
	Process variables root menu ▶ Device variables ▶ Disp flowrate%	Device setup ▶ Process variables ▶ Flow rate(%)		-999999.9 to +999999.9 Number of decimal places: 1				
1-2	Process variables root menu ▶ Dynamic variables ▶ PV	-	-999999 to +999999 Number of decimal places: 0 to 5	-	R	-	Flow velocity No.3-15 Volumetric flow rate: No.3-16/ No.3-19 Mass flow rate: No.3-17/ No.3-19 Flow noise cm/s	P.41
	Process variables root menu ▶ Device variables ▶ Disp flowrate	Device setup ▶ Process variables ▶ Flow rate		-999999 to +999999 Number of decimal places: 0 to 5				
1-3	Process variables root menu ▶ View outputs ▶ AO1 current	Device setup ▶ Process variables ▶ Analog out 1	0.000 to +99.999 Number of decimal places: 3	0.000 to +99.999 Number of decimal places: 3	R	-	mA	P.76
1-4	Process variables root menu ▶ Device variables ▶ Totalizer1	Device setup ▶ Process variables ▶ Totalizer ▶ Totalizer 1	-999999 to +999999 Number of decimal places: 0 to 5	-99999999 to +99999999 Number of decimal places: 0 to 5	R	-	No.4-1	P.57
1-5	Process variables root menu ▶ Device variables ▶ Totalizer2	Device setup ▶ Process variables ▶ Totalizer ▶ Totalizer 2	-999999 to +999999 Number of decimal places: 0 to 5	-99999999 to +99999999 Number of decimal places: 0 to 5	R	-	No.4-11	P.57
1-6	Process variables root menu ▶ Device variables ▶ Totalizer3	Device setup ▶ Process variables ▶ Totalizer ▶ Totalizer 3	-999999 to +999999 Number of decimal places: 0 to 5	-99999999 to +99999999 Number of decimal places: 0 to 5	R	-	No.4-21	P.57
1-7	Process variables root menu ▶ Totalizer count ▶ Totalizer1 count	Device setup ▶ Process variables ▶ Totalizer ▶ Totalizer 1 count	-INF <sup>2</sup> to +INF <sup>2</sup> Number of decimal places: 0	-99999999 to +99999999 Number of decimal places: 0	R	-	-	P.58
1-8	Process variables root menu ▶ Totalizer count ▶ Totalizer2 count	Device setup ▶ Process variables ▶ Totalizer ▶ Totalizer 2 count	-INF <sup>2</sup> to +INF <sup>2</sup> Number of decimal places: 0	-99999999 to +99999999 Number of decimal places: 0	R	-	-	P.58
1-9	Process variables root menu ▶ Totalizer count ▶ Totalizer3 count	Device setup ▶ Process variables ▶ Totalizer ▶ Totalizer 3 count	-INF <sup>2</sup> to +INF <sup>2</sup> Number of decimal places: 0	-99999999 to +99999999 Number of decimal places: 0	R	-	-	P.58
1-10	Process variables root menu ▶ Device variables ▶ Velocity	Device setup ▶ Process variables ▶ Velocity	-999999 to +999999 Number of decimal places: 0 to 5	-999999 to +999999 Number of decimal places: 0 to 5	R	-	No.3-15	P.42
1-11	Process variables root menu ▶ Device variables ▶ Volume flow	Device setup ▶ Process variables ▶ Volume	-999999 to +999999 Number of decimal places: 0 to 5	-999999 to +999999 Number of decimal places: 0 to 5	R	-	No.3-16/ No.3-19	P.42
1-12	Process variables root menu ▶ Device variables ▶ Mass flow	Device setup ▶ Process variables ▶ Mass	-999999 to +999999 Number of decimal places: 0 to 5	-999999 to +999999 Number of decimal places: 0 to 5	R	-	No.3-17/ No.3-19	P.42
1-13 (G)	Process variables root menu ▶ View outputs ▶ AQ2 current	Device setup ▶ Process variables ▶ Analog out 2	0.000 to +99.999 Number of decimal places: 3	0.000 to +99.999 Number of decimal places: 3	R	-	mA	P.76

\*2: The range of single precision float (IEEE 754).

## 5.2 Easy Configuration Parameters

These parameters are frequently used general functions. Parameters for No.2-2 to 2-14 can be set by using the Easy setup wizard function.

No.	Parameter Name		Data Range		RW	Default Value	Unit	Reference
	HART	Display	HART	Display				
2-1	Device root menu ▶ Detailed setup ▶ Display ▶ Display operation configuration ▶ Language	Device setup ▶ Language	English French German Italian Spanish Portuguese Russian Chinese Japanese	English French German Italian Spanish Portuguese Russian Chinese Japanese	RW	English	-	P.120
2-2	Device root menu ▶ Basic setup ▶ Volume flow ▶ Volume flow damping AO/frequency	Device setup ▶ Easy setup wizard ▶ Volume ▶ Damp AO/F	+0.1 to +200.0 Number of decimal places: 1	+0.1 to +200.0 Number of decimal places: 1	RW	3.0	s	P.45
2-3	Device root menu ▶ Basic setup ▶ Volume flow ▶ Volume flow damping pulse/total	Device setup ▶ Easy setup wizard ▶ Volume ▶ Damp pls/ttl	0.0 to +200.0 Number of decimal places: 1	0.0 to +200.0 Number of decimal places: 1	RW	3.0	s	P.46
2-4	Device root menu ▶ Basic setup ▶ Volume flow ▶ Volume flow unit	Device setup ▶ Easy setup wizard ▶ Volume ▶ Unit	l(Megaliter) m <sup>3</sup> kl(Kiloliter) l(liter) cm <sup>3</sup>	l(Megaliter) m <sup>3</sup> kl(kiloliter) l(liter) cm <sup>3</sup>	RW	m <sup>3</sup> *1	-	P.43
2-5	Device root menu ▶ Basic setup ▶ Volume flow ▶ Time unit	Device setup ▶ Easy setup wizard ▶ Volume ▶ Time unit	/s /min /h	/s /min /h	RW	/h *1	-	P.43
2-6	Device root menu ▶ Basic setup ▶ Volume flow ▶ Volume flow span	Device setup ▶ Easy setup wizard ▶ Volume ▶ Span	+0.00001 to +INF <sup>2</sup> Number of decimal places: 0 to 5	+0.00001 to +999999 Number of decimal places: 0 to 5	RW	1.00 *1	No.3-16/ No.3-19	P.44
2-7	Device root menu ▶ Detailed setup ▶ Pulse/Status ▶ Pulse/Status output1 ▶ Pulse1 rate unit	Device setup ▶ Easy setup wizard ▶ Pulse/Status out ▶ P1 unit	n unit/P u unit/P m unit/P Unit/P k unit/P M unit/P n P/unit u P/unit m P/unit P/unit k P/unit M P/unit	n unit/P u unit/P m unit/P Unit/P k unit/P M unit/P n P/unit u P/unit m P/unit P/unit k P/unit M P/unit	RW	Unit/P *1	-	P.68
2-8	Device root menu ▶ Detailed setup ▶ Pulse/Status ▶ Pulse/Status output1 ▶ Pulse1 rate value	Device setup ▶ Easy setup wizard ▶ Pulse/Status out ▶ P1 val	0.00000 to +INF <sup>2</sup> Number of decimal places: 0 to 5	0.00000 to +999999 Number of decimal places: 0 to 5	RW	0.0	No.5-4	P.67
2-9	Device root menu ▶ Detailed setup ▶ Pulse/Status ▶ Pulse/Status output1 ▶ Frequency1 at 0%	Device setup ▶ Easy setup wizard ▶ Pulse/Status out ▶ F1 at 0%	0 to 12500 Number of decimal places: 0	0 to 12500 Number of decimal places: 0	RW	0	Hz	P.69
2-10	Device root menu ▶ Detailed setup ▶ Pulse/Status ▶ Pulse/Status output1 ▶ Frequency1 at 100%	Device setup ▶ Easy setup wizard ▶ Pulse/Status out ▶ F1 at 100%	0 to 12500 Number of decimal places: 0	0 to 12500 Number of decimal places: 0	RW	0	Hz	P.69

\*1: Determined based on the information about specified items at the time of ordering and the sensor to be combined with.

\*2: The range of single precision float (IEEE 754).

No.	Parameter Name		Data Range		RW	Default Value	Unit	Reference
	HART	Display	HART	Display				
2-11	Device root menu ▶ Detailed setup ▶ Display ▶ Line select ▶ Display select1	Device setup ▶ Easy setup wizard ▶ Display set ▶ Line 1	Flow rate(%) PV Velocity Volume flow Mass flow Flow rate(%Bar) Calorie <sup>(G)</sup> Totalizer1 Totalizer2 Totalizer3 Tag number Long tag Commun Protocol Adhesion Analog out1 Analog out2 <sup>(G)</sup> Flow noise level <sup>(G)</sup> Totalizer1 count Totalizer2 count Totalizer3 count	Flow rate(%) PV Velocity Volume flow Mass flow Flow rate(%Bar) Calorie <sup>(G)</sup> Totalizer 1 Totalizer 2 Totalizer 3 Tag number Long tag Commun protocol Adhesion Analog out 1 Analog out 2 <sup>(G)</sup> Flow noise level <sup>(G)</sup> Totalizer 1 count Totalizer 2 count Totalizer 3 count	RW	PV	-	P.121
2-12	Device root menu ▶ Detailed setup ▶ Display ▶ Line select ▶ Display select2	Device setup ▶ Easy setup wizard ▶ Display set ▶ Line 2	None Flow rate(%) PV Velocity Volume flow Mass flow Flow rate(%Bar) Calorie <sup>(G)</sup> Totalizer1 Totalizer2 Totalizer3 Tag number Long tag Commun Protocol Adhesion Analog out1 Analog out2 <sup>(G)</sup> Flow noise level <sup>(G)</sup> Totalizer1 count Totalizer2 count Totalizer3 count	None Flow rate(%) PV Velocity Volume flow Mass flow Flow rate(%Bar) Calorie <sup>(G)</sup> Totalizer 1 Totalizer 2 Totalizer 3 Tag number Long tag Commun protocol Adhesion Analog out 1 Analog out 2 <sup>(G)</sup> Flow noise level <sup>(G)</sup> Totalizer 1 count Totalizer 2 count Totalizer 3 count	RW	Flow rate(%)	-	P.121
2-13	Device root menu ▶ Detailed setup ▶ Display ▶ Line select ▶ Display select3	Device setup ▶ Easy setup wizard ▶ Display set ▶ Line 3	Totalizer1 Totalizer2 Totalizer3 Tag number Long tag Commun Protocol Adhesion Analog out1 Analog out2 <sup>(G)</sup> Flow noise level <sup>(G)</sup> Totalizer1 count Totalizer2 count Totalizer3 count	Totalizer 1 Totalizer 2 Totalizer 3 Tag number Long tag Commun protocol Adhesion Analog out 1 Analog out 2 <sup>(G)</sup> Flow noise level <sup>(G)</sup> Totalizer 1 count Totalizer 2 count Totalizer 3 count	RW	Analog out 1	-	P.121
2-14	Device root menu ▶ Basic setup ▶ Autozero ▶ Autozero Exe	Device setup ▶ Easy setup wizard ▶ Autozero exe	Not execute Execute	Not execute Execute	RW	Not execute	-	P.55

\*1: Determined based on the information about specified items at the time of ordering and the sensor to be combined with.

\*2: The range of single precision float (IEEE 754).

## 5.3 Basic Configuration Parameters

These parameters are related to basic settings, such as a flow sensor.

No.	Parameter Name		Data Range		RW	Default Value	Unit	Reference
	HART	Display	HART	Display				
3-1	Device root menu ▶ Detailed setup ▶ Process variables ▶ Velocity ▶ Velocity damping AO/ frequency	Device setup ▶ Detailed setup ▶ Pro var ▶ Velocity ▶ Damp AO/F	+0.1 to +200.0 Number of decimal places: 1	+0.1 to +200.0 Number of decimal places: 1	RW	3.0	s	P.45
3-2	Device root menu ▶ Detailed setup ▶ Process variables ▶ Velocity ▶ Velocity damping pulse/total	Device setup ▶ Detailed setup ▶ Pro var ▶ Velocity ▶ Damp pls/ttl	0.0 to +200.0 Number of decimal places: 1	0.0 to +200.0 Number of decimal places: 1	RW	3.0	s	P.46
3-3	Device root menu ▶ Detailed setup ▶ Process variables ▶ Volume flow ▶ Volume flow damping AO/frequency	Device setup ▶ Detailed setup ▶ Pro var ▶ Volume ▶ Damp AO/F	+0.1 to +200.0 Number of decimal places: 1	+0.1 to +200.0 Number of decimal places: 1	RW	3.0	s	P.45
3-4	Device root menu ▶ Detailed setup ▶ Process variables ▶ Volume flow ▶ Volume flow damping pulse/total	Device setup ▶ Detailed setup ▶ Pro var ▶ Volume ▶ Damp pls/ttl	0.0 to +200.0 Number of decimal places: 1	0.0 to +200.0 Number of decimal places: 1	RW	3.0	s	P.46
3-5	Device root menu ▶ Detailed setup ▶ Process variables ▶ Mass flow ▶ Mass flow damping AO/frequency	Device setup ▶ Detailed setup ▶ Pro var ▶ Mass ▶ Damp AO/F	+0.1 to +200.0 Number of decimal places: 1	+0.1 to +200.0 Number of decimal places: 1	RW	3.0	s	P.45
3-6	Device root menu ▶ Detailed setup ▶ Process variables ▶ Mass flow ▶ Mass flow damping pulse/total	Device setup ▶ Detailed setup ▶ Pro var ▶ Mass ▶ Damp pls/ttl	0.0 to +200.0 Number of decimal places: 1	0.0 to +200.0 Number of decimal places: 1	RW	3.0	s	P.46
3-7	Device root menu ▶ Detailed setup ▶ Process variables ▶ Calorific ▶ Calorific value damping AO/ frequency	Device setup ▶ Detailed setup ▶ Pro var ▶ Calorie ▶ Damp AO/F	+0.1 to +200.0 Number of decimal places: 1	+0.1 to +200.0 Number of decimal places: 1	RW	3.0	s	P.45
3-8	Device root menu ▶ Detailed setup ▶ Process variables ▶ Calorific ▶ Calorific value damping pulse/total	Device setup ▶ Detailed setup ▶ Pro var ▶ Calorie ▶ Damp pls/ttl	0.0 to +200.0 Number of decimal places: 1	0.0 to +200.0 Number of decimal places: 1	RW	3.0	s	P.46
3-9	Device root menu ▶ Detailed setup ▶ Sensor ▶ Low MF	Device setup ▶ Detailed setup ▶ Sensor ▶ Low MF	+0.0100 to +3.0000 Number of decimal places: 4	+0.0100 to +3.0000 Number of decimal places: 4	RW	1.0000 <sup>*1</sup>	-	P.49
3-10	Device root menu ▶ Detailed setup ▶ Sensor ▶ High MF	Device setup ▶ Detailed setup ▶ Sensor ▶ High MF	+0.0100 to +3.0000 Number of decimal places: 4	+0.0100 to +3.0000 Number of decimal places: 4	RW	1.0000 <sup>*1</sup>	-	P.49
3-11	Device root menu ▶ Detailed setup ▶ Sensor ▶ Flow sensor select	Device setup ▶ Detailed setup ▶ Sensor ▶ Flow sensor sel	ADMAG AXG <sup>(G)</sup> ADMAG AXW ADMAG AXF <sup>(G)</sup> ADMAG ADMAG AE <sup>(G)</sup> ADMAG SE YEW MAG Calibrator Other1 Other2 Other3 <sup>(G)</sup>	ADMAG AXG <sup>(G)</sup> ADMAG AXW ADMAG AXF <sup>(G)</sup> ADMAG ADMAG AE <sup>(G)</sup> ADMAG SE YEW MAG Calibrator Other 1 Other 2 Other 3 <sup>(G)</sup>	RW	ADMAG AXG <sup>*1</sup>	-	P.50
3-12	Device root menu ▶ Detailed setup ▶ Sensor ▶ Nominal size unit	Device setup ▶ Detailed setup ▶ Sensor ▶ Nominal size unit	mm inch	mm inch	RW	mm	-	P.51
3-13	Device root menu ▶ Detailed setup ▶ Sensor ▶ Nominal size	Device setup ▶ Detailed setup ▶ Sensor ▶ Nominal size	+0.01000 to +3000.0 Number of decimal places: 0 to 5	+0.01000 to +3000.0 Number of decimal places: 0 to 5	RW	100 <sup>*1</sup>	No.3-12	P.51

\*1: Determined based on the information about specified items at the time of ordering and the sensor to be combined with.

\*2: The range of single precision float (IEEE 754).

No.	Parameter Name		Data Range		R/W	Default Value	Unit	Reference
	HART	Display	HART	Display				
3-14	Device root menu ▶ Detailed setup ▶ Process variables ▶ PV flow select	Device setup ▶ Detailed setup ▶ Pro var ▶ PV flow select	Velocity Volume Mass Diag <sup>(G)</sup>	Velocity Volume Mass Diag <sup>(G)</sup>	RW	Volume <sup>11</sup>	-	P.41
3-15	Device root menu ▶ Detailed setup ▶ Process variables ▶ Velocity ▶ Velocity unit	Device setup ▶ Detailed setup ▶ Pro var ▶ Velocity Unit	m/s ft/s	m/s ft/s	RW	m/s <sup>11</sup>	-	P.43
3-16	Device root menu ▶ Detailed setup ▶ Process variables ▶ Volume flow ▶ Volume flow unit	Device setup ▶ Detailed setup ▶ Pro var ▶ Volume Unit	Ml(Megaliter) m <sup>3</sup> kl(Kiloliter) l(liter) cm <sup>3</sup> kcf cf mcf Mgal(US) kgal(US) gal(US) mgal(US) kbb(US Oil) bbl(US Oil) mbb(US Oil) ubbl(US Oil) kbb(US Beer) bb(US Beer) mbb(US Beer) ubbl(US Beer)	Ml(Megaliter) m <sup>3</sup> kl(kiloliter) l(liter) cm <sup>3</sup> kcf cf mcf Mgal(US) kgal(US) gal(US) mgal(US) kbb(US Oil) bbl(US Oil) mbb(US Oil) ubbl(US Oil) kbb(US Beer) bb(US Beer) mbb(US Beer) ubbl(US Beer)	RW	m <sup>3</sup> <sup>11</sup>	-	P.43
3-17	Device root menu ▶ Detailed setup ▶ Process variables ▶ Mass flow ▶ Mass flow unit	Device setup ▶ Detailed setup ▶ Pro var ▶ Mass Unit	t kg g klb lb	t kg g klb lb	RW	kg <sup>11</sup>	-	P.43
3-18	Device root menu ▶ Detailed setup ▶ Process variables ▶ Calorie ▶ Caloric unit	Device setup ▶ Detailed setup ▶ Pro var ▶ Calorie Unit	MJ kJ J kcal cal BTU	MJ kJ J kcal cal BTU	RW	J	-	P.43
3-19 (G)	Device root menu ▶ Detailed setup ▶ Process variables ▶ Volume flow ▶ Time unit or Device root menu ▶ Detailed setup ▶ Pro var ▶ Mass ▶ Process variables ▶ Mass flow ▶ Time unit or Device setup ▶ Detailed setup ▶ Pro var ▶ Calorie ▶ Time unit or Device root menu ▶ Detailed setup ▶ Process variables ▶ Calorie ▶ Time unit	Device setup ▶ Detailed setup ▶ Pro var ▶ Volume ▶ Time unit or Device setup ▶ Detailed setup ▶ Pro var ▶ Mass ▶ Time unit or Device setup ▶ Detailed setup ▶ Pro var ▶ Calorie ▶ Time unit	/s /min /h /d	/s /min /h /d	RW	/h <sup>11</sup>	-	P.43
3-20	Device root menu ▶ Detailed setup ▶ Process variables ▶ Velocity ▶ Velocity span	Device setup ▶ Detailed setup ▶ Pro var ▶ Velocity Span	+0.00001 to +INF <sup>2</sup> Number of decimal places: 0 to 5	+0.00001 to +999999 Number of decimal places: 0 to 5	RW	1.00000 <sup>11</sup>	No.3-15	P.44
3-21	Device root menu ▶ Detailed setup ▶ Process variables ▶ Volume flow ▶ Volume flow span	Device setup ▶ Detailed setup ▶ Pro var ▶ Volume Span	+0.00001 to +INF <sup>2</sup> Number of decimal places: 0 to 5	+0.00001 to +999999 Number of decimal places: 0 to 5	RW	1.00000 <sup>11</sup>	No.3-16/ No.3-19	P.44
3-22	Device root menu ▶ Detailed setup ▶ Process variables ▶ Mass flow ▶ Mass flow span	Device setup ▶ Detailed setup ▶ Pro var ▶ Mass ▶ Span	+0.00001 to +INF <sup>2</sup> Number of decimal places: 0 to 5	+0.00001 to +999999 Number of decimal places: 0 to 5	RW	1.00000 <sup>11</sup>	No.3-17/ No.3-19 [kg/h]	P.44
3-23 (G)	Device root menu ▶ Detailed setup ▶ Process variables ▶ Calorie ▶ Caloric flow span	Device setup ▶ Detailed setup ▶ Pro var ▶ Calorie Span	+0.00000 to +INF <sup>2</sup> Number of decimal places: 0 to 5	+0.00001 to +999999 Number of decimal places: 0 to 5	RW	1.00000	No.3-18/ No.3-19 [J/h]	P.44

\*1: Determined based on the information about specified items at the time of ordering and the sensor to be combined with.

\*2: The range of single precision float (IEEE 754).



No.	Parameter Name		Data Range		R/W	Default Value	Unit	Reference
	HART	Display	HART	Display				
3-24	Device root menu ▶ Detailed setup ▶ Process variables ▶ Velocity check	Device setup ▶ Detailed setup ▶ Pro var ▶ Velocity check	-99.999 to +99.999 Number of decimal places: 3	-99.999 to +99.999 Number of decimal places: 3	R	-	m/s	P.52
3-25	Device root menu ▶ Detailed setup ▶ Use span ▶ User span select AO1	Device setup ▶ Detailed setup ▶ User Span ▶ User span AO1 ▶ Select	No Yes	No Yes	RW	No	-	P.53
3-26	Device root menu ▶ Detailed setup ▶ Use span ▶ User unit AO1	Device setup ▶ Detailed setup ▶ User Span ▶ User span AO1 ▶ Unit	ASCII 8 characters	ASCII 8 characters	RW	All Space	-	P.53
3-27	Device root menu ▶ Detailed setup ▶ Use span ▶ User span AO1	Device setup ▶ Detailed setup ▶ User Span ▶ User span AO1 ▶ Span	+0.00001 to +INF <sup>*2</sup> Number of decimal places: 0 to 5	+0.00001 to +999999 Number of decimal places: 0 to 5	RW	100.000	-	P.54
3-28 (G)	Device root menu ▶ Detailed setup ▶ Use span ▶ User span select AO2	Device setup ▶ Detailed setup ▶ User Span ▶ User span AO2 ▶ Select	No Yes	No Yes	RW	No	-	P.53
3-29 (G)	Device root menu ▶ Detailed setup ▶ Use span ▶ User unit AO2	Device setup ▶ Detailed setup ▶ User Span ▶ User span AO2 ▶ Unit	ASCII 8 characters	ASCII 8 characters	RW	All Space	-	P.53
3-30 (G)	Device root menu ▶ Detailed setup ▶ Use span ▶ User span AO2	Device setup ▶ Detailed setup ▶ User Span ▶ User span AO2 ▶ Span	+0.00001 to +INF <sup>*2</sup> Number of decimal places: 0 to 5	+0.00001 to +999999 Number of decimal places: 0 to 5	RW	100.000	-	P.54
3-31	Device root menu ▶ Basic setup ▶ Autozero ▶ Autozero Exe	Device setup ▶ Diag/Service ▶ Autozero ▶ Execute	Not execute Execute	Not execute Execute	RW	Not execute	-	P.55
3-32	Device root menu ▶ Basic setup ▶ Autozero ▶ Zero value	Device setup ▶ Diag/Service ▶ Autozero ▶ Result Zero value	-99.999 to +99.999 Number of decimal places: 3	-99.999 to +99.999 Number of decimal places: 3	RW	0.000	cm/s	P.56

\*1: Determined based on the information about specified items at the time of ordering and the sensor to be combined with.

\*2: The range of single precision float (IEEE 754).

# 5.4 Totalization Configuration Parameters

These parameters are related to the totalization function.

No.	Parameter Name		Data Range		R/W	Default Value	Unit	Reference
	HART	Display	HART	Display				
4-1	Device root menu ► Detailed setup ► Totalizer ► Totalizer1 ► Total1 unit	Device setup ► Detailed setup ► Totalizer ► Totalizer 1 ► Unit	Ml(Megaliter) m <sup>3</sup> k(Kiloliter) l(liter) cm <sup>3</sup> t kg g kcf cf mcf Mgal(US) kgal(US) gal(US) mgal(US) kbb(US Oil) bb(US Oil) mbb(US Oil) ubb(US Oil) kbb(US Beer) bb(US Beer) mbb(US Beer) ubb(US Beer) klb(US) lb(US)	Ml(Megaliter) m <sup>3</sup> k(kiloliter) l(liter) cm <sup>3</sup> t kg g kcf cf mcf Mgal(US) kgal(US) gal(US) mgal(US) kbb(US Oil) bb(US Oil) mbb(US Oil) ubb(US Oil) kbb(US Beer) bb(US Beer) mbb(US Beer) ubb(US Beer) klb(US) lb(US)	R	-	-	P.57
4-2	Device root menu ► Detailed setup ► Totalizer ► Totalizer1 ► Total1 count unit	Device setup ► Detailed setup ► Totalizer ► Totalizer 1 ► Count unit	ASCII 8 characters	ASCII 8 characters	RW	All Space	-	P.58
4-3	Device root menu ► Detailed setup ► Totalizer ► Totalizer1 ► Total1 conv factor	Device setup ► Detailed setup ► Totalizer ► Totalizer 1 ► Conv factor	-INF <sup>2</sup> to +INF <sup>2</sup> Unable to input 0 Number of decimal places: 0 to 5	-999999 to +999999 Number of decimal places: 0 to 5	RW	1.00000	No.4-1	P.58
4-4	Device root menu ► Detailed setup ► Totalizer ► Totalizer1 ► Total1 low cut	Device setup ► Detailed setup ► Totalizer ► Totalizer 1 ► Low cut	0.00000 to +INF <sup>2</sup> Number of decimal places: 0 to 5	0.00000 to +999999 Number of decimal places: 0 to 5	RW	0.00000 <sup>-1</sup>	Volumetric flow rate: No.3-16/ No.3-19 Mass flow rate: No.3-17/ No.3-19 Calorie: No.3-18/ No.3-19	P.47
4-5	Device root menu ► Detailed setup ► Totalizer ► Totalizer1 ► Total1 fail opts	Device setup ► Detailed setup ► Totalizer ► Totalizer 1 ► Failure opts	Measured value Stop Last valid	Measured value Stop Last valid	RW	Stop <sup>4</sup>	-	P.60
4-6	Device root menu ► Detailed setup ► Totalizer ► Totalizer1 ► Total1 options	Device setup ► Detailed setup ► Totalizer ► Totalizer 1 ► Options	Balanced Absolute Only positive Only negative Hold	Balanced Absolute Only positive Only negative Hold	RW	Only positive	-	P.61
4-7	Device root menu ► Detailed setup ► Totalizer ► Totalizer1 ► Total1 Start/Stop	Device setup ► Detailed setup ► Totalizer ► Totalizer 1 ► Start/Stop	Stop Start	Stop Start	RW	Stop	-	P.61
4-8	Device root menu ► Detailed setup ► Totalizer ► Totalizer1 ► Total1 Reset/Preset	Device setup ► Detailed setup ► Totalizer ► Totalizer 1 ► Reset/Preset	Not execute Reset Preset	Not execute Reset Preset	RW	Not execute	-	P.62
4-9	Device root menu ► Detailed setup ► Totalizer ► Totalizer1 ► Total1 preset value	Device setup ► Detailed setup ► Totalizer ► Totalizer 1 ► Preset value	-INF <sup>2</sup> to +INF <sup>2</sup> Number of decimal places: 0 to 5	-999999 to +999999 Number of decimal places: 0 to 5	RW	0.00000	Volumetric flow rate: No.3-16 Mass flow rate: No.3-17 Calorie: No.3-18	P.62

\*1: Determined based on the information about specified items at the time of ordering and the sensor to be combined with.

\*2: The range of single precision float (IEEE 754).

\*3: Displayed only when analog input is valid.

\*4: When Main soft rev (Main board revision/Main soft rev) is R2.01.01 or earlier, the default value is "Run".

No.	Parameter Name		Data Range		R/W	Default Value	Unit	Reference
	HART	Display	HART	Display				
4-10	Device root menu ▶ Detailed setup ▶ Totalizer ▶ Totalizer1 ▶ Total1 set point	Device setup ▶ Detailed setup ▶ Totalizer ▶ Totalizer 1 ▶ Set point	0.00000 to +INF <sup>*2</sup> Number of decimal places: 0 to 5	0.00000 to +999999 Number of decimal places: 0 to 5	RW	0.00000	Volumetric flow rate: No.3-16 Mass flow rate: No.3-17 Calorie: No.3-18	P.59
4-11	Device root menu ▶ Detailed setup ▶ Totalizer ▶ Totalizer2 ▶ Total2 unit	Device setup ▶ Detailed setup ▶ Totalizer ▶ Totalizer 2 ▶ Unit	Ml(Megaliter) m <sup>3</sup> kl(Kiloliter) l(liter) cm <sup>3</sup> t kg g kcf cf mcf Mgal(US) kgal(US) gal(US) mgal(US) kbb(US Oil) bbl(US Oil) mbb(US Oil) ubbl(US Oil) kbb(US Beer) bb(US Beer) mbb(US Beer) ubbl(US Beer) klb(US) lb(US) MJ <sup>3</sup> kJ <sup>3</sup> J <sup>3</sup> kcal <sup>3</sup> cal <sup>3</sup> BTU <sup>3</sup>	Ml(Megaliter) m <sup>3</sup> kl(kiloliter) l(liter) cm <sup>3</sup> t kg g kcf cf mcf Mgal(US) kgal(US) gal(US) mgal(US) kbb(US Oil) bbl(US Oil) mbb(US Oil) ubbl(US Oil) kbb(US Beer) bb(US Beer) mbb(US Beer) ubbl(US Beer) klb(US) lb(US) MJ <sup>3</sup> kJ <sup>3</sup> J <sup>3</sup> kcal <sup>3</sup> cal <sup>3</sup> BTU <sup>3</sup>	RW	m <sup>3</sup>	-	P.57
4-12	Device root menu ▶ Detailed setup ▶ Totalizer ▶ Totalizer2 ▶ Total2 count unit	Device setup ▶ Detailed setup ▶ Totalizer ▶ Totalizer 2 ▶ Count unit	ASCII 8 characters	ASCII 8 characters	RW	All Space	-	P.58
4-13	Device root menu ▶ Detailed setup ▶ Totalizer ▶ Totalizer2 ▶ Total2 conv factor	Device setup ▶ Detailed setup ▶ Totalizer ▶ Totalizer 2 ▶ Conv factor	-INF <sup>*2</sup> to +INF <sup>*2</sup> Unable to input 0 Number of decimal places: 0 to 5	-999999 to +999999 Number of decimal places: 0 to 5	RW	1.00000	No.4-11	P.58
4-14	Device root menu ▶ Detailed setup ▶ Totalizer ▶ Totalizer2 ▶ Total2 low cut	Device setup ▶ Detailed setup ▶ Totalizer ▶ Totalizer 2 ▶ Low cut	0.00000 to +INF <sup>*2</sup> Number of decimal places: 0 to 5	0.00000 to +999999 Number of decimal places: 0 to 5	RW	0.00000	No.4-11/ No.3-19	P.47
4-15	Device root menu ▶ Detailed setup ▶ Totalizer ▶ Totalizer2 ▶ Total2 fail opts	Device setup ▶ Detailed setup ▶ Totalizer ▶ Totalizer 2 ▶ Failure opts	Measured value Stop Last valid	Measured value Stop Last valid	RW	Stop <sup>*4</sup>	-	P.60
4-16	Device root menu ▶ Detailed setup ▶ Totalizer ▶ Totalizer2 ▶ Total2 options	Device setup ▶ Detailed setup ▶ Totalizer ▶ Totalizer 2 ▶ Options	Balanced Absolute Only positive Only negative Hold	Balanced Absolute Only positive Only negative Hold	RW	Only negative	-	P.61
4-17	Device root menu ▶ Detailed setup ▶ Totalizer ▶ Totalizer2 ▶ Total2 Start/Stop	Device setup ▶ Detailed setup ▶ Totalizer ▶ Totalizer 2 ▶ Start/Stop	Stop Start	Stop Start	RW	Stop	-	P.61
4-18	Device root menu ▶ Detailed setup ▶ Totalizer ▶ Totalizer2 ▶ Total2 Reset/Preset	Device setup ▶ Detailed setup ▶ Totalizer ▶ Totalizer 2 ▶ Reset/Preset	Not execute Reset Preset	Not execute Reset Preset	RW	Not execute	-	P.62

\*1: Determined based on the information about specified items at the time of ordering and the sensor to be combined with.

\*2: The range of single precision float (IEEE 754).

\*3: Displayed only when analog input is valid.

\*4: When Main soft rev (Main board revision/Main soft rev) is R2.01.01 or earlier, the default value is "Run".

No.	Parameter Name		Data Range		R/W	Default Value	Unit	Reference
	HART	Display	HART	Display				
4-19	Device root menu ▶ Detailed setup ▶ Totalizer ▶ Totalizer2 ▶ Total2 preset value	Device setup ▶ Detailed setup ▶ Totalizer ▶ Totalizer 2 ▶ Preset value	-INF <sup>2</sup> to +INF <sup>2</sup> Number of decimal places: 0 to 5	-999999 to +999999 Number of decimal places: 0 to 5	RW	0.00000	No.4-11	P.62
4-20	Device root menu ▶ Detailed setup ▶ Totalizer ▶ Totalizer2 ▶ Total2 set point	Device setup ▶ Detailed setup ▶ Totalizer ▶ Totalizer 2 ▶ Set point	0.00000 to +INF <sup>2</sup> Number of decimal places: 0 to 5	0.00000 to +999999 Number of decimal places: 0 to 5	RW	0.00000	No.4-11	P.59
4-21	Device root menu ▶ Detailed setup ▶ Totalizer ▶ Totalizer3 ▶ Total3 unit	Device setup ▶ Detailed setup ▶ Totalizer ▶ Totalizer 3 ▶ Unit	l(Megaliter) m <sup>3</sup> kl(Kiloliter) l(liter) cm <sup>3</sup> t kg g kcf cf mcf Mgal(US) kgal(US) gal(US) mgal(US) kbb(US Oil) bb(US Oil) mbb(US Oil) ubb(US Oil) kbb(US Beer) bb(US Beer) mbb(US Beer) ubb(US Beer) klb(US) lb(US) MJ <sup>3</sup> kJ <sup>3</sup> J <sup>3</sup> kcal <sup>3</sup> cal <sup>3</sup> BTU <sup>3</sup>	l(Megaliter) m <sup>3</sup> kl(kiloliter) l(liter) cm <sup>3</sup> t kg g kcf cf mcf Mgal(US) kgal(US) gal(US) mgal(US) kbb(US Oil) bb(US Oil) mbb(US Oil) ubb(US Oil) kbb(US Beer) bb(US Beer) mbb(US Beer) ubb(US Beer) klb(US) lb(US) MJ <sup>3</sup> kJ <sup>3</sup> J <sup>3</sup> kcal <sup>3</sup> cal <sup>3</sup> BTU <sup>3</sup>	RW	m <sup>3</sup>	-	P.57
4-22	Device root menu ▶ Detailed setup ▶ Totalizer ▶ Totalizer3 ▶ Total3 count unit	Device setup ▶ Detailed setup ▶ Totalizer ▶ Totalizer 3 ▶ Count unit	ASCII 8 characters	ASCII 8 characters	RW	All Space	-	P.58
4-23	Device root menu ▶ Detailed setup ▶ Totalizer ▶ Totalizer3 ▶ Total3 conv factor	Device setup ▶ Detailed setup ▶ Totalizer ▶ Totalizer 3 ▶ Conv factor	-INF <sup>2</sup> to +INF <sup>2</sup> Unable to input 0 Number of decimal places: 0 to 5	-999999 to +999999 Number of decimal places: 0 to 5	RW	1.00000	No.4-21	P.58
4-24	Device root menu ▶ Detailed setup ▶ Totalizer ▶ Totalizer3 ▶ Total3 low cut	Device setup ▶ Detailed setup ▶ Totalizer ▶ Totalizer 3 ▶ Low cut	0.00000 to +INF <sup>2</sup> Number of decimal places: 0 to 5	0.00000 to +999999 Number of decimal places: 0 to 5	RW	0.00000	No.4-21/ No.3-19	P.47
4-25	Device root menu ▶ Detailed setup ▶ Totalizer ▶ Totalizer3 ▶ Total3 fail opts	Device setup ▶ Detailed setup ▶ Totalizer ▶ Totalizer 3 ▶ Failure opts	Measured value Stop Last valid	Measured value Stop Last valid	RW	Stop <sup>4</sup>	-	P.60
4-26	Device root menu ▶ Detailed setup ▶ Totalizer ▶ Totalizer3 ▶ Total3 options	Device setup ▶ Detailed setup ▶ Totalizer ▶ Totalizer 3 ▶ Options	Balanced Absolute Only positive Only negative Hold	Balanced Absolute Only positive Only negative Hold	RW	Balanced	-	P.61
4-27	Device root menu ▶ Detailed setup ▶ Totalizer ▶ Totalizer3 ▶ Total3 Start/Stop	Device setup ▶ Detailed setup ▶ Totalizer ▶ Totalizer 3 ▶ Start/Stop	Stop Start	Stop Start	RW	Stop	-	P.61
4-28	Device root menu ▶ Detailed setup ▶ Totalizer ▶ Totalizer3 ▶ Total3 Reset/Preset	Device setup ▶ Detailed setup ▶ Totalizer ▶ Totalizer 3 ▶ Reset/Preset	Not execute Reset Preset	Not execute Reset Preset	RW	Not execute	-	P.62

\*1: Determined based on the information about specified items at the time of ordering and the sensor to be combined with.

\*2: The range of single precision float (IEEE 754).

\*3: Displayed only when analog input is valid.

\*4: When Main soft rev (Main board revision/Main soft rev) is R2.01.01 or earlier, the default value is "Run".

No.	Parameter Name		Data Range		R/W	Default Value	Unit	Reference
	HART	Display	HART	Display				
4-29	Device root menu ▶ Detailed setup ▶ Totalizer ▶ Totalizer3 ▶ Total3 preset value	Device setup ▶ Detailed setup ▶ Totalizer ▶ Totalizer 3 ▶ Preset value	-INF <sup>2</sup> to +INF <sup>2</sup> Number of decimal places: 0 to 5	-999999 to +999999 Number of decimal places: 0 to 5	RW	0.00000	No.4-21	P.62
4-30	Device root menu ▶ Detailed setup ▶ Totalizer ▶ Totalizer3 ▶ Total3 set point	Device setup ▶ Detailed setup ▶ Totalizer ▶ Totalizer 3 ▶ Set point	0.00000 to +INF <sup>2</sup> Number of decimal places: 0 to 5	0.00000 to +999999 Number of decimal places: 0 to 5	RW	0.00000	No.4-21	P.59
4-31	Device root menu ▶ Detailed setup ▶ Totalizer ▶ Totalizer reset mode	Device setup ▶ Detailed setup ▶ Totalizer ▶ Reset mode	Off On	Off On	RW	On	-	P.59

\*1: Determined based on the information about specified items at the time of ordering and the sensor to be combined with.

\*2: The range of single precision float (IEEE 754).

\*3: Displayed only when analog input is valid.

\*4: When Main soft rev (Main board revision/Main soft rev) is R2.01.01 or earlier, the default value is "Run".

# 5.5 Pulse Output Configuration Parameters

These parameters are related to the pulse/status output 1/2.

No.	Parameter Name		Data Range		RW	Default Value	Unit	Reference
	HART	Display	HART	Display				
5-1	Device root menu ▶ Detailed setup ▶ Pulse/Status ▶ Pulse/Status output1 ▶ ▶ Pulse1 output mode	Device setup ▶ Detailed setup ▶ Pulse/Status out ▶ ▶ PO1/SO1 ▶ Output mode	No function Fixed pulse output Frequency output Status output	No function Fixed pulse output Frequency output Status output	RW	Fixedpulseoutput	-	P.63
5-2	Device root menu ▶ Detailed setup ▶ Pulse/Status ▶ Pulse/Status output1 ▶ ▶ Pulse1 active mode	Device setup ▶ Detailed setup ▶ Pulse/Status out ▶ ▶ PO1/SO1 ▶ Active mode	On active Off active	On active Off active	RW	On active	-	P.66
5-3	Device root menu ▶ Detailed setup ▶ Pulse/Status ▶ Pulse/Status output1 ▶ ▶ Pulse1 fix width	Device setup ▶ Detailed setup ▶ Pulse/Status out ▶ ▶ PO1/SO1 ▶ Fix width	0.05 ms 0.1 ms 0.5 ms 1 ms 20 ms 33 ms 50 ms 100 ms 200 ms 330 ms 500 ms 1000 ms 2000 ms Duty cycle 50%	0.05 ms 0.1 ms 0.5 ms 1 ms 20 ms 33 ms 50 ms 100 ms 200 ms 330 ms 500 ms 1000 ms 2000 ms Duty cycle 50%	RW	Duty cycle 50% **3	-	P.65
5-4	Device root menu ▶ Detailed setup ▶ Pulse/Status ▶ Pulse/Status output1 ▶ ▶ Pulse1 rate unit	Device setup ▶ Detailed setup ▶ Pulse/Status out ▶ ▶ PO1/SO1 ▶ Rate unit	n unit/P u unit/P m unit/P Unit/P k unit/P M unit/P n P/unit u P/unit m P/unit P/unit k P/unit M P/unit	n unit/P u unit/P m unit/P Unit/P k unit/P M unit/P n P/unit u P/unit m P/unit P/unit k P/unit M P/unit	RW	Unit/P *1	-	P.68
5-5	Device root menu ▶ Detailed setup ▶ Pulse/Status ▶ Pulse/Status output1 ▶ ▶ Pulse1 rate value	Device setup ▶ Detailed setup ▶ Pulse/Status out ▶ ▶ PO1/SO1 ▶ Rate value	0.00000 to +INF*2 Number of decimal places: 0 to 5	0.00000 to +999999 Number of decimal places: 0 to 5	RW	0.0 *1	No.5-4	P.67
5-6	Device root menu ▶ Detailed setup ▶ Pulse/Status ▶ Pulse/Status output1 ▶ ▶ Pulse1 low cut	Device setup ▶ Detailed setup ▶ Pulse/Status out ▶ PO1/SO1 ▶ Low cut	0.00000 to +INF*2 Number of decimal places: 0 to 5	0.00000 to +999999 Number of decimal places: 0 to 5	RW	0.0 *1	Flow velocity No.3-15 Volumetric flow rate: No.3-16/ No.3-19 Mass flow rate: No.3-17/ No.3-19 Flow noise cm/s	P.47
5-7	Device root menu ▶ Detailed setup ▶ Pulse/Status ▶ Pulse/Status output1 ▶ ▶ Pulse1 alarm out	Device setup ▶ Detailed setup ▶ Pulse/Status out ▶ ▶ PO1/SO1 ▶ Alarm out	0 pps Measured value Last valid Max pps	0 pps Measured value Last valid Max pps	RW	0 pps	-	P.64
5-8	Device root menu ▶ Detailed setup ▶ Pulse/Status ▶ Pulse/Status output1 ▶ ▶ Frequency1 at 0%	Device setup ▶ Detailed setup ▶ Pulse/Status out ▶ ▶ PO1/SO1 ▶ Frequency at 0%	0 to 12500 Number of decimal places: 0	0 to 12500 Number of decimal places: 0	RW	0	Hz	P.69
5-9	Device root menu ▶ Detailed setup ▶ Pulse/Status ▶ Pulse/Status output1 ▶ ▶ Frequency1 at 100%	Device setup ▶ Detailed setup ▶ Pulse/Status out ▶ ▶ PO1/SO1 ▶ Frequency at 100%	0 to 12500 Number of decimal places: 0	0 to 12500 Number of decimal places: 0	RW	0	Hz	P.69

\*1: Determined based on the information about specified items at the time of ordering and the sensor to be combined with.

\*2: The range of single precision float (IEEE 754).

\*3: When Main soft rev (Main board revision/Main soft rev) is R2.01.01 or earlier, the default value is 0.05 ms.

No.	Parameter Name		Data Range		RW	Default Value	Unit	Reference
	HART	Display	HART	Display				
5-10	Device root menu ▶ Detailed setup ▶ Pulse/Status ▶ Pulse/Status output1 ▶ Status output1 function	Device setup ▶ Detailed setup ▶ Pulse/Status out ▶ PO1/SO1 ▶ SO1 function	No function Alarm output Warning output Total limit 1 Total limit 2 Total limit 3 H/L alarm HH/LL alarm Fwd/Rev range Auto2 range Ext2 answer	No function Alarm output Warning output Total limit 1 Total limit 2 Total limit 3 H/L alarm HH/LL alarm Fwd/Rev range Auto 2 range Ext 2 answer	RW	No function	-	P.70
5-11	Device root menu ▶ Detailed setup ▶ Pulse/Status ▶ Pulse/Status output1 ▶ Pulse1 option	Device setup ▶ Detailed setup ▶ Pulse/Status out ▶ PO1/SO1 ▶ Options	Balanced Absolute Only positive Only negative	Balanced Absolute Only positive Only negative	RW	Only positive	-	P.73
5-12	Device root menu ▶ Detailed setup ▶ Pulse/Status ▶ Pulse/Status output2 ▶ Pulse2 active pulse	Device setup ▶ Detailed setup ▶ Pulse/Status out ▶ PO2/SO2 ▶ Active pulse	Normal For magnetic counter	Normal For magnetic counter	RW	Normal	-	P.67
5-13	Device root menu ▶ Detailed setup ▶ Pulse/Status ▶ Pulse/Status output2 ▶ Pulse2 output mode	Device setup ▶ Detailed setup ▶ Pulse/Status out ▶ PO2/SO2 ▶ Output mode	No function Fixed pulse output Frequency output Status output	No function Fixed pulse output Frequency output Status output	RW	No function	-	P.63
5-14	Device root menu ▶ Detailed setup ▶ Pulse/Status ▶ Pulse/Status output2 ▶ Pulse2 select	Device setup ▶ Detailed setup ▶ Pulse/Status out ▶ PO2/SO2 ▶ Pulse select	Non-Connect Velocity Volume flow Mass flow Calorie <sup>(5)</sup> Diag <sup>(5)</sup>	No connect Velocity Volume flow Mass flow Calorie <sup>(5)</sup> Diag <sup>(5)</sup>	RW	No connect	-	P.64
5-15	Device root menu ▶ Detailed setup ▶ Pulse/Status ▶ Pulse/Status output2 ▶ Pulse2 active mode	Device setup ▶ Detailed setup ▶ Pulse/Status out ▶ PO2/SO2 ▶ Active mode	On active Off active	On active Off active	RW	On active	-	P.66
5-16	Device root menu ▶ Detailed setup ▶ Pulse/Status ▶ Pulse/Status output2 ▶ Pulse2 fix width	Device setup ▶ Detailed setup ▶ Pulse/Status out ▶ PO2/SO2 ▶ Fix width	0.05 ms 0.1 ms 0.5 ms 1 ms 20 ms 33 ms 50 ms 100 ms 200 ms 330 ms 500 ms 1000 ms 2000 ms Duty cycle 50%	0.05 ms 0.1 ms 0.5 ms 1 ms 20 ms 33 ms 50 ms 100 ms 200 ms 330 ms 500 ms 1000 ms 2000 ms Duty cycle 50%	RW	Duty cycle 50% <sup>3</sup>	-	P.65
5-17	Device root menu ▶ Detailed setup ▶ Pulse/Status ▶ Pulse/Status output2 ▶ Pulse2 rate unit	Device setup ▶ Detailed setup ▶ Pulse/Status out ▶ PO2/SO2 ▶ Rate unit	n unit/P u unit/P m unit/P Unit/P k unit/P M unit/P n P/unit u P/unit m P/unit P/unit k P/unit M P/unit	n unit/P u unit/P m unit/P Unit/P k unit/P M unit/P n P/unit u P/unit m P/unit P/unit k P/unit M P/unit	RW	Unit/P	-	P.68
5-18	Device root menu ▶ Detailed setup ▶ Pulse/Status ▶ Pulse/Status output2 ▶ Pulse2 rate value	Device setup ▶ Detailed setup ▶ Pulse/Status out ▶ PO2/SO2 ▶ Rate value	0.00000 to +INF <sup>2</sup> Number of decimal places: 0 to 5	0.00000 to +999999 Number of decimal places: 0 to 5	RW	0.0	No.5-16	P.67

\*1: Determined based on the information about specified items at the time of ordering and the sensor to be combined with.

\*2: The range of single precision float (IEEE 754).

\*3: When Main soft rev (Main board revision/Main soft rev) is R2.01.01 or earlier, the default value is 0.05 ms.

No.	Parameter Name		Data Range		RW	Default Value	Unit	Reference
	HART	Display	HART	Display				
5-19	Device root menu ▶ Detailed setup ▶ Pulse/Status ▶ Pulse/Status output2 ▶ Pulse2 low cut	Device setup ▶ Detailed setup ▶ Pulse/Status out ▶ PO2/SO2 ▶ Low cut	0.00000 to +INF <sup>*2</sup> Number of decimal places: 0 to 5	0.00000 to +999999 Number of decimal places: 0 to 5	RW	0.0	Flow velocity No.3-15 Volumetric flow rate: No.3-16/ No.3-19 Mass flow rate: No.3-17/ No.3-19 Flow noise cm/s	P.47
5-20	Device root menu ▶ Detailed setup ▶ Pulse/Status ▶ Pulse/Status output2 ▶ Pulse2 alarm out	Device setup ▶ Detailed setup ▶ Pulse/Status out ▶ PO2/SO2 ▶ Alarm out	0 pps Measured value Last valid Max pps	0 pps Measured value Last valid Max pps	RW	0 pps	-	P.64
5-21	Device root menu ▶ Detailed setup ▶ Pulse/Status ▶ Pulse/Status output2 ▶ Frequency2 at 0%	Device setup ▶ Detailed setup ▶ Pulse/Status out ▶ PO2/SO2 ▶ Frequency at 0%	0 to 12500 Number of decimal places: 0	0 to 12500 Number of decimal places: 0	RW	0	Hz	P.69
5-22	Device root menu ▶ Detailed setup ▶ Pulse/Status ▶ Pulse/Status output2 ▶ Frequency2 at 100%	Device setup ▶ Detailed setup ▶ Pulse/Status out ▶ PO2/SO2 ▶ Frequency at 100%	0 to 12500 Number of decimal places: 0	0 to 12500 Number of decimal places: 0	RW	0	Hz	P.69
5-23	Device root menu ▶ Detailed setup ▶ Pulse/Status ▶ Pulse/Status output2 ▶ Status output2 function	Device setup ▶ Detailed setup ▶ Pulse/Status out ▶ PO2/SO2 ▶ SO2 function	No function Alarm output Warning output Total limit 1 Total limit 2 Total limit 3 H/L alarm HH/LL alarm Fwd/Rev range Auto2 range Ext2 answer System alarm Process alarm Setting alarm 50:Sig overflow 51:Empty detect 53:Adh over lv4 85:Cable miscon 86:Coil insulate 87:Adh over lv3 88:LC warn 89:Insu detect 90:FLN over lv3 91:FLN over lv4 93:Verif warn 94:FC noise warn Lo alarm Lo Lo alarm Hi alarm Hi Hi alarm	No function Alarm output Warning output Total limit 1 Total limit 2 Total limit 3 H/L alarm HH/LL alarm Fwd/Rev range Auto 2 range Ext 2 answer System alarm Process alarm Setting alarm Signal overflow Empty detect Adh over lv 4 Cable miscon Coil insulation Adhesion lv 3 LC warn Insu detect FLN over lv 3 FLN over lv 4 Verif warn Fact noise warn Low alarm LL alarm High alarm HH alarm	RW	No function	-	P.70
5-24	Device root menu ▶ Detailed setup ▶ Pulse/Status ▶ Pulse/Status output2 ▶ Pulse2 option	Device setup ▶ Detailed setup ▶ Pulse/Status out ▶ PO2/SO2 ▶ Options	Balanced Absolute Only positive Only negative	Balanced Absolute Only positive Only negative	RW	Only positive	-	P.73

\*1: Determined based on the information about specified items at the time of ordering and the sensor to be combined with.

\*2: The range of single precision float (IEEE 754).

\*3: When Main soft rev (Main board revision/Main soft rev) is R2.01.01 or earlier, the default value is 0.05 ms.



# 5.6 Status Input and Output Configuration Parameters

These parameters are related to the status input, status output and multi range.

No.	Parameter Name		Data Range		RW	Default Value	Unit	Reference
	HART	Display	HART	Display				
6-1	Device root menu ▶ Detailed setup ▶ Pulse/Status ▶ Status output3 ▶ Status output3 active mode	Device setup ▶ Detailed setup ▶ Pulse/Status out ▶ SO3 ▶ Active mode	On active Off active	On active Off active	RW	On active	-	P.66
6-2	Device root menu ▶ Detailed setup ▶ Pulse/Status ▶ Status output3 ▶ Status output3 function	Device setup ▶ Detailed setup ▶ Pulse/Status out ▶ SO3 ▶ Function	No function Alarm output Warning output Total limit 1 Total limit 2 Total limit 3 H/L alarm HH/LL alarm Fwd/Rev range Auto2 range Ext2 answer System alarm Process alarm Setting alarm 50:Sig overflow 51:Empty detect 53:Adh over lv4 85:Cable miscon 86:Coil insulate 87:Adh over lv3 88:LC warn 89:Insu detect 90:FLN over lv3 91:FLN over lv4 93:Verif warn 94:FC noise warn Lo alarm Lo Lo alarm Hi alarm Hi Hi alarm	No function Alarm output Warning output Total limit 1 Total limit 2 Total limit 3 H/L alarm HH/LL alarm Fwd/Rev range Auto 2 range Ext 2 answer System alarm Process alarm Setting alarm Signal overflow Empty detect Adh over lv 4 Cable miscon Coil insulation Adhesion lv 3 LC warn Insu detect FLN over lv 3 FLN over lv 4 Verif warn Fact noise warn Low alarm LL alarm High alarm HH alarm	RW	No function	-	P.70
6-3	Device root menu ▶ Detailed setup ▶ Pulse/Status ▶ Status input3 ▶ Status input3 active mode	Device setup ▶ Detailed setup ▶ Status in ▶ SI3 ▶ Active mode	Short(On) active Open(Off) active	Short(On) act Open(Off) act	RW	Short(On) act	-	P.74
6-4	Device root menu ▶ Detailed setup ▶ Pulse/Status ▶ Status input3 ▶ Status input3 function	Device setup ▶ Detailed setup ▶ Status in ▶ SI3 ▶ Function	No function 0% Signal Lock Ext auto zero Total preset 1 Total preset 2 Total preset 3 Ext2 ranges 0% Signal Lock 2	No function 0% signal lock Ext auto zero Total preset 1 Total preset 2 Total preset 3 Ext 2 ranges 0% signal lock 2	RW		-	P.75
6-5	Device root menu ▶ Detailed setup ▶ Pulse/Status ▶ Status input3 ▶ Status input3 State	Device setup ▶ Detailed setup ▶ Status in ▶ SI3 ▶ State	Open Short	Open Short	R	-	-	-
6-6	Device root menu ▶ Detailed setup ▶ Multi range ▶ Forward span 2	Device setup ▶ Detailed setup ▶ Multi range ▶ Forward span 2	0.00001 to +INF <sup>2</sup> Number of decimal places: 0 to 5	0.00001 to +999999 Number of decimal places: 0 to 5	RW	1.0	Flow velocity No.3-15 Volumetric flow rate: No.3-16/ No.3-19 Mass flow rate: No.3-17/ No.3-19 Flow noise cm/s	P.83

\*2: The range of single precision float (IEEE 754).

No.	Parameter Name		Data Range		RW	Default Value	Unit	Reference
	HART	Display	HART	Display				
6-7	Device root menu ► Detailed setup ► Multi range ► Reverse span 1	Device setup ► Detailed setup ► Multi range ► Reverse span 1	0.00001 to +INF <sup>*2</sup> Number of decimal places: 0 to 5	0.00001 to +999999 Number of decimal places: 0 to 5	RW	1.0	Flow velocity No.3-15 Volumetric flow rate: No.3-16/ No.3-19 Mass flow rate: No.3-17/ No.3-19 Flow noise cm/s	P.83
6-8	Device root menu ► Detailed setup ► Multi range ► Reverse span 2	Device setup ► Detailed setup ► Multi range ► Reverse span 2	0.00001 to +INF <sup>*2</sup> Number of decimal places: 0 to 5	0.00001 to +999999 Number of decimal places: 0 to 5	RW	1.0	Flow velocity No.3-15 Volumetric flow rate: No.3-16/ No.3-19 Mass flow rate: No.3-17/ No.3-19 Flow noise cm/s	P.83
6-9	Device root menu ► Detailed setup ► Multi range ► Auto range hyst	Device setup ► Detailed setup ► Multi range ► Auto range hyst	0 to 15 Number of decimal places: 0	0 to 15 Number of decimal places: 0	RW	10	%	P.84
6-10	Device root menu ► Detailed setup ► Multi range ► Bi direction hyst	Device setup ► Detailed setup ► Multi range ► Bi direction hyst	0 to 8 Number of decimal places: 0	0 to 8 Number of decimal places: 0	RW	2	%	P.86

\*2: The range of single precision float (IEEE 754).

# 5.7 Analog Output/Input Configuration Parameters

These parameters are related to analog output 1/2 and analog input.

No.	Parameter Name		Data Range		RW	Default Value	Unit	Reference
	HART	Display	HART	Display				
7-1	Device root menu ► Detailed setup ► Analog output/input ► ► Analog output1 ► AO1 low cut	Device setup ► Detailed setup ► Analog out/in ► AO1 ► ► Low cut	0.00000 to +INF <sup>*2</sup> Number of decimal places: 0 to 5	0.00000 to +999999 Number of decimal places: 0 to 5	RW	0.0	Flow velocity No.3-15 Volumetric flow rate: No.3-16/ No.3-19 Mass flow rate: No.3-17/ No.3-19 Flow noise cm/s	P.46
7-2	Device root menu ► Detailed setup ► Analog output/input ► ► Analog output1 ► AO1 high limit	Device setup ► Detailed setup ► Analog out/in ► AO1 ► ► High limit	+4.000 to +21.600 Number of decimal places: 3	+4.000 to +21.600 Number of decimal places: 3	RW	20.500	mA	P.77
7-3	Device root menu ► Detailed setup ► Analog output/input ► ► Analog output1 ► AO1 low limit	Device setup ► Detailed setup ► Analog out/in ► AO1 ► ► Low limit	+2.400 to +20.000 Number of decimal places: 3	+2.400 to +20.000 Number of decimal places: 3	RW	3.800	mA	P.77
7-4	Device root menu ► Detailed setup ► Analog output/input ► ► Analog output1 ► AO1 alarm out	Device setup ► Detailed setup ► Analog out/in ► AO1 ► ► Alarm out	< 2.4 mA 3.8 mA 4 mA 20.5 mA > 21.6 mA Measured value Hold	< 2.4 mA 3.8 mA 4 mA 20.5 mA > 21.6 mA Measured value Hold	RW	> 21.6 mA <sup>*1</sup>	-	P.79
7-5	Device root menu ► Detailed setup ► Analog output/input ► ► Analog output1 ► AO1 range mode	Device setup ► Detailed setup ► Analog out/in ► AO1 ► ► Range mode	Normal range Abs range	Normal range Abs range	RW	Normal range	-	P.78
7-6 (G)	Device root menu ► Detailed setup ► Analog output/input ► ► Analog output2 ► AO2 select	Device setup ► Detailed setup ► Analog out/in ► AO2 ► ► AO2 select	Non-Connect Velocity Volume flow Mass flow Calorie Diag	No connect Velocity Volume flow Mass flow Calorie Diag	RW	No connect	-	P.76
7-7 (G)	Device root menu ► Detailed setup ► Analog output/input ► ► Analog output2 ► AO2 low cut	Device setup ► Detailed setup ► Analog out/in ► AO2 ► ► Low cut	0.00000 to +INF <sup>*2</sup> Number of decimal places: 0 to 5	0.00000 to +999999 Number of decimal places: 0 to 5	RW	0.0	No.7-6	P.46
7-8 (G)	Device root menu ► Detailed setup ► Analog output/input ► ► Analog output2 ► AO2 high limit	Device setup ► Detailed setup ► Analog out/in ► AO2 ► ► High limit	+4.000 to +21.600 Number of decimal places: 3	+4.000 to +21.600 Number of decimal places: 3	RW	20.500	mA	P.77
7-9 (G)	Device root menu ► Detailed setup ► Analog output/input ► ► Analog output2 ► AO2 low limit	Device setup ► Detailed setup ► Analog out/in ► AO2 ► ► Low limit	+2.400 to +20.000 Number of decimal places: 3	+2.400 to +20.000 Number of decimal places: 3	RW	3.800	mA	P.77
7-10 (G)	Device root menu ► Detailed setup ► Analog output/input ► ► Analog output2 ► AO2 alarm out	Device setup ► Detailed setup ► Analog out/in ► AO2 ► ► Alarm out	< 2.4 mA 3.8 mA 4 mA 20.5 mA > 21.6 mA Measured value Hold	< 2.4 mA 3.8 mA 4 mA 20.5 mA > 21.6 mA Measured value Hold	RW	> 21.6 mA	-	P.79
7-11 (G)	Device root menu ► Detailed setup ► Analog output/ input ► Analog input ► AI function	Device setup ► Detailed setup ► Analog out/in ► AI ► Function	No function Monitoring Diff temperature Ext temperature	No function Monitoring Diff temperature Ext temperature	RW	No function	-	P.81
7-12 (G)	Device root menu ► Detailed setup ► Analog output/input ► ► Analog input ► AI high limit	Device setup ► Detailed setup ► Analog out/in ► AI ► High limit	+4.000 to +21.600 Number of decimal places: 3	+4.000 to +21.600 Number of decimal places: 3	RW	20.500	mA	P.82

\*1: Determined based on the information about specified items at the time of ordering and the sensor to be combined with.

\*2: The range of single precision float (IEEE 754).

No.	Parameter Name		Data Range		RW	Default Value	Unit	Reference
	HART	Display	HART	Display				
7-13 (G)	Device root menu ▶ Detailed setup ▶ Analog output/input ▶ Analog input ▶ AI low limit	Device setup ▶ Detailed setup ▶ Analog out/in ▶ AI ▶ Low limit	+2.400 to +20.000 Number of decimal places: 3	+2.400 to +20.000 Number of decimal places: 3	RW	3.800	mA	P.82
7-14 (G)	Device root menu ▶ Detailed setup ▶ Analog output/ input ▶ Analog input ▶ AI current	Device setup ▶ Detailed setup ▶ Analog out/in ▶ AI ▶ Value	0.000 to +22.730 Number of decimal places: 3	0.000 to +22.730 Number of decimal places: 3	R	0.000	mA	P.81
7-15 (G)	Device root menu ▶ Detailed setup ▶ Analog output/input ▶ Analog input ▶ AI unit	Device setup ▶ Detailed setup ▶ Analog out/in ▶ AI ▶ Unit	deg C deg F K	°C °F K	RW	deg C/°C	-	P.81
7-16 (G)	Device root menu ▶ Detailed setup ▶ Analog output/input ▶ Analog input ▶ AI URV	Device setup ▶ Detailed setup ▶ Analog out/in ▶ AI ▶ URV	-999.9 to +999.9 Number of decimal places: 1	-999.9 to +999.9 Number of decimal places: 1	RW	120.0	No.7-15	P.82
7-17 (G)	Device root menu ▶ Detailed setup ▶ Analog output/input ▶ Analog input ▶ AI LRV	Device setup ▶ Detailed setup ▶ Analog out/in ▶ AI ▶ LRV	-999.9 to +999.9 Number of decimal places: 1	-999.9 to +999.9 Number of decimal places: 1	RW	0.0	No.7-15	P.82
7-18	Maintenance root menu ▶ AO/AI trim ▶ AO trim ▶ Clear D/A trim 1	Device setup ▶ Diag/Service ▶ AO/AI trim ▶ AO trim ▶ AO1 trim clear	Not execute Execute	Not execute Execute	RW	Not execute	-	P.80
7-19	Maintenance root menu ▶ AO/AI trim ▶ AO trim ▶ AO1 trim	Device setup ▶ Diag/Service ▶ AO/AI trim ▶ AO trim ▶ AO1 trim 4mA	3.200 to 5.600 Number of decimal places: 3	3.200 to 5.600 Number of decimal places: 3	RW	4.000	mA	P.80
7-20		Device setup ▶ Diag/Service ▶ AO/AI trim ▶ AO trim ▶ AO1 trim 20mA	18.400 to 21.600 Number of decimal places: 3	18.400 to 21.600 Number of decimal places: 3	RW	20.000	mA	P.80
7-21 (G)	Maintenance root menu ▶ AO/AI trim ▶ AO trim ▶ Clear D/A trim 2	Device setup ▶ Diag/Service ▶ AO/AI trim ▶ AO trim ▶ AO2 trim clear	Not execute Execute	Not execute Execute	RW	Not execute	-	P.80
7-22 (G)	Maintenance root menu ▶ AO/AI trim ▶ AO trim ▶ AO2 trim	Device setup ▶ Diag/Service ▶ AO/AI trim ▶ AO trim ▶ AO2 trim 4mA	3.200 to 5.600 Number of decimal places: 3	3.200 to 5.600 Number of decimal places: 3	RW	4.000	mA	P.80
7-23 (G)		Device setup ▶ Diag/Service ▶ AO/AI trim ▶ AO trim ▶ AO2 trim 20mA	18.400 to 21.600 Number of decimal places: 3	18.400 to 21.600 Number of decimal places: 3	RW	20.000	mA	P.80
7-24 (G)	Maintenance root menu ▶ AO/AI trim ▶ AI trim ▶ Clear AI trim	Device setup ▶ Diag/Service ▶ AO/AI trim ▶ AI trim ▶ Trim clear	Not execute Execute	Not execute Execute	RW	Not execute	-	P.80
7-25 (G)	Maintenance root menu ▶ AO/AI trim ▶ AI trim ▶ AI trim	Device setup ▶ Diag/Service ▶ AO/AI trim ▶ AI trim ▶ Trim 4mA	3.200 to 5.600 Number of decimal places: 3	3.200 to 5.600 Number of decimal places: 3	RW	4.000	mA	P.80
7-26 (G)		Device setup ▶ Diag/Service ▶ AO/AI trim ▶ AI trim ▶ Trim 20mA	18.400 to 21.600 Number of decimal places: 3	18.400 to 21.600 Number of decimal places: 3	RW	20.000	mA	P.80

\*1: Determined based on the information about specified items at the time of ordering and the sensor to be combined with.

\*2: The range of single precision float (IEEE 754).

# 5.8 Auxiliary Function Configuration Parameters

These parameters are related to the flow direction, rate limit, low cut, temperature correction for density, or calorie calculation.

No.	Parameter Name		Data Range		R/W	Default Value	Unit	Reference
	HART	Display	HART	Display				
8-1	Device root menu ▶ Detailed setup ▶ AUX calculation ▶ Flow direction	Device setup ▶ Detailed setup ▶ AUX calculation ▶ Flow direct	Forward Reverse	Forward Reverse	RW	Forward	-	P.92
8-2	Device root menu ▶ Detailed setup ▶ AUX calculation ▶ Rate limit	Device setup ▶ Detailed setup ▶ AUX calculation ▶ Rate limit	0.0 to 10.0 Number of decimal places: 1	0.0 to 10.0 Number of decimal places: 1	RW	5.0	%	P.92
8-3	Device root menu ▶ Detailed setup ▶ AUX calculation ▶ Dead time	Device setup ▶ Detailed setup ▶ AUX calculation ▶ Dead time	0.0 to 15.0 Number of decimal places: 1	0.0 to 15.0 Number of decimal places: 1	RW	0.0	s	P.92
8-4	Device root menu ▶ Detailed setup ▶ AUX calculation ▶ Noise filter	Device setup ▶ Detailed setup ▶ AUX calculation ▶ Noise filter	Manual Level1 Level2 Level3	Manual Level 1 Level 2 Level 3	RW	Manual	-	P.92
8-5	Device root menu ▶ Detailed setup ▶ AUX calculation ▶ Pulsing flow	Device setup ▶ Detailed setup ▶ AUX calculation ▶ Pulsing flow	No Yes	No Yes	RW	No	-	P.95
8-6	Device root menu ▶ Detailed setup ▶ AUX calculation ▶ Power synchronize	Device setup ▶ Detailed setup ▶ AUX calculation ▶ Power sync	No Yes	No Yes	RW	Yes	-	P.95
8-7	Device root menu ▶ Detailed setup ▶ AUX calculation ▶ Set power frequency	Device setup ▶ Detailed setup ▶ AUX calculation ▶ Set power freq	47.00 to 63.00 Number of decimal places: 2	47.00 to 63.00 Number of decimal places: 2	RW	50.00	Hz	P.95
8-8	Device root menu ▶ Detailed setup ▶ AUX calculation ▶ IEX power frequency	Device setup ▶ Detailed setup ▶ AUX calculation ▶ IEX power frequency	0.00 to 99.99 Number of decimal places: 2	0.00 to 99.99 Number of decimal places: 2	R	-	Hz	P.95
8-9	Device root menu ▶ Detailed setup ▶ AUX calculation ▶ Measured power frequency	Device setup ▶ Detailed setup ▶ AUX calculation ▶ Meas power freq	0.00 to 99.99 Number of decimal places: 2	0.00 to 99.99 Number of decimal places: 2	R	-	Hz	P.95
8-10 (G)	Device root menu ▶ Detailed setup ▶ Process variables ▶ Density ▶ Density value select	Device setup ▶ Detailed setup ▶ Pro var ▶ Density ▶ Value select	Fixed value Correction value	Fixed value Correction value	RW	Fixed value	-	P.51
8-11	Device root menu ▶ Detailed setup ▶ Process variables ▶ Density ▶ Density unit	Device setup ▶ Detailed setup ▶ Pro var ▶ Density ▶ Unit	kg/m <sup>3</sup> lb/gal lb/cf	kg/m <sup>3</sup> lb/gal lb/cf	RW	kg/m <sup>3</sup>	-	P.51
8-12	Device root menu ▶ Detailed setup ▶ Process variables ▶ Density ▶ Density fixed value	Device setup ▶ Detailed setup ▶ Pro var ▶ Density ▶ Fixed density	0.00000 to 999999 Number of decimal places: 0 to 5	0.00000 to 999999 Number of decimal places: 0 to 5	RW	0 <sup>*1</sup>	No.8-11	P.51
8-13 (G)	Device root menu ▶ Detailed setup ▶ Process variables ▶ Density ▶ Standard density	Device setup ▶ Detailed setup ▶ Pro var ▶ Density ▶ Std density	0.00000 to +999999 Number of decimal places: 0 to 5	0.00000 to +999999 Number of decimal places: 0 to 5	RW	0	No.8-11	P.51
8-14 (G)	Device root menu ▶ Detailed setup ▶ Process variables ▶ Temperature ▶ Standard temperature	Device setup ▶ Detailed setup ▶ Pro var ▶ Temperature ▶ Std temperature	-999.99 to +999.99 Number of decimal places: 2	-999.99 to +999.99 Number of decimal places: 2	RW	20.00	No.7-15	P.52
8-15 (G)	Device root menu ▶ Detailed setup ▶ Process variables ▶ Temperature ▶ Temp coef A1	Device setup ▶ Detailed setup ▶ Pro var ▶ Temperature ▶ Coef A1	-INF <sup>*2</sup> to +INF <sup>*2</sup> Number of decimal places: 0 to 5 -32000.0 to +32000.0	-999999 to +999999 Number of decimal places: 0 to 5 -32000.0 to +32000.0	RW	0.0	-	P.96

\*1: Determined based on the information about specified items at the time of ordering and the sensor to be combined with.

\*2: The range of single precision float (IEEE 754).

No.	Parameter Name		Data Range		RW	Default Value	Unit	Reference
	HART	Display	HART	Display				
8-16 (G)	Device root menu ▶ Detailed setup ▶ Process variables ▶ Temperature ▶ Temp coef A2	Device setup ▶ Detailed setup ▶ Pro var ▶ Temperature ▶ Coef A2	-INF <sup>2</sup> to +INF <sup>2</sup> Number of decimal places: 0 to 5 -32000.0 to +32000.0	-999999 to +999999 Number of decimal places: 0 to 5 -32000.0 to +32000.0	RW	0.0	-	P.96
8-17 (G)	Device root menu ▶ Detailed setup ▶ Process variables ▶ Temperature ▶ Measured temperature	Device setup ▶ Detailed setup ▶ Pro var ▶ Temperature ▶ Meas temperature	-999.99 to +999.99 Number of decimal places: 2	-999.99 to +999.99 Number of decimal places: 2	R	-	No.7-15	P.52
8-18 (G)	Device root menu ▶ Detailed setup ▶ Process variables ▶ Density ▶ Correct density	Device setup ▶ Detailed setup ▶ Pro var ▶ Density ▶ Correct density	0.0 to 999999 Number of decimal places: 0 to 5	0.0 to 999999 Number of decimal places: 0 to 5	R	-	No.8-11	P.51
8-19 (G)	Device root menu ▶ Detailed setup ▶ Process variables ▶ Calorie ▶ Specific heat	Device setup ▶ Detailed setup ▶ Pro var ▶ Calorie ▶ Specific heat	0.0 to +99999.9 Number of decimal places: 1	0.0 to +99999.9 Number of decimal places: 1	RW	4184.0	J/kg*K	P.98
8-20 (G)	Device root menu ▶ Detailed setup ▶ Process variables ▶ Temperature ▶ Calorific fix temp	Device setup ▶ Detailed setup ▶ Pro var ▶ Temperature ▶ Fixed temperature	-999.99 to +999.99 Number of decimal places: 2	-999.99 to +999.99 Number of decimal places: 2	RW	20.00	No.7-15	P.52
8-21 (G)	Process variables root menu ▶ Device variables ▶ Calorific value	Device setup ▶ Process variables ▶ Calorie	-INF <sup>2</sup> to +INF <sup>2</sup> Number of decimal places: 0 to 5	-999999 to +999999 Number of decimal places: 0 to 5	R	-	No.3-18/ No.3-19	P.42
8-22	Device root menu ▶ Detailed setup ▶ AUX calculation ▶ Set SIL	Device setup ▶ Detailed setup ▶ AUX calculation ▶ Set SIL	No Yes	No Yes	RW	No	-	P.99

\*1: Determined based on the information about specified items at the time of ordering and the sensor to be combined with.

\*2: The range of single precision float (IEEE 754).

# 5.9 Alarm Configuration Parameters

These parameters are related to the alarm output, burnout and history.

No.	Parameter Name		Data Range		R/W	Default Value	Unit	Reference
	HART	Display	HART	Display				
9-1	Maintenance root menu ► High/Low alarm configuration ► High alarm	Device setup ► Diag/Service ► H/L alarm cfg ► High alarm	-INF <sup>2</sup> to +INF <sup>2</sup> Number of decimal places: 0 to 5	-999999 to +999999 Number of decimal places: 0 to 5	RW	300.000	Flow velocity No.3-15 Volumetric flow rate: No.3-16/ No.3-19 Mass flow rate: No.3-17/ No.3-19 Flow noise cm/s	P.137
9-2	Maintenance root menu ► High/Low alarm configuration ► Low alarm	Device setup ► Diag/Service ► H/L alarm cfg ► Low alarm	-INF <sup>2</sup> to +INF <sup>2</sup> Number of decimal places: 0 to 5	-999999 to +999999 Number of decimal places: 0 to 5	RW	-300.000	Flow velocity No.3-15 Volumetric flow rate: No.3-16/ No.3-19 Mass flow rate: No.3-17/ No.3-19 Flow noise cm/s	P.137
9-3	Maintenance root menu ► High/Low alarm configuration ► High high alarm	Device setup ► Diag/Service ► H/L alarm cfg ► HH alarm	-INF <sup>2</sup> to +INF <sup>2</sup> Number of decimal places: 0 to 5	-999999 to +999999 Number of decimal places: 0 to 5	RW	300.000	Flow velocity No.3-15 Volumetric flow rate: No.3-16/ No.3-19 Mass flow rate: No.3-17/ No.3-19 Flow noise cm/s	P.137
9-4	Maintenance root menu ► High/Low alarm configuration ► Low low alarm	Device setup ► Diag/Service ► H/L alarm cfg ► LL alarm	-INF <sup>2</sup> to +INF <sup>2</sup> Number of decimal places: 0 to 5	-999999 to +999999 Number of decimal places: 0 to 5	RW	-300.000	Flow velocity No.3-15 Volumetric flow rate: No.3-16/ No.3-19 Mass flow rate: No.3-17/ No.3-19 Flow noise cm/s	P.137
9-5	Maintenance root menu ► High/Low alarm configuration ► Hi/Lo alarm hysteresis	Device setup ► Diag/Service ► H/L alarm cfg ► H/L alarm hyst	0 to 10 Number of decimal places: 0	0 to 10 Number of decimal places: 0	RW	5	%	P.137
9-6	Diagnostic root menu ► Status/Self test ► Burn out	Device setup ► Diag/Service ► H/L alarm cfg ► 4-20 burnout	High Low	High Low	R	-	-	P.119
9-7	Diagnostic root menu ► Status/Self test ► Alarm ► Alarm out mask ► Alarm out mask 1	Device setup ► Diag/Service ► Sts/Self test ► Alarm ► Alarm out mask ► Mask 1-1	13: Main board EEPROM default on	013:Main EEP dflt	RW	All Off	-	P.112
		Device setup ► Diag/Service ► Sts/Self test ► Alarm ► Alarm out mask ► Mask 1-2	21: PWM1 stop on 22: PWM2 stop on 23: Option board mismatch on 24: Option EEPROM failure on 25: Option board A/D failure on 26: Option board SPI failure on 28: Indicator board failure on 29: Ind EEP FAIL on 30: LCD driver failure on 31: Indicator board mismatch on 32: Indicator communication error on 33: microSD failure on	021:PWM 1 stop 022:PWM 2 stop 023:Opt bd mismatch 024:Opt bd EEP FAIL 025:Opt bd A/D FAIL 026:Opt bd SPI FAIL 028:Ind bd FAIL 029:Ind bd EEP FAIL 030:LCD drv FAIL 031:Ind bd mismatch 032:Ind comm ERR 033:microSD FAIL	RW	028:Ind bd FAIL	-	P.112

\*2: The range of single precision float (IEEE 754).

No.	Parameter Name		Data Range		R/W	Default Value	Unit	Reference
	HART	Display	HART	Display				
9-7	Diagnostic root menu ► Status/Self test ► Alarm ► Alarm out mask ► Alarm out mask 2	Device setup ► Diag/Service ► Sts/Self test ► Alarm ► Alarm out mask ► Mask 2-1	50: Signal overflow on 51: Empty pipe detection on 52: H/L HH/LL alarm on 53: Adhesion over level 4 on 60: Span configuration error on 61: PV flow configuration error on <sup>(G)</sup> 62: Analog output 1 4-20 mA limit error on 63: Analog output 2 4-20 mA limit error on <sup>(G)</sup> 64: Analog output 1 multi range error on 65: H/L HH/LL configuration error on 66: Density configuration error on	050: Signal overflow 051: Empty detect 052: H/L HH/LL alm 053: Adh over lv 4 060: Span cfg ERR 061: PV F cfg ERR <sup>(G)</sup> 062: AO 1 4-20 lmt 063: AO 2 4-20 lmt <sup>(G)</sup> 064: AO 1 mlt rng 065: H/L cfg ERR 066: Density cfg ERR	RW	052:H/L HH/LL alm 053:Adh over lv 4	-	P.112
		Device setup ► Diag/Service ► Sts/Self test ► Alarm ► Alarm out mask ► Mask 2-2	67: Pulse output 1 configuration error on 68: Pulse output 2 configuration error on 69: Nominal size configuration error on 70: Adhesion configuration error on 71: Flow noise config error on <sup>(G)</sup> 72: Data logging not started on 80: Analog output 1 saturated on 81: Analog output 2 saturated on <sup>(G)</sup> 82: Pulse output 1 saturated on 83: Pulse output 2 saturated on 84: Analog input saturated on <sup>(G)</sup> 85: Cable misconnect on 86: Coil insulation warning on 131: Transmitter type mismatch on	067:Pls 1 cfg ERR 068:Pls 2 cfg ERR 069:Nomi size cfg 070:Adh cfg ERR 071:FLN cfg ERR <sup>(G)</sup> 072:Log not start 080:AO 1 saturate 081:AO 2 saturate <sup>(G)</sup> 082:Pls 1 saturate 083:Pls 2 saturate 084:AI saturate <sup>(G)</sup> 085:Cable miscon 086:Coil insulation 131:Trans mismatch	RW	081:AO 2 saturate 082:Pls 1 saturate 083:Pls 2 saturate 084:AI saturate 086:Coil insulation	-	P.112
	Diagnostic root menu ► Status/Self test ► Alarm ► Alarm out mask ► Alarm out mask 3	Device setup ► Diag/Service ► Sts/Self test ► Alarm ► Alarm out mask ► Mask 3-1	87: Adhesion over level 3 on 88: Low conductivity warning on <sup>(G)</sup> 89: Insulation detection on <sup>(G)</sup> 90: Flow noise over level 3 on <sup>(G)</sup> 91: Flow noise over level 4 on <sup>(G)</sup> 92: Autozero warning on 93: Verification warning on 94: Factory noise warning on <sup>(G)</sup> 95: Simulation active on 96: Analog output 1 fixed on 97: Analog output 2 fixed on <sup>(G)</sup> 98: Pulse output 1 fixed on 99: Pulse output 2 fixed on 100: Analog input fixed on <sup>(G)</sup>	087:Adhesion lv 3 088:LC warn <sup>(G)</sup> 089:Insu detect <sup>(G)</sup> 090:FLN over lv 3 <sup>(G)</sup> 091:FLN over lv 4 <sup>(G)</sup> 092:AZ warn 093:Verif warn 094:Fact noise warn <sup>(G)</sup> 095:Simulate active 096:AO 1 fix 097:AO 2 fix <sup>(G)</sup> 098:Pls 1 fix 099:Pls 2 fix 100:AI fix <sup>(G)</sup>	RW	087:Adhesion lv 3 088:LC warn 089:Insu detect 090:FLN over lv 3 091:FLN over lv 4 093:Verif warn 094:Fact noise warn	-	P.112
		Device setup ► Diag/Service ► Sts/Self test ► Alarm ► Alarm out mask ► Mask 3-2	101: Parameter restore running on 102: Display over warning on 103: microSD card size warning on 104: Parameter backup incomplete on 105: microSD card mismatch on 106: microSD card removal error on 120: Watchdog on 121: Power off on 122: Instant power failure on 123: Parameter backup running on 124: Data logging running on	101:Param restore run 102:Disp over 103:SD size warn 104:Bkup incmplt 105:SD mismatch 106:SD removal ERR 120:Watchdog 121:Power off 122:Inst power FAIL 123:Param bkup run 124:Data log run	RW	101:Param restore run 102:Disp over 103:SD size warn 105:SD mismatch 106:SD removal ERR 120:Watchdog 121:Power off 122:Inst power FAIL 123:Param bkup run 124:Data log run	-	P.112
Diagnostic root menu ► Status/Self test ► Alarm ► Alarm out mask ► Alarm out mask 4	Device setup ► Diag/Service ► Sts/Self test ► Alarm ► Alarm out mask ► Mask 4-1	130: Device ID not entered on	130:DevID not enter	RW	All Space	-	P.112	

\*2: The range of single precision float (IEEE 754).



No.	Parameter Name		Data Range		R/W	Default Value	Unit	Reference
	HART	Display	HART	Display				
9-8	Diagnostic root menu ▶ Status/Self test ▶ Alarm ▶ Alarm record mask ▶ Alarm record mask 1	Device setup ▶ Diag/Service ▶ Sts/Self test ▶ Alarm ▶ Alarm record mask ▶ Mask 1-1	13:Main board EEPROM default on	013:Main EEP dflt	RW	All Space	-	P.112
		Device setup ▶ Diag/Service ▶ Sts/Self test ▶ Alarm ▶ Alarm record mask ▶ Mask 1-2	21:PWM1 stop on 22:PWM1 stop on 23:Option board mismatch on 24:Option EEPROM failure on 25:Option board A/D failure on 26:Option board SPI failure on 28:Indicator board failure on 29:Ind EEP FAIL on 30:LCD driver failure on 31:Indicator board mismatch on 32:Indicator communication error on 33:microSD failure on	021:PWM 1 stop 022:PWM 2 stop 023:Opt bd mismatch 024:Opt bd EEP FAIL 025:Opt bd A/D FAIL 026:Opt bd SPI FAIL 028:Ind bd FAIL 029:Ind bd EEP FAIL 030:LCD drv FAIL 031:Ind bd mismatch 032:Ind comm ERR 033:microSD FAIL	RW	All Space	-	P.112
	Diagnostic root menu ▶ Status/Self test ▶ Alarm ▶ Alarm record mask ▶ Alarm record mask 2	Device setup ▶ Diag/Service ▶ Sts/Self test ▶ Alarm ▶ Alarm record mask ▶ Mask 2-1	50: Signal overflow on 51: Empty pipe detection on 52: H/L HH/LL alarm on 53: Adhesion over level 4 on	050:Signal overflow 051:Empty detect 052:H/L HH/LL alm 053:Adh over lv 4	RW	All Space	-	P.112
		Device setup ▶ Diag/Service ▶ Sts/Self test ▶ Alarm ▶ Alarm record mask ▶ Mask 2-2	85: Cable misconnect on	085:Cable miscon	RW	All Space	-	P.112
	Diagnostic root menu ▶ Status/Self test ▶ Alarm ▶ Alarm record mask ▶ Alarm record mask 3	Device setup ▶ Diag/Service ▶ Sts/Self test ▶ Alarm ▶ Alarm record mask ▶ Mask 3-1	130: Device ID not entered on	130:DevID not enter	RW	130:DevID not enter	-	P.112
9-9	Diagnostic root menu ▶ Status/Self test ▶ Alarm ▶ Alarm record ▶ Alarm record 1	Device setup ▶ Diag/Service ▶ Sts/Self test ▶ Alarm ▶ Alarm record ▶ Record alarm 1	All Space 10: Main board CPU failure 11: Reverse calculation failure 12: Main board EEPROM failure 13: Main board EEPROM default 14: Sensor board failure 15: Sensor communication error 16: A/D1 failure[Signal] 17: A/D2 failure[Exciter] 18: Coil open 19: Coil short 20: Exciter failure 21: PWM1 stop 22: PWM2 stop 23: Option board mismatch 24: Option board EEPROM failure 25: Option board A/D failure 26: Option board SPI failure 27: Parameter restore incomplete 28: Indicator board failure 29: Indicator board EEPROM failure 30: LCD driver failure 31: Indicator board mismatch 32: Indicator communication error 33: microSD failure 50: Signal overflow 51: Empty pipe detection 52: H/L or HH/LL alarm 53: Adhesion over level 4 85: Cable misconnect 120:Watchdog on 121:Power off on 122:Instant power failure on 130:Device ID not entered	All Space 010:Main CPU FAIL 011:Rev calc FAIL 012:Main EEP FAIL 013:Main EEP dflt 014:Snsr bd FAIL 015:Snsr comm ERR 016:AD 1 FAIL[Sig] 017:AD 2 FAIL[Excit] 018:Coil open 019:Coil short 020:Exciter FAIL 021:PWM 1 stop 022:PWM 2 stop 023:Opt bd mismatch 024:Opt bd EEP FAIL 025:Opt bd A/D FAIL 026:Opt bd SPI FAIL 027:Restore FAIL 028:Ind bd FAIL 029:Ind bd EEP FAIL 030:LCD drv FAIL 031:Ind bd mismatch 032:Ind comm ERR 033:microSD FAIL 050:Signal overflow 051:Empty detect 052:H/L HH/LL alm 053:Adh over lv 4 085:Cable miscon 120:Watchdog 121:Power off 122:Inst power FAIL 130:DevID not enter	R	All Space	-	P.111
9-10	Diagnostic root menu ▶ Status/Self test ▶ Alarm ▶ Alarm record ▶ Alarm record time 1	Device setup ▶ Diag/Service ▶ Sts/Self test ▶ Alarm ▶ Alarm record ▶ Record time 1	00000D 00: 00 to 99999D 23: 59	00000D 00: 00 to 99999D 23: 59	R	00000D 00: 00	-	P.111

\*2: The range of single precision float (IEEE 754).

No.	Parameter Name		Data Range		R/W	Default Value	Unit	Reference
	HART	Display	HART	Display				
9-11	Diagnostic root menu ▶ Status/Self test ▶ Alarm ▶ Alarm record ▶ Alarm record 2	Device setup ▶ Diag/Service ▶ Sts/Self test ▶ Alarm ▶ Alarm record ▶ Record alarm 2	All Space 10: Main board CPU failure 11: Reverse calculation failure 12: Main board EEPROM failure 13: Main board EEPROM default 14: Sensor board failure 15: Sensor communication error 16: A/D1 failure[Signal] 17: A/D2 failure[Exciter] 18: Coil open 19: Coil short 20: Exciter failure 21: PWM1 stop 22: PWM2 stop 23: Option board mismatch 24: Option board EEPROM failure 25: Option board A/D failure 26: Option board SPI failure 27: Parameter restore incomplete 28: Indicator board failure 29: Indicator board EEPROM failure 30: LCD driver failure 31: Indicator board mismatch 32: Indicator communication error 33: microSD failure 50: Signal overflow 51: Empty pipe detection 52: H/L or HH/LL alarm 53: Adhesion over level 4 85: Cable misconnect 120: Watchdog on 121: Power off on 122: Instant power failure on 130: Device ID not entered	All Space 010: Main CPU FAIL 011: Rev calc FAIL 012: Main EEP FAIL 013: Main EEP dflt 014: Snsr bd FAIL 015: Snsr comm ERR 016: AD 1 FAIL[Sig] 017: AD 2 FAIL[Excit] 018: Coil open 019: Coil short 020: Exciter FAIL 021: PWM 1 stop 022: PWM 2 stop 023: Opt bd mismatch 024: Opt bd EEP FAIL 025: Opt bd A/D FAIL 026: Opt bd SPI FAIL 027: Restore FAIL 028: Ind bd FAIL 029: Ind bd EEP FAIL 030: LCD drv FAIL 031: Ind bd mismatch 032: Ind comm ERR 033: microSD FAIL 050: Signal overflow 051: Empty detect 052: H/L HH/LL alm 053: Adh over lv 4 085: Cable miscon 120: Watchdog 121: Power off 122: Inst power FAIL 130: DevID not enter	R	All Space	-	P.111
9-12	Diagnostic root menu ▶ Status/Self test ▶ Alarm ▶ Alarm record ▶ Alarm record time 2	Device setup ▶ Diag/Service ▶ Sts/Self test ▶ Alarm ▶ Alarm record ▶ Record time 2	00000D 00: 00 to 99999D 23: 59	00000D 00: 00 to 99999D 23: 59	R	00000D 00: 00	-	P.111
9-13	Diagnostic root menu ▶ Status/Self test ▶ Alarm ▶ Alarm record ▶ Alarm record 3	Device setup ▶ Diag/Service ▶ Sts/Self test ▶ Alarm ▶ Alarm record ▶ Record alarm 3	All Space 10: Main board CPU failure 11: Reverse calculation failure 12: Main board EEPROM failure 13: Main board EEPROM default 14: Sensor board failure 15: Sensor communication error 16: A/D1 failure[Signal] 17: A/D2 failure[Exciter] 18: Coil open 19: Coil short 20: Exciter failure 21: PWM1 stop 22: PWM2 stop 23: Option board mismatch 24: Option board EEPROM failure 25: Option board A/D failure 26: Option board SPI failure 27: Parameter restore incomplete 28: Indicator board failure 29: Indicator board EEPROM failure 30: LCD driver failure 31: Indicator board mismatch 32: Indicator communication error 33: microSD failure 50: Signal overflow 51: Empty pipe detection 52: H/L or HH/LL alarm 53: Adhesion over level 4 85: Cable misconnect 120: Watchdog on 121: Power off on 122: Instant power failure on 130: Device ID not entered	All Space 010: Main CPU FAIL 011: Rev calc FAIL 012: Main EEP FAIL 013: Main EEP dflt 014: Snsr bd FAIL 015: Snsr comm ERR 016: AD 1 FAIL[Sig] 017: AD 2 FAIL[Excit] 018: Coil open 019: Coil short 020: Exciter FAIL 021: PWM 1 stop 022: PWM 2 stop 023: Opt bd mismatch 024: Opt bd EEP FAIL 025: Opt bd A/D FAIL 026: Opt bd SPI FAIL 027: Restore FAIL 028: Ind bd FAIL 029: Ind bd EEP FAIL 030: LCD drv FAIL 031: Ind bd mismatch 032: Ind comm ERR 033: microSD FAIL 050: Signal overflow 051: Empty detect 052: H/L HH/LL alm 053: Adh over lv 4 085: Cable miscon 120: Watchdog 121: Power off 122: Inst power FAIL 130: DevID not enter	R	All Space	-	P.111
9-14	Diagnostic root menu ▶ Status/Self test ▶ Alarm ▶ Alarm record ▶ Alarm record time 3	Device setup ▶ Diag/Service ▶ Sts/Self test ▶ Alarm ▶ Alarm record ▶ Record time 3	00000D 00: 00 to 99999D 23: 59	00000D 00: 00 to 99999D 23: 59	R	00000D 00: 00	-	P.111

\*2: The range of single precision float (IEEE 754).

No.	Parameter Name		Data Range		R/W	Default Value	Unit	Reference
	HART	Display	HART	Display				
9-15	Diagnostic root menu ▶ Status/Self test ▶ Alarm ▶ Alarm record ▶ Alarm record 4	Device setup ▶ Diag/Service ▶ Sts/Self test ▶ Alarm ▶ Alarm record ▶ Record alarm 4	All Space 10: Main board CPU failure 11: Reverse calculation failure 12: Main board EEPROM failure 13: Main board EEPROM default 14: Sensor board failure 15: Sensor communication error 16: A/D1 failure[Signal] 17: A/D2 failure[Exciter] 18: Coil open 19: Coil short 20: Exciter failure 21: PWM1 stop 22: PWM2 stop 23: Option board mismatch 24: Option board EEPROM failure 25: Option board A/D failure 26: Option board SPI failure 27: Parameter restore incomplete 28: Indicator board failure 29: Indicator board EEPROM failure 30: LCD driver failure 31: Indicator board mismatch 32: Indicator communication error 33: microSD failure 50: Signal overflow 51: Empty pipe detection 52: H/L or HH/LL alarm 53: Adhesion over level 4 85: Cable misconnect 120: Watchdog on 121: Power off on 122: Instant power failure on 130: Device ID not entered	All Space 010: Main CPU FAIL 011: Rev calc FAIL 012: Main EEP FAIL 013: Main EEP dft 014: Snsr bd FAIL 015: Snsr comm ERR 016: AD 1 FAIL [Sig] 017: AD 2 FAIL [Excit] 018: Coil open 019: Coil short 020: Exciter FAIL 021: PWM 1 stop 022: PWM 2 stop 023: Opt bd mismatch 024: Opt bd EEP FAIL 025: Opt bd A/D FAIL 026: Opt bd SPI FAIL 027: Restore FAIL 028: Ind bd FAIL 029: Ind bd EEP FAIL 030: LCD drv FAIL 031: Ind bd mismatch 032: Ind comm ERR 033: microSD FAIL 050: Signal overflow 051: Empty detect 052: H/L HH/LL alm 053: Adh over lv 4 085: Cable miscon 120: Watchdog 121: Power off 122: Inst power FAIL 130: DevID not enter	R	All Space	-	P.111
9-16	Diagnostic root menu ▶ Status/Self test ▶ Alarm ▶ Alarm record ▶ Alarm record time 4	Device setup ▶ Diag/Service ▶ Sts/Self test ▶ Alarm ▶ Alarm record ▶ Record time 4	00000D 00: 00 to 99999D 23: 59	00000D 00: 00 to 99999D 23: 59	R	00000D 00: 00	-	P.111

\*2: The range of single precision float (IEEE 754).

# 5.10 Display Configuration Parameters

These parameters are related to display settings.

No.	Parameter Name		Data Range		RW	Default Value	Unit	Reference
	HART	Display	HART	Display				
10-1	Device root menu ▶ Detailed setup ▶ Display ▶ Line select ▶ Display select1	Device setup ▶ Detailed setup ▶ Display set ▶ Line select ▶ Line 1	Flow rate(%) PV Velocity Volume flow Mass flow Flow rate(%Bar) Calorie <sup>(G)</sup> Totalizer1 Totalizer2 Totalizer3 Tag number Long tag Commun protocol Adhesion Analog out1 Analog out2 <sup>(G)</sup> Flow noise level <sup>(G)</sup> Totalizer1 count Totalizer2 count Totalizer3 count	Flow rate(%) PV Velocity Volume flow Mass flow Flow rate(%Bar) Calorie <sup>(G)</sup> Totalizer 1 Totalizer 2 Totalizer 3 Tag number Long tag Commun protocol Adhesion Analog out 1 Analog out 2 <sup>(G)</sup> Flow noise level <sup>(G)</sup> Totalizer 1 count Totalizer 2 count Totalizer 3 count	RW	PV	-	P.121
10-2	Device root menu ▶ Detailed setup ▶ Display ▶ Line select ▶ Display select2	Device setup ▶ Detailed setup ▶ Display set ▶ Line select ▶ Line 2	None Flow rate(%) PV Velocity Volume flow	None Flow rate(%) PV Velocity Volume flow	RW	Flow rate(%)	-	P.121
10-3	Device root menu ▶ Detailed setup ▶ Display ▶ Line select ▶ Display select3	Device setup ▶ Detailed setup ▶ Display set ▶ Line select ▶ Line 3	Mass flow Flow rate(%Bar) Calorie <sup>(G)</sup> Totalizer1 Totalizer2 Totalizer3 Tag number Long tag Commun protocol Adhesion Analog out1 Analog out2 <sup>(G)</sup>	Mass flow Flow rate(%Bar) Calorie <sup>(G)</sup> Totalizer 1 Totalizer 2 Totalizer 3 Tag number Long tag Commun protocol Adhesion Analog out 1 Analog out 2 <sup>(G)</sup>	RW	Analog out 1	-	P.121
10-4	Device root menu ▶ Detailed setup ▶ Display ▶ Line select ▶ Display select4	Device setup ▶ Detailed setup ▶ Display set ▶ Line select ▶ Line 4	Totalizer1 Totalizer2 Totalizer3 Tag number Long tag Commun protocol Adhesion Analog out1 Analog out2 <sup>(G)</sup>	Totalizer 1 Totalizer 2 Totalizer 3 Tag number Long tag Commun protocol Adhesion Analog out 1 Analog out 2 <sup>(G)</sup>	RW	None	-	P.121
10-5	Device root menu ▶ Detailed setup ▶ Display ▶ Line select ▶ Display select5	Device setup ▶ Detailed setup ▶ Display set ▶ Line select ▶ Line 5	Flow noise level <sup>(G)</sup> Totalizer1 count Totalizer2 count Totalizer3 count	Flow noise level <sup>(G)</sup> Totalizer 1 count Totalizer 2 count Totalizer 3 count	RW	None	-	P.121
10-6	Device root menu ▶ Detailed setup ▶ Display ▶ Line select ▶ Display select6	Device setup ▶ Detailed setup ▶ Display set ▶ Line select ▶ Line 6	Totalizer1 count Totalizer2 count Totalizer3 count	Totalizer 1 count Totalizer 2 count Totalizer 3 count	RW	None	-	P.121
10-7	Device root menu ▶ Detailed setup ▶ Display ▶ Line select ▶ Display select7	Device setup ▶ Detailed setup ▶ Display set ▶ Line select ▶ Line 7			RW	None	-	P.121
10-8	Device root menu ▶ Detailed setup ▶ Display ▶ Line select ▶ Display select8	Device setup ▶ Detailed setup ▶ Display set ▶ Line select ▶ Line 8			RW	None	-	P.121
10-9	Device root menu ▶ Detailed setup ▶ Display ▶ Display format ▶ Display format PV	Device setup ▶ Detailed setup ▶ Display set ▶ Disp format ▶ Format PV	Auto 0 digit 1 digit 2 digit 3 digit 4 digit 5 digit Auto 2	Auto 0 digit 1 digit 2 digit 3 digit 4 digit 5 digit Auto 2	RW	Auto 2 <sup>4</sup>	-	P.122
10-10	Device root menu ▶ Detailed setup ▶ Display ▶ Display format ▶ Display format total 1	Device setup ▶ Detailed setup ▶ Display set ▶ Disp format ▶ Format total 1	Auto 0 digit 1 digit 2 digit 3 digit 4 digit	Auto 0 digit 1 digit 2 digit 3 digit 4 digit	RW	Auto	-	P.122
10-11	Device root menu ▶ Detailed setup ▶ Display ▶ Display format ▶ Display format total 2	Device setup ▶ Detailed setup ▶ Display set ▶ Disp format ▶ Format total 2	5 digit 6 digit 7 digit	5 digit 6 digit 7 digit	RW			
10-12	Device root menu ▶ Detailed setup ▶ Display ▶ Display format ▶ Display format total 3	Device setup ▶ Detailed setup ▶ Display set ▶ Disp format ▶ Format total 3			RW			

\*1: Determined based on the information about specified items at the time of ordering and the sensor to be combined with.

\*2: The range of single precision float (IEEE 754).

\*3: When Main soft rev (Main board revision/Main soft rev) is R2.01.01 or earlier, the default value is Manual.

\*4: When Main soft rev (Main board revision/Main soft rev) is R2.01.01 or earlier, the default value is "Auto".

No.	Parameter Name		Data Range		RW	Default Value	Unit	Reference
	HART	Display	HART	Display				
10-13	Device root menu ▶ Detailed setup ▶ Display ▶ Display operation configuration ▶ Display contrast	Device setup ▶ Detailed setup ▶ Display set ▶ Optional config ▶ Contrast	-5 -4 -3 -2 -1 0 +1 +2 +3 +4 +5	-5 -4 -3 -2 -1 0 1 2 3 4 5	RW	0	-	P.128
10-14	Device root menu ▶ Detailed setup ▶ Display ▶ Display operation configuration ▶ Display line	Device setup ▶ Detailed setup ▶ Display set ▶ Optional config ▶ Line mode	1 Line(Big) 1 Line 2 Line 3 Line 4 Line	1 line(big) 1 line 2 line 3 line 4 line	RW	3 line	-	P.124
10-15	Device root menu ▶ Detailed setup ▶ Display ▶ Display operation configuration ▶ Display period	Device setup ▶ Detailed setup ▶ Display set ▶ Optional config ▶ Period	0.2 s 0.4 s 1.0 s 2.0 s 4.0 s 8.0 s	0.2 s 0.4 s 1.0 s 2.0 s 4.0 s 8.0 s	RW	0.4 s	-	P.127
10-16	Device root menu ▶ Detailed setup ▶ Display ▶ Display operation configuration ▶ Display NE107	Device setup ▶ Detailed setup ▶ Display set ▶ Optional config ▶ NE107 display	Normal NE107	Normal NE107	RW	Normal	-	P.110
10-17	Device root menu ▶ Detailed setup ▶ Display ▶ Display operation configuration ▶ Display alarm	Device setup ▶ Detailed setup ▶ Display set ▶ Optional config ▶ Alarm display	Normal Detail	Normal Detail	RW	Normal	-	P.110
10-18	Device root menu ▶ Detailed setup ▶ Display ▶ Display operation configuration ▶ Display scroll	Device setup ▶ Detailed setup ▶ Display set ▶ Optional config ▶ Scroll mode	Off Manual Auto(2 s) Auto(4 s) Auto(8 s)	Off Manual Auto(2 s) Auto(4 s) Auto(8 s)	RW	Off <sup>3</sup>	-	P.124
10-19	Device root menu ▶ Detailed setup ▶ Display ▶ Display operation configuration ▶ Display damping	Device setup ▶ Detailed setup ▶ Display set ▶ Optional config ▶ Damp	0.0 to 200.0 Number of decimal places: 1	0.0 to 200.0 Number of decimal places: 1	RW	0.0	s	P.128
10-20	Device root menu ▶ Detailed setup ▶ Display ▶ Display operation configuration ▶ Display format date	Device setup ▶ Detailed setup ▶ Display set ▶ Optional config ▶ Format date	MM/DD/YYYY DD/MM/YYYY YYYY/MM/DD	MM/DD/YYYY DD/MM/YYYY YYYY/MM/DD	RW	MM/DD/YYYY	-	P.128
10-21	Device root menu ▶ Detailed setup ▶ Display ▶ Display operation configuration ▶ Language	Device setup ▶ Language	English French German Italian Spanish Portuguese Russian Chinese Japanese	English French German Italian Spanish Portuguese Russian Chinese Japanese	RW	English	-	P.120
10-22	Device root menu ▶ Detailed setup ▶ Display ▶ Display operation configuration ▶ Display measure mode	Device setup ▶ Detailed setup ▶ Display set ▶ Optional config ▶ Display mode	Normal Trend	Normal Trend	RW	Normal	-	P.126
10-23	Device root menu ▶ Detailed setup ▶ Display ▶ Display operation configuration ▶ Trend offline lrv	Device setup ▶ Detailed setup ▶ Display set ▶ Optional config ▶ Trend offIn LRV	-INF <sup>2</sup> to +INF <sup>2</sup> Number of decimal places: 0 to 5	-999999 to +999999 Number of decimal places: 0 to 5	RW	0.0	-	P.127

\*1: Determined based on the information about specified items at the time of ordering and the sensor to be combined with.

\*2: The range of single precision float (IEEE 754).

\*3: When Main soft rev (Main board revision/Main soft rev) is R2.01.01 or earlier, the default value is Manual.

\*4: When Main soft rev (Main board revision/Main soft rev) is R2.01.01 or earlier, the default value is "Auto".

No.	Parameter Name		Data Range		RW	Default Value	Unit	Reference
	HART	Display	HART	Display				
10-24	Device root menu ▶ Detailed setup ▶ Display ▶ Display operation configuration ▶ Trend offline urv	Device setup ▶ Detailed setup ▶ Display set ▶ Optional config ▶ Trend offIn URV	-INF <sup>2</sup> to +INF <sup>2</sup> Number of decimal places: 0 to 5	-999999 to +999999 Number of decimal places: 0 to 5	RW	10.0	-	P.127
10-25	Device root menu ▶ Detailed setup ▶ Display ▶ Trend select ▶ Trend select 1	Device setup ▶ Detailed setup ▶ Display set ▶ Trend select ▶ Trend 1	Flow rate(%) PV Velocity Volume flow Mass flow Calorie <sup>(G)</sup> Analog out1 Analog out2 <sup>(G)</sup> Totalizer1 Totalizer2 Totalizer3	Flow rate(%) PV Velocity Volume flow Mass flow Calorie <sup>(G)</sup> Analog out 1 Analog out 2 <sup>(G)</sup> Totalizer 1 Totalizer 2 Totalizer 3	RW	PV	-	P.126
10-26	Device root menu ▶ Detailed setup ▶ Display ▶ Trend select ▶ Trend select 2	Device setup ▶ Detailed setup ▶ Display set ▶ Trend select ▶ Trend 2	None Flow rate(%) PV Velocity Volume flow	None Flow rate(%) PV Velocity Volume flow	RW	None	-	P.126
10-27	Device root menu ▶ Detailed setup ▶ Display ▶ Trend select ▶ Trend select 3	Device setup ▶ Detailed setup ▶ Display set ▶ Trend select ▶ Trend 3	Mass flow Calorie <sup>(G)</sup> Analog out1 Analog out2 <sup>(G)</sup> Totalizer1 Totalizer2 Totalizer3	Mass flow Calorie <sup>(G)</sup> Analog out 1 Analog out 2 <sup>(G)</sup> Totalizer 1 Totalizer 2 Totalizer 3	RW	None	-	P.126
10-28	Device root menu ▶ Detailed setup ▶ Display ▶ Trend select ▶ Trend select 4	Device setup ▶ Detailed setup ▶ Display set ▶ Trend select ▶ Trend 4			RW	None	-	P.126
10-29	Device root menu ▶ Detailed setup ▶ Display ▶ Display operation configuration ▶ Display inversion	Device setup ▶ Detailed setup ▶ Display set ▶ Optional config ▶ Inversion	Normal Invert	Normal Invert	RW	Normal	-	P.129
10-30	Maintenance root menu ▶ Display indication ▶ LCD test	Device setup ▶ Diag/Service ▶ Disp indicator ▶ LCD test	Not execute Execute Show Pattern1 Show Pattern2 Show Pattern3 Show Pattern4	Not execute Execute Show pattern 1 Show pattern 2 Show pattern 3 Show pattern 4	RW	Not execute	-	-
10-31	Maintenance root menu ▶ Display indication ▶ Squawk	Device setup ▶ Diag/Service ▶ Disp indicator ▶ Squawk	Off On Squawk Once	Off On Squawk once	RW	Off	-	P.129
10-32	Device root menu ▶ Detailed setup ▶ Display ▶ Display operation configuration ▶ Language package	Device setup ▶ Detailed setup ▶ Display set ▶ Optional config ▶ Language package	Package 1 Package 2	Pack 1 Pack 2	R	- <sup>1</sup>	-	P.120
10-33	Device root menu ▶ Detailed setup ▶ Display ▶ Display operation configuration ▶ Display installation	Device setup ▶ Detailed setup ▶ Device info ▶ Order info ▶ Disp install	No disp With disp	No disp With disp	RW	With disp <sup>1</sup>	-	-
10-34	Device root menu ▶ Detailed setup ▶ Display ▶ Display operation configuration ▶ IRSW operation	-	Disable Enable	-	RW	Enable	-	P.129
10-35	Device root menu ▶ Detailed setup ▶ Display ▶ Display operation configuration ▶ Display time	Device setup ▶ Detailed setup ▶ Display set ▶ Optional config ▶ Time display	Current time Operation days Off	Current time Operation days Off	RW	Operation days	-	P.130

\*1: Determined based on the information about specified items at the time of ordering and the sensor to be combined with.

\*2: The range of single precision float (IEEE 754).

\*3: When Main soft rev (Main board revision/Main soft rev) is R2.01.01 or earlier, the default value is Manual.

\*4: When Main soft rev (Main board revision/Main soft rev) is R2.01.01 or earlier, the default value is "Auto".

# 5.11 Device Information Configuration Parameters

These parameters are related to the device information.

No.	Parameter Name		Data Range		RW	Default Value	Unit	Reference
	HART	Display	HART	Display				
11-1	Device root menu ▶ Detailed setup ▶ Device information ▶ Order information ▶ Tag	Device setup ▶ Detailed setup ▶ ▶ Device info ▶ Order info ▶ Tag No	ASCII 8 characters	ASCII 8 characters	RW	All Space *1	-	P.133
	Device root menu ▶ Detailed setup ▶ Device information ▶ Order information ▶ Long tag	Device setup ▶ Detailed setup ▶ ▶ Device info ▶ ▶ Order info ▶ Long tag	ASCII 32 characters	ASCII 32 characters	RW	All Space *1	-	P.133
11-2	Maintenance root menu ▶ Time stamp ▶ ▶ Operation time	Device setup ▶ Detailed setup ▶ ▶ Device info ▶ ▶ Date/Time ▶ Operation time	00000D 00: 00 to 99999D 23: 59	00000D 00: 00 to 99999D 23: 59	R	00000D 00: 00	-	P.136
11-3	Maintenance root menu ▶ Time stamp ▶ ▶ Current Date	Device setup ▶ Detailed setup ▶ ▶ Device info ▶ ▶ Date/Time ▶ Current date	01/01/1900 to 12/31/2155	01/01/1900 to 12/31/2155	R	1900/01/01	-	P.135
11-4	Maintenance root menu ▶ Time stamp ▶ ▶ Current Time	Device setup ▶ Detailed setup ▶ ▶ Device info ▶ ▶ Date/Time ▶ Current time	00: 00: 00 to 23: 59: 59	00: 00: 00 to 23: 59: 59	R	00: 00: 00	-	P.135
11-5	-	Device setup ▶ Detailed setup ▶ ▶ Device info ▶ ▶ Date/Time ▶ Set date	-	01/01/1900 to 12/31/2155	RW	01/01/1900	-	P.135
	-	Device setup ▶ Detailed setup ▶ ▶ Device info ▶ ▶ Date/Time ▶ Set time	-	00: 00: 00 to 23: 59: 59	RW	00: 00: 00	-	P.135
	Maintenance root menu ▶ Time stamp ▶ ▶ Set Date/Time	-	01/01/1900 00: 00: 00 to 12/31/2155 23: 59: 59	-	RW	01/01/1900 00: 00: 00	-	P.135
11-6	Device root menu ▶ Detailed setup ▶ Device information ▶ Version/Number information ▶ Transmitter type	Device setup ▶ Detailed setup ▶ ▶ Device info ▶ Ver/Num info ▶ Transmitter type	Non 1A Type	None 1A type	R	-	-	P.134
11-7	Device root menu ▶ Detailed setup ▶ Device information ▶ Version/Number information ▶ Option board ID	Device setup ▶ Detailed setup ▶ ▶ Device info ▶ Ver/Num info ▶ Option board ID	Non Multi	None Multi	R	-	-	P.134
11-8	Device root menu ▶ Detailed setup ▶ Device information ▶ Order information ▶ Electrode size	Device setup ▶ Detailed setup ▶ ▶ Device info ▶ ▶ Order info ▶ Electrode size	1 mm 3 mm 8 mm 10 mm 6 mm	1 mm 3 mm 8 mm 10 mm 6 mm	RW	3 mm	-	P.148
11-9	Device root menu ▶ Detailed setup ▶ Device information ▶ Order information ▶ Basic model code	Device setup ▶ Detailed setup ▶ ▶ Device info ▶ ▶ Order info ▶ ▶ MS code ▶ Model code	ASCII 16 characters	ASCII 16 characters	RW	All Space *1	-	P.133

\*1: Determined based on the information about specified items at the time of ordering and the sensor to be combined with.

\*4: Set at the factory before shipment.

No.	Parameter Name		Data Range		RW	Default Value	Unit	Reference
	HART	Display	HART	Display				
11-10	Device root menu ▶ Detailed setup ▶ Device information ▶ Order information ▶ Suffix config 1	Device setup ▶ Detailed setup ▶ Device info ▶ Order info ▶ MS code ▶ Suffix config 1	ASCII 16 characters	ASCII 16 characters	RW	All Space *1	-	P.133
	Device root menu ▶ Detailed setup ▶ Device information ▶ Order information ▶ Suffix config 2	Device setup ▶ Detailed setup ▶ Device info ▶ Order info ▶ MS code ▶ Suffix config 2	ASCII 16 characters	ASCII 16 characters	RW	All Space *1	-	P.133
11-11	Device root menu ▶ Detailed setup ▶ Device information ▶ Order information ▶ Option 1	Device setup ▶ Detailed setup ▶ Device info ▶ Order info ▶ MS code ▶ Option 1	ASCII 16 characters	ASCII 16 characters	RW	All Space *1	-	P.133
	Device root menu ▶ Detailed setup ▶ Device information ▶ Order information ▶ Option 2	Device setup ▶ Detailed setup ▶ Device info ▶ Order info ▶ MS code ▶ Option 2	ASCII 16 characters	ASCII 16 characters	RW	All Space *1	-	P.133
	Device root menu ▶ Detailed setup ▶ Device information ▶ Order information ▶ Option 3	Device setup ▶ Detailed setup ▶ Device info ▶ Order info ▶ MS code ▶ Option 3	ASCII 16 characters	ASCII 16 characters	RW	All Space *1	-	P.133
	Device root menu ▶ Detailed setup ▶ Device information ▶ Order information ▶ Option 4	Device setup ▶ Detailed setup ▶ Device info ▶ Order info ▶ MS code ▶ Option 4	ASCII 16 characters	ASCII 16 characters	RW	All Space *1	-	P.133
11-12	Device root menu ▶ Detailed setup ▶ Device information ▶ Order information ▶ Remote sensor basic model code	Device setup ▶ Detailed setup ▶ Device info ▶ Order info ▶ RS MS code ▶ Model code	ASCII 16 characters	ASCII 16 characters	RW	All Space *1	-	P.133
11-13	Device root menu ▶ Detailed setup ▶ Device information ▶ Order information ▶ Remote sensor suffix config 1	Device setup ▶ Detailed setup ▶ Device info ▶ Order info ▶ RS MS code ▶ Suffix config 1	ASCII 16 characters	ASCII 16 characters	RW	All Space *1	-	P.133
	Device root menu ▶ Detailed setup ▶ Device information ▶ Order information ▶ Remote sensor suffix config 2	Device setup ▶ Detailed setup ▶ Device info ▶ Order info ▶ RS MS code ▶ Suffix config 2	ASCII 16 characters	ASCII 16 characters	RW	All Space *1	-	P.133
11-14	Device root menu ▶ Detailed setup ▶ Device information ▶ Order information ▶ Remote sensor option 1	Device setup ▶ Detailed setup ▶ Device info ▶ Order info ▶ RS MS code ▶ Option 1	ASCII 16 characters	ASCII 16 characters	RW	All Space *1	-	P.133
	Device root menu ▶ Detailed setup ▶ Device information ▶ Order information ▶ Remote sensor option 2	Device setup ▶ Detailed setup ▶ Device info ▶ Order info ▶ RS MS code ▶ Option 2	ASCII 16 characters	ASCII 16 characters	RW	All Space *1	-	P.133
	Device root menu ▶ Detailed setup ▶ Device information ▶ Order information ▶ Remote sensor option 3	Device setup ▶ Detailed setup ▶ Device info ▶ Order info ▶ RS MS code ▶ Option 3	ASCII 16 characters	ASCII 16 characters	RW	All Space *1	-	P.133
	Device root menu ▶ Detailed setup ▶ Device information ▶ Order information ▶ Remote sensor option 4	Device setup ▶ Detailed setup ▶ Device info ▶ Order info ▶ RS MS code ▶ Option 4	ASCII 16 characters	ASCII 16 characters	RW	All Space *1	-	P.133

\*1: Determined based on the information about specified items at the time of ordering and the sensor to be combined with.

\*4: Set at the factory before shipment.



No.	Parameter Name		Data Range		RW	Default Value	Unit	Reference
	HART	Display	HART	Display				
11-15	Device root menu ▶ Detailed setup ▶ Device information ▶ Version/Number information ▶ Transmitter serial No	Device setup ▶ Detailed setup ▶ Device info ▶ Ver/Num info ▶ Trans serial No	ASCII 16 characters	ASCII 16 characters	RW	All Space	-	P.133
11-16	Device root menu ▶ Detailed setup ▶ Device information ▶ Version/Number information ▶ Sensor serial No	Device setup ▶ Detailed setup ▶ Device info ▶ Ver/Num info ▶ Sensor serial No	ASCII 16 characters	ASCII 16 characters	RW	All Space	-	P.133
11-17	Device root menu ▶ Detailed setup ▶ Device information ▶ Memo ▶ Memo 1	Device setup ▶ Detailed setup ▶ Device info ▶ Memo ▶ Memo 1	ASCII 16 characters	ASCII 16 characters	RW	All Space	-	P.135
	Device root menu ▶ Detailed setup ▶ Device information ▶ Memo ▶ Memo 2	Device setup ▶ Detailed setup ▶ Device info ▶ Memo ▶ Memo 2	ASCII 16 characters	ASCII 16 characters	RW	All Space	-	P.135
	Device root menu ▶ Detailed setup ▶ Device information ▶ Memo ▶ Memo 3	Device setup ▶ Detailed setup ▶ Device info ▶ Memo ▶ Memo 3	ASCII 16 characters	ASCII 16 characters	RW	All Space	-	P.135
11-18	Device root menu ▶ Detailed setup ▶ Device information ▶ Version/Number information ▶ Main board revision	Device setup ▶ Detailed setup ▶ Device info ▶ Ver/Num info ▶ Main soft rev	R2.01.01 <sup>*4</sup>	R2.01.01 <sup>*4</sup>	R	-	-	P.134
11-19	Device root menu ▶ Detailed setup ▶ Device information ▶ Version/Number information ▶ Sensor board revision	Device setup ▶ Detailed setup ▶ Device info ▶ Ver/Num info ▶ Snsr soft rev	R1.01.01 <sup>*4</sup>	R1.01.01 <sup>*4</sup>	R	-	-	P.134
11-20	Device root menu ▶ Detailed setup ▶ Device information ▶ Version/Number information ▶ Indicator board revision	Device setup ▶ Detailed setup ▶ Device info ▶ Ver/Num info ▶ Ind soft rev	R2.01.01 <sup>*4</sup>	R2.01.01 <sup>*4</sup>	R	-	-	P.134
11-21	Device root menu ▶ Detailed setup ▶ Device information ▶ Order information ▶ Explosion protection	Device setup ▶ Detailed setup ▶ Device info ▶ Order info ▶ Explosion protection	No/Yes	No/Yes	RW	No	-	P.136
11-22	Device root menu ▶ Detailed setup ▶ Device information ▶ IO Status ▶ IO1	Device setup ▶ Detailed setup ▶ Device info ▶ IO status ▶ I/O 1	AO1 Act AO1 Pas	AO1 Act AO1 Pas	R	*1	-	-
	Device root menu ▶ Detailed setup ▶ Device information ▶ IO Status ▶ IO2	Device setup ▶ Detailed setup ▶ Device info ▶ IO status ▶ I/O 2	PLS/SO1 Pas NM1	PLS/SO1 Pas PLS/SO1 Pas(NAMUR)	R	*1	-	-
	Device root menu ▶ Detailed setup ▶ Device information ▶ IO Status ▶ IO3	Device setup ▶ Detailed setup ▶ Device info ▶ IO status ▶ I/O 3	NAN AO2 Pas PLS/SO2 Pas SO3 Pas SI3 V-Free	None AO2 Pas PLS/SO2 Pas SO3 Pas SI3 V-Free	R	*1	-	-
	Device root menu ▶ Detailed setup ▶ Device information ▶ IO Status ▶ IO4	Device setup ▶ Detailed setup ▶ Device info ▶ IO status ▶ I/O 4	NAN AO2 Act AI Act PLS/SO2 Pas PLS/SO2 Act1 PLS/SO2 Act2/3 NM2	None AO2 Act AI Act PLS/SO2 Pas PLS/SO2 Act1 PLS/SO2 Act2/3 PLS/SO2 Pas(NAMUR)	R	*1	-	-

\*1: Determined based on the information about specified items at the time of ordering and the sensor to be combined with.

\*4: Set at the factory before shipment.

# 5.12 Diagnosis Function Configuration Parameters

These parameters are related to the electrode adhesion detection, flow noise diagnosis, and verification function settings.

No.	Parameter Name		Data Range		R/W	Default Value	Unit	Reference
	HART	Display	HART	Display				
12-1	Diagnostic rootmenu ▶ Diagnosis ▶ Adhesion ▶ Adhesion function	Device setup ▶ Diag/Service ▶ Diagnosis ▶ Adhesion ▶ Function	Disable Enable	Disable Enable	RW	Enable	-	P.139
12-2	Diagnostic rootmenu ▶ Diagnosis ▶ Adhesion ▶ Adhesion level 1	Device setup ▶ Diag/Service ▶ Diagnosis ▶ Adhesion ▶ Threshold level 1	0.00 to +100.00 Number of decimal places: 2	0.00 to +100.00 Number of decimal places: 2	RW	0.10	M ohm	P.139
12-3	Diagnostic rootmenu ▶ Diagnosis ▶ Adhesion ▶ Adhesion level 2	Device setup ▶ Diag/Service ▶ Diagnosis ▶ Adhesion ▶ Threshold level 2	0.00 to +100.00 Number of decimal places: 2	0.00 to +100.00 Number of decimal places: 2	RW	0.50	M ohm	P.139
12-4	Diagnostic rootmenu ▶ Diagnosis ▶ Adhesion ▶ Adhesion level 3	Device setup ▶ Diag/Service ▶ Diagnosis ▶ Adhesion ▶ Threshold level 3	0.00 to +100.00 Number of decimal places: 2	0.00 to +100.00 Number of decimal places: 2	RW	4.00	M ohm	P.139
12-5	Diagnostic rootmenu ▶ Diagnosis ▶ Adhesion ▶ Adhesion level 4	Device setup ▶ Diag/Service ▶ Diagnosis ▶ Adhesion ▶ Threshold level 4	0.00 to +100.00 Number of decimal places: 2	0.00 to +100.00 Number of decimal places: 2	RW	12.00	M ohm	P.139
12-6	Diagnostic rootmenu ▶ Diagnosis ▶ Adhesion ▶ Result ▶ Adhesion value	Device setup ▶ Diag/Service ▶ Diagnosis ▶ Adhesion ▶ Result ▶ Value	0.00000 to +1000.0 Number of decimal places: 0 to 5	0.00000 to +1000.0 Number of decimal places: 0 to 5	R	-	M ohm	P.139
12-7	Diagnostic rootmenu ▶ Diagnosis ▶ Adhesion ▶ Result ▶ Adhesion status	Device setup ▶ Diag/Service ▶ Diagnosis ▶ Adhesion ▶ Result ▶ Status	Level0 Level1 Level2 Level3 Level4	Level 0 Level 1 Level 2 Level 3 Level 4	R	-	-	P.139
12-8	Diagnostic rootmenu ▶ Diagnosis ▶ Adhesion ▶ Adhesion check cycle	Device setup ▶ Diag/Service ▶ Diagnosis ▶ Adhesion ▶ Check cycle	0.5 min 1 min 2 min 10 min	0.5 min 1 min 2 min 10 min	RW	2 min	-	P.139
12-9 (G)	Diagnostic rootmenu ▶ Diagnosis ▶ Flow noise ▶ Flow noise function	Device setup ▶ Diag/Service ▶ Diagnosis ▶ Flow noise ▶ Function	Disable Enable	Disable Enable	RW	Disable	-	P.147
12-10 (G)	Diagnostic rootmenu ▶ Diagnosis ▶ Flow noise ▶ Flow noise level 1	Device setup ▶ Diag/Service ▶ Diagnosis ▶ Flow noise ▶ Threshold level 1	0.0 to +999.9 Number of decimal places: 1	0.0 to +999.9 Number of decimal places: 1	RW	5.0	cm/s	P.147
12-11 (G)	Diagnostic rootmenu ▶ Diagnosis ▶ Flow noise ▶ Flow noise level 2	Device setup ▶ Diag/Service ▶ Diagnosis ▶ Flow noise ▶ Threshold level 2	0.0 to +999.9 Number of decimal places: 1	0.0 to +999.9 Number of decimal places: 1	RW	10.0	cm/s	P.147
12-12 (G)	Diagnostic rootmenu ▶ Diagnosis ▶ Flow noise ▶ Flow noise level 3	Device setup ▶ Diag/Service ▶ Diagnosis ▶ Flow noise ▶ Threshold level 3	0.0 to +999.9 Number of decimal places: 1	0.0 to +999.9 Number of decimal places: 1	RW	30.0	cm/s	P.147
12-13 (G)	Diagnostic rootmenu ▶ Diagnosis ▶ Flow noise ▶ Flow noise level 4	Device setup ▶ Diag/Service ▶ Diagnosis ▶ Flow noise ▶ Threshold level 4	0.0 to +999.9 Number of decimal places: 1	0.0 to +999.9 Number of decimal places: 1	RW	400.0	cm/s	P.147
12-14 (G)	Diagnostic rootmenu ▶ Diagnosis ▶ Flow noise ▶ Result ▶ Flow noise	Device setup ▶ Diag/Service ▶ Diagnosis ▶ Flow noise ▶ Result ▶ Value	0.00000 to +100.00 Number of decimal places: 0 to 5	0.00000 to +100.00 Number of decimal places: 0 to 5	R	-	cm/s	P.147

\*2: The range of single precision float (IEEE 754).

No.	Parameter Name		Data Range		RW	Default Value	Unit	Reference
	HART	Display	HART	Display				
12-15 (G)	Diagnostic rootmenu ▶ Diagnosis ▶ Flow noise ▶ Result ▶ Flow noise status	Device setup ▶ Diag/Service ▶ Diagnosis ▶ Flow noise ▶ Result ▶ Status	Level0 Level1 Level2 Level3 Level4	Level 0 Level 1 Level 2 Level 3 Level 4	R	-	-	P.147
12-16 (G)	Diagnostic rootmenu ▶ Diagnosis ▶ Flow noise ▶ Flow noise damping	Device setup ▶ Diag/Service ▶ Diagnosis ▶ Flow noise ▶ Damp	0.1 to 500.0 Number of decimal places: 1	0.1 to 500.0 Number of decimal places: 1	RW	3.0	s	P.46
12-17 (G)	Diagnostic rootmenu ▶ Diagnosis ▶ Flow noise ▶ Flow noise span	Device setup ▶ Diag/Service ▶ Diagnosis ▶ Flow noise ▶ Span	0.1 to 999.9 Number of decimal places: 1	0.1 to 999.9 Number of decimal places: 1	RW	150.0	cm/s	P.44
12-18 (G)	Diagnostic rootmenu ▶ Diagnosis ▶ Conductivity ▶ Low conductivity function	Device setup ▶ Diag/Service ▶ Diagnosis ▶ Conductivity ▶ Function	Disable Enable	Disable Enable	RW	Disable	-	P.148
12-19 (G)	Diagnostic rootmenu ▶ Diagnosis ▶ Conductivity ▶ Result ▶ Conductivity value	Device setup ▶ Diag/Service ▶ Diagnosis ▶ Conductivity ▶ Result ▶ Value	0.00000 to +INF <sup>2</sup> Number of decimal places: 0 to 5	0.00000 to 999999 Number of decimal places: 0 to 5	R	-	mS/cm	P.148
12-20 (G)	Diagnostic rootmenu ▶ Diagnosis ▶ Conductivity ▶ Conductivity low limit	Device setup ▶ Diag/Service ▶ Diagnosis ▶ Conductivity ▶ Low limit	0.0000 to 99.9999 Number of decimal places: 4	0.0000 to 99.9999 Number of decimal places: 4	RW	0.0010	mS/cm	P.148
12-21	Diagnostic rootmenu ▶ Diagnosis ▶ Diagnostic Exe	Device setup ▶ Diag/Service ▶ Diagnosis ▶ Diagnostic execute	Not execute Elec ins exe Conn chk exe	Not execute Electrode insul exe Connect check exe	RW	Not execute	-	P.141 P.146
12-22	Diagnostic rootmenu ▶ Diagnosis ▶ Coil insulation threshold	Device setup ▶ Diag/Service ▶ Diagnosis ▶ Coil insul threshold	0.0 to 100.0 Number of decimal places: 1	0.0 to 100.0 Number of decimal places: 1	RW	25.0	%	P.149
12-23	Diagnostic rootmenu ▶ Diagnosis ▶ IEX compare	Device setup ▶ Diag/Service ▶ Diagnosis ▶ IEX compare	0.0 to 999.9 Number of decimal places: 1	0.0 to 999.9 Number of decimal places: 1	R	260.0	mA	P.149
12-24 (G)	Diagnostic rootmenu ▶ Diagnosis ▶ V peak hold value	Device setup ▶ Diag/Service ▶ Diagnosis ▶ V peak hold	0.000 to 3.000 Number of decimal places: 3	0.000 to 3.000 Number of decimal places: 3	R	-	V	P.149
12-25	Diagnostic rootmenu ▶ Diagnosis ▶ IEX coil resistance	Device setup ▶ Diag/Service ▶ Diagnosis ▶ IEX resistance	0 to +9999.9 Number of decimal places: 1	0 to +9999.9 Number of decimal places: 1	R	-	ohm	P.149
12-26	Diagnostic rootmenu ▶ Diagnosis ▶ Empty ▶ Electrode voltage A	Device setup ▶ Diag/Service ▶ Diagnosis ▶ Empty check ▶ Electrode voltage A	-3.00 to 3.00 Number of decimal places: 2	-3.00 to 3.00 Number of decimal places: 2	R	-	V	P.140
12-27	Diagnostic rootmenu ▶ Diagnosis ▶ Empty ▶ Electrode voltage B	Device setup ▶ Diag/Service ▶ Diagnosis ▶ Empty check ▶ Electrode voltage B	-3.00 to +3.00 Number of decimal places: 2	-3.00 to +3.00 Number of decimal places: 2	R	-	V	P.140
12-28	Diagnostic rootmenu ▶ Diagnosis ▶ Empty ▶ Result ▶ Empty status	Device setup ▶ Diag/Service ▶ Diagnosis ▶ Empty check ▶ Empty status	Full Empty	Full Empty	R	-	-	P.140
12-29	Diagnostic rootmenu ▶ Diagnosis ▶ Diagnostic output	Device setup ▶ Diag/Service ▶ Diagnosis ▶ Diagnostic output	Zero Measured value Hold	Zero Measured value Hold	RW	Zero	-	P.141 P.142 P.146
12-30	Maintenance root menu ▶ Verification ▶ VF target select	Device setup ▶ Diag/Service ▶ Verification ▶ VF target select	Magnetic Excitation Calculation Device status Conn status	Magnetic circuit Excite circuit Calc circuit Device status Connect status	RW	-	-	P.142
12-31	Maintenance root menu ▶ Verification ▶ VF mode	Device setup ▶ Diag/Service ▶ Verification ▶ Mode	No flow Flow	No flow Flow	RW	No flow	-	P.142
12-32	Maintenance root menu ▶ Verification ▶ Verification Exe	Device setup ▶ Diag/Service ▶ Verification ▶ Execute	Not execute Execute	Not execute Execute	RW	Not execute	-	P.142

\*2: The range of single precision float (IEEE 754).

No.	Parameter Name		Data Range		RW	Default Value	Unit	Reference
	HART	Display	HART	Display				
12-33	Maintenance root menu ▶ Verification ▶ VF No	Device setup ▶ Diag/Service ▶ Verification ▶ VF No	Factory Previous Present	Factory Previous Present	RW	Factory	-	P.142
12-34	Maintenance root menu ▶ Verification ▶ Result ▶ VF check result	Device setup ▶ Diag/Service ▶ Verification ▶ Result ▶ Failed/Passed	Passed Failed Canceled No Data Unknown	Passed Failed Canceled No data Unknown	R	No data	-	P.142
12-35	Maintenance root menu ▶ Verification ▶ Result ▶ VF operation time	Device setup ▶ Diag/Service ▶ Verification ▶ Result ▶ VF operate time	00000D 00: 00 to 99999D 23: 59	00000D 00: 00 to 99999D 23: 59	R	00000D 00: 00	-	P.142
12-36	Maintenance root menu ▶ Verification ▶ Result ▶ Magnetic circuit result	Device setup ▶ Diag/Service ▶ Verification ▶ Result ▶ Magnetic circuit	Passed Failed Canceled No Data Unknown Skip	Passed Failed Canceled No data Unknown Skip	R	No data	-	P.142
12-37	Maintenance root menu ▶ Verification ▶ Result ▶ Excitation circuit result	Device setup ▶ Diag/Service ▶ Verification ▶ Result ▶ Excite circuit	Passed Failed Canceled No Data Unknown Skip	Passed Failed Canceled No data Unknown Skip	R	No data	-	P.142
12-38	Maintenance root menu ▶ Verification ▶ Result ▶ Calculation circuit result	Device setup ▶ Diag/Service ▶ Verification ▶ Result ▶ Calc circuit	Passed Failed Canceled No Data Unknown Skip	Passed Failed Canceled No data Unknown Skip	R	No data	-	P.142
12-39	Maintenance root menu ▶ Verification ▶ Result ▶ VF device status result	Device setup ▶ Diag/Service ▶ Verification ▶ Result ▶ Device status	Passed Failed Canceled No Data Unknown Skip	Passed Failed Canceled No data Unknown Skip	R	No data	-	P.142
12-40	Maintenance root menu ▶ Verification ▶ Result ▶ Connection status result	Device setup ▶ Diag/Service ▶ Verification ▶ Result ▶ Connect status	Passed Failed Canceled No Data Unknown Skip	Passed Failed Canceled No data Unknown Skip	R	No data	-	P.142

\*2: The range of single precision float (IEEE 754).

# 5.13 Test Mode Configuration Parameters

These parameters are related to test mode settings.

No.	Parameter Name		Data Range		RW	Default Value	Unit	Reference
	HART	Display	HART	Display				
13-1	Maintenance root menu ▶ Test ▶ Release time	Device setup ▶ Diag/Service ▶ Test ▶ Release time	10 min 30 min 1 h 3 h 12 h	10 min 30 min 1 h 3 h 12 h	RW	30 min <sup>3</sup>	-	P.152
13-2	Maintenance root menu ▶ Test ▶ Test mode	-	Velocity test on Volume flow test on Mass flow test on Calorific value test on <sup>(G)</sup> AO1 test on Pulse1 test on SO1 test on AO2 test on <sup>(G)</sup> Pulse2 test on SO2 test on AI test on <sup>(G)</sup> SO3 test on SI3 test on	-	RW	All Space	-	P.150
	-	Device setup ▶ Diag/Service ▶ Test ▶ Input test ▶ Test mode	-	Velocity test Volume test Mass test Calorie test <sup>(G)</sup> AI test <sup>(G)</sup> SI3 test	RW	-	-	P.150
	-	Device setup ▶ Diag/Service ▶ Test ▶ Output test ▶ Test mode	-	AO1 test PO1 test SO1 test AO2 test <sup>(G)</sup> PO2 test SO2 test SO3 test	RW	-	-	P.150
13-3	Maintenance root menu ▶ Test ▶ Input test ▶ Velocity	Device setup ▶ Diag/Service ▶ Test ▶ Input test ▶ Velocity	-INF <sup>2</sup> to +INF <sup>2</sup> Number of decimal places: 0 to 5	-999999 to +999999 Number of decimal places: 0 to 5	RW	0.0	No.3-15	P.151
13-4	Maintenance root menu ▶ Test ▶ Input test ▶ Volume flow	Device setup ▶ Diag/Service ▶ Test ▶ Input test ▶ Volume	-INF <sup>2</sup> to +INF <sup>2</sup> Number of decimal places: 0 to 5	-999999 to +999999 Number of decimal places: 0 to 5	RW	0.0	No.3-16/ No.3-19	P.151
13-5	Maintenance root menu ▶ Test ▶ Input test ▶ Mass flow	Device setup ▶ Diag/Service ▶ Test ▶ Input test ▶ Mass flow	-INF <sup>2</sup> to +INF <sup>2</sup> Number of decimal places: 0 to 5	-999999 to +999999 Number of decimal places: 0 to 5	RW	0.0	No.3-17/ No.3-19	P.151
13-6	Maintenance root menu ▶ Test ▶ Input test ▶ Calorific value	Device setup ▶ Diag/Service ▶ Test ▶ Input test ▶ Calorie	-INF <sup>2</sup> to +INF <sup>2</sup> Number of decimal places: 0 to 5	-999999 to +999999 Number of decimal places: 0 to 5	RW	0.0	No.3-18/ No.3-19	P.151
13-7	Maintenance root menu ▶ Test ▶ Input test ▶ SI3	Device setup ▶ Diag/Service ▶ Test ▶ Input test ▶ SI3	Open Short	Open Short	RW	Open	-	P.151
13-8	Maintenance root menu ▶ Test ▶ Output test ▶ AO1	Device setup ▶ Diag/Service ▶ Test ▶ Output test ▶ AO1	2.400 to 21.600 Number of decimal places: 3	2.400 to 21.600 Number of decimal places: 3	RW	4.000	mA	P.151
13-9	Maintenance root menu ▶ Test ▶ Output test ▶ Pulse1	Device setup ▶ Diag/Service ▶ Test ▶ Output test ▶ PO1	0 to 12500 Number of decimal places: 0	0 to 12500 Number of decimal places: 0	RW	0.0	pps (pulse/s)	P.151
13-10	Maintenance root menu ▶ Test ▶ Output test ▶ SO1	Device setup ▶ Diag/Service ▶ Test ▶ Output test ▶ SO1	Open Close	Open Close	RW	Open	-	P.151
13-11 (G)	Maintenance root menu ▶ Test ▶ Output test ▶ AO2	Device setup ▶ Diag/Service ▶ Test ▶ Output test ▶ AO2	2.400 to 21.600 Number of decimal places: 3	2.400 to 21.600 Number of decimal places: 3	RW	4.000	mA	P.151
13-12	Maintenance root menu ▶ Test ▶ Output test ▶ Pulse2	Device setup ▶ Diag/Service ▶ Test ▶ Output test ▶ PO2	0 to 12500 Number of decimal places: 0	0 to 12500 Number of decimal places: 0	RW	0	pps (pulse/s)	P.151
13-13	Maintenance root menu ▶ Test ▶ Output test ▶ SO2	Device setup ▶ Diag/Service ▶ Test ▶ Output test ▶ SO2	Open Close	Open Close	RW	Open	-	P.151

\*2: The range of single precision float (IEEE 754).

\*3: When Main soft rev (Main board revision/Main soft rev) is R2.01.01 or earlier, the default value is "10 min".

No.	Parameter Name		Data Range		RW	Default Value	Unit	Reference
	HART	Display	HART	Display				
13-14	Maintenance root menu ▶ Test ▶ Output test ▶ SO3	Device setup ▶ Diag/Service ▶ Test ▶ Output test ▶ SO3	Open Close	Open Close	RW	Open	-	P.151
13-15 (G)	Maintenance root menu ▶ Test ▶ Input test ▶ AI	Device setup ▶ Diag/Service ▶ Test ▶ Input test ▶ AI	0.000 to 21.600 Number of decimal places: 3	0.000 to 21.600 Number of decimal places: 3	RW	0.000	mA	P.151
13-16	Maintenance root menu ▶ Test ▶ Test 2 mode	Device setup ▶ Diag/Service ▶ Test ▶ Test 2 mode	Normal Test	Normal Test	RW	Normal	-	P.152
13-17	Maintenance root menu ▶ Test ▶ Test 2 output value	Device setup ▶ Diag/Service ▶ Test ▶ Test 2 value	-10.0 to 110.0	-10.0 to 110.0	RW	0.0	%	P.152

\*2: The range of single precision float (IEEE 754).

\*3: When Main soft rev (Main board revision/Main soft rev) is R2.01.01 or earlier, the default value is "10 min".

# 5.14 Backup/Restore/Data Logging Configuration Parameters

These parameters are related to the backup function, restore function and data logging function of parameters.

No.	Parameter Name		Data Range		R/W	Default Value	Unit	Reference
	HART	Display	HART	Display				
14-1	Maintenance root menu ► Param bkup/restore ► Factory backup name	Device setup ► Diag/Service ► Param bkup/restore ► F backup name	ASCII 16 characters	ASCII 16 characters	R	Factory Delivery	-	P.153
14-2	Maintenance root menu ► Param bkup/restore ► Factory backup date	Device setup ► Diag/Service ► Param bkup/restore ► F backup date	ASCII 16 characters	ASCII 16 characters	R	01/01/2019 *4	-	P.153
14-3	Maintenance root menu ► Param bkup/restore ► SD backup name	Device setup ► Diag/Service ► Param bkup/restore ► SD backup name	ASCII 8 characters	ASCII 8 characters	RW	SD_FILE	-	P.153
14-4	Maintenance root menu ► Param bkup/restore ► Backup name 1	Device setup ► Diag/Service ► Param bkup/restore ► Backup name 1	ASCII 16 characters	ASCII 16 characters	RW	Backup 1	-	P.153
14-5	Maintenance root menu ► Param bkup/restore ► Backup date 1	Device setup ► Diag/Service ► Param bkup/restore ► Backup date 1	ASCII 16 characters	ASCII 16 characters	RW	01/01/2019	-	P.153
14-6	Maintenance root menu ► Param bkup/restore ► Backup name 2	Device setup ► Diag/Service ► Param bkup/restore ► Backup name 2	ASCII 16 characters	ASCII 16 characters	RW	Backup 2	-	P.153
14-7	Maintenance root menu ► Param bkup/restore ► Backup date 2	Device setup ► Diag/Service ► Param bkup/restore ► Backup date 2	ASCII 16 characters	ASCII 16 characters	RW	01/01/2019	-	P.153
14-8	Maintenance root menu ► Param bkup/restore ► Backup name 3	Device setup ► Diag/Service ► Param bkup/restore ► Backup name 3	ASCII 16 characters	ASCII 16 characters	RW	Backup 3	-	P.153
14-9	Maintenance root menu ► Param bkup/restore ► Backup date 3	Device setup ► Diag/Service ► Param bkup/restore ► Backup date 3	ASCII 16 characters	ASCII 16 characters	RW	01/01/2019	-	P.153
14-10	Maintenance root menu ► Param bkup/restore ► Backup Exe	Device setup ► Diag/Service ► Param bkup/restore ► Backup execute	Not execute Store Main to 1 Store Main to 2 Store Main to 3 Store Main to SD Store EEP1 to SD Store EEP2 to SD Store EEP3 to SD	Not execute Store main to 1 Store main to 2 Store main to 3 Store main to SD Store EEP1 to SD Store EEP2 to SD Store EEP3 to SD	RW	Not execute	-	P.153
14-11		Device setup ► Diag/Service ► Param bkup/restore ► Backup result	Unexecuted Success Failure Running	Unexecuted Success Failure Running	R	Unexecuted	-	P.153
14-12	Maintenance root menu ► Param bkup/restore ► Restore Exe	Device setup ► Diag/Service ► Param bkup/restore ► Restore execute	Not execute Duplicate Data 1 Duplicate Data 2 Duplicate Data 3 Duplicate SD Restore Data 1 Restore Data 2 Restore Data 3 Restore SD Compulsion Data 1 Compulsion Data 2 Compulsion Data 3 Compulsion SD Restore Factory	Not execute Duplicate data 1 Duplicate data 2 Duplicate data 3 Duplicate SD Restore data 1 Restore data 2 Restore data 3 Restore SD Compulsion data 1 Compulsion data 2 Compulsion data 3 Compulsion SD Restore factory	RW	Not execute	-	P.156
14-13		Device setup ► Diag/Service ► Param bkup/restore ► Restore result	Unexecuted Success Failure Running	Unexecuted Success Failure Running	R	Unexecuted	-	P.156

\*4: Set at the factory before shipment.

No.	Parameter Name		Data Range		RW	Default Value	Unit	Reference
	HART	Display	HART	Display				
14-14	Maintenance root menu ► Data logging ► File name	Device setup ► Diag/Service ► Data log ► File name	ASCII 8 characters	ASCII 8 characters	RW	LOG_FILE	-	P.164
14-15	Maintenance root menu ► Data logging ► Interval time	Device setup ► Diag/Service ► Data log ► Interval time	1 s 10 s 30 s 1 min 5 min 30 min 1 h	1 s 10 s 30 s 1 min 5 min 30 min 1 h	RW	1 min	-	P.164
14-16	Maintenance root menu ► Data logging ► Start date	Device setup ► Diag/Service ► Data log ► Start date	01/01/1900 to 31/12/2155	01/01/1900 to 31/12/2155	R	01/01/2019	-	P.164
14-17	Maintenance root menu ► Data logging ► Start time	Device setup ► Diag/Service ► Data log ► Start time	00: 00: 00 to 23: 59: 59	00: 00: 00 to 23: 59: 59	R	00:00:00	-	P.164
14-18	Maintenance root menu ► Data logging ► End time	Device setup ► Diag/Service ► Data log ► End time	10 min 30 min 1 h 3 h 12 h 24 h 72 h 240 h 720 h 1440 h	10 min 30 min 1 h 3 h 12 h 24 h 72 h 240 h 720 h 1440 h	RW	12 h	-	P.164
14-19	Maintenance root menu ► Data logging ► Log1 select	Device setup ► Diag/Service ► Data log ► Log 1	Velocity Volume flow Mass flow Calorie <sup>(G)</sup>	Velocity Volume flow Mass flow Calorie <sup>(G)</sup>	RW	PV	-	P.164
14-20	Maintenance root menu ► Data logging ► Log2 select	Device setup ► Diag/Service ► Data log ► Log 2	PV Flow noise <sup>(G)</sup> Adhesion Electrode A Electrode B V peak <sup>(G)</sup>	PV Flow noise <sup>(G)</sup> Adhesion Electrode A Electrode B V peak <sup>(G)</sup>	RW	Velocity	-	P.164
14-21	Maintenance root menu ► Data logging ► Log3 select	Device setup ► Diag/Service ► Data log ► Log 3			RW	Volume flow	-	P.164
14-22	Maintenance root menu ► Data logging ► Log4 select	Device setup ► Diag/Service ► Data log ► Log 4			RW	Mass flow	-	P.164
14-23	Maintenance root menu ► Data logging ► Logging Exe	Device setup ► Diag/Service ► Data log ► Execute	Not execute Execute	Not execute Execute	RW	Not execute	-	P.164

\*4: Set at the factory before shipment.



## 5.15 Parameter Protection Parameters

These parameters are related to the write protect function.

No.	Parameter Name		Data Range		RW	Default Value	Unit	Reference
	HART	Display	HART	Display				
15-1	-	Device setup ▶ Detailed setup ▶ Protection ▶ Key code	0000 to 9999 Number of decimal places: 0	0000 to 9999 Number of decimal places: 0	RW	0000	-	P.168
15-2	Device root menu ▶ Detailed setup ▶ Protection ▶ Write protect	Device setup ▶ Detailed setup ▶ Protection ▶ Write protect sts	No Yes	No Yes	R	No	-	P.167
15-3	Device root menu ▶ Detailed setup ▶ Protection ▶ Enable write 10 min	Device setup ▶ Detailed setup ▶ Protection ▶ Enable write	ASCII 8 characters	ASCII 8 characters	RW	All Space	-	P.167
15-4	Device root menu ▶ Detailed setup ▶ Protection ▶ New password	Device setup ▶ Detailed setup ▶ Protection ▶ New password	ASCII 8 characters	ASCII 8 characters	RW	All Space	-	P.167
15-5	Device root menu ▶ Detailed setup ▶ Protection ▶ Software seal	Device setup ▶ Detailed setup ▶ Protection ▶ Soft seal status	Keep Break	Keep Break	R	Keep	-	P.167

# 6. Parameter Menu Tree

## NOTE

The available menus and parameters vary depending on communication and I/O code and the optional codes specified at the time of ordering.

## 6.1 Display Menu Tree

The outline of the display menu structure is shown below.

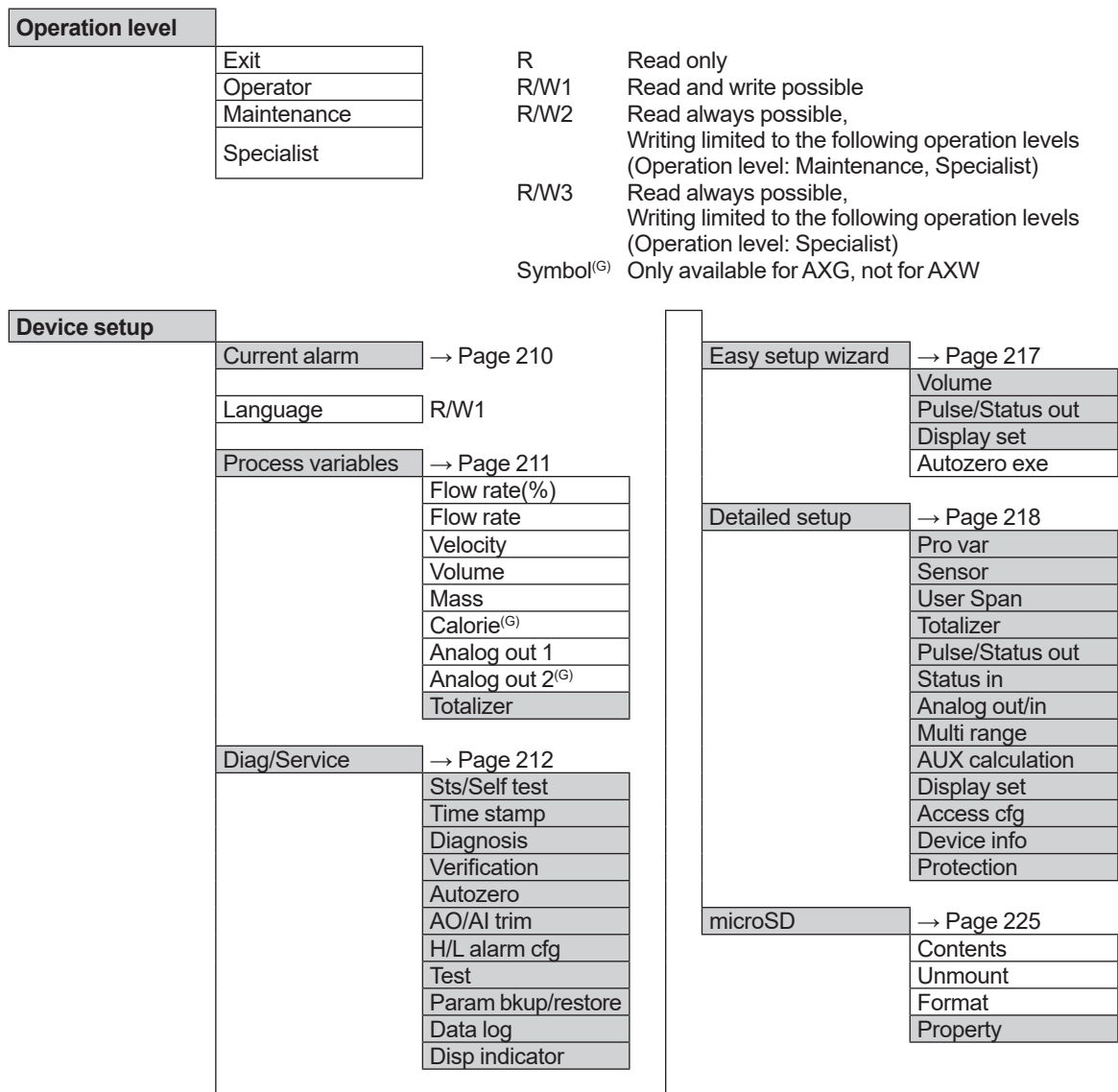

**Current alarm**

Current alarm	
Setting upload	
Status 0	R
Status 1	R
Status 2	R
Status 3	R
Status 4	R
Status 5	R
Status 14	R
Status 15	R
Status 16	R
Status 17	R
Status 18	R
Status 19	R
Status 20	R
Setting download	

Status 0
010:Main CPU FAIL
011:Rev calc FAIL
012:Main EEP FAIL
013:Main EEP dflt

Status 1
014:Snsr bd FAIL
015:Snsr comm ERR
016:AD 1 FAIL[Sig]
017:AD 2 FAIL[Excit]
018:Coil open
019:Coil short
020:Exciter FAIL

Status 2
021:PWM 1 stop
022:PWM 2 stop
023:Opt bd mismatch
024:Opt bd EEP FAIL
025:Opt bd A/D FAIL
026:Opt bd SPI FAIL

Status 3
027:Restore FAIL
028:Ind bd FAIL
029:Ind bd EEP FAIL
030:LCD drv FAIL
031:Ind bd mismatch
032:Ind comm ERR
033:microSD FAIL

Status 4
050:Signal overflow
051:Empty detect
052:H/L HH/LL alm
053:Adh over lv 4

Status 5
060:Span cfg ERR
061:PV F cfg ERR
062:AO 1 4-20 lmt
063:AO 2 4-20 lmt
064:AO 1 mlt rng
065:H/L cfg ERR
066:Density cfg ERR

Status 14
067:Pls 1 cfg ERR
068:Pls 2 cfg ERR
069:Nomi size cfg
070:Adh cfg ERR
071:FLN cfg ERR
072:Log not start

Status 15
080:AO 1 saturate
081:AO 2 saturate
082:Pls 1 saturate
083:Pls 2 saturate
084:AI saturate
085:Cable miscon
086:Coil insulation
131:Trans mismatch

Status 16
087:Adhesion lv 3
088:LC warn
089:Insu detect
090:FLN over lv 3
091:FLN over lv 4
092:AZ warn
093:Verif warn
094:Fact noise warn

Status 17
095:Simulate active
096:AO 1 fix
097:AO 2 fix
098:Pls 1 fix
099:Pls 2 fix
100:AI fix

Status 18
101:Param restore run
102:Disp over
103:SD size warn
104:Bkup incmplt
105:SD mismatch
106:SD removal ERR

Status 19
120:Watchdog
121:Power off
122:Inst power FAIL
123:Param bkup run
124>Data log run

Status 20
130:DevID not enter

**NOTE**

Only the status items that occur in HART communication type are described above. Other than the above status items are also displayed on the display unit.

## ■ Process variables

Process variables		
	Flow rate(%)	R
	Flow rate	R
	Velocity	R
	Volume	R
	Mass	R
	Calorie <sup>(G)</sup>	R
	Analog out 1	R
	Analog out 2 <sup>(G)</sup>	R
	Totalizer	
	Totalizer 1	R
	Totalizer 2	R
	Totalizer 3	R
	Totalizer 1 count	R
	Totalizer 2 count	R
	Totalizer 3 count	R

■ Diagnosis/Service

<b>Diag/Service</b>		
Sts/Self test	→ Page 213	
Time stamp		
	Date	R
	Time	R
	Op time	R
Diagnosis	→ Page 214	
Verification	→ Page 215	
Autozero		
	Execute	R/W2
	Result	
	Zero value	R/W3
AO/AI trim	→ Page 215	
H/L alarm cfg		
	High alarm	R/W3
	Low alarm	R/W3
	HH alarm	R/W3
	LL alarm	R/W3
	H/L alarm hyst	R/W3
	4-20 burnout	R
Test	→ Page 216	
Param bkup/restore		
	F backup name	R
	F backup date	R
	SD backup name	R/W3
	Backup execute	R/W3
	Backup result	R
	Restore execute	R/W3
	Restore result	R
	Backup name 1	R/W3
	Backup date 1	R/W3
	Backup name 2	R/W3
	Backup date 2	R/W3
	Backup name 3	R/W3
	Backup date 3	R/W3
Data log		
	File name	R/W3
	Interval time	R/W3
	Start date	R
	Start time	R
	End time	R/W3
	Execute	R/W3
	Log 1	R/W3
	Log 2	R/W3
	Log 3	R/W3
	Log 4	R/W3
Disp indicator		
	LCD test	R/W1
	Squawk	R/W1

● Status/Self test

<b>Sts/Self test</b>		
<b>Current alarm</b>		
	Status 0	R
	Status 1	R
	Status 2	R
	Status 3	R
	Status 4	R
	Status 5	R
	Status 14	R
	Status 15	R
	Status 16	R
	Status 17	R
	Status 18	R
	Status 19	R
	Status 20	R
<b>Alarm</b>		
<b>Alarm record mask</b>		
	Mask 1-1	R/W3
	Mask 1-2	R/W3
	Mask 2-1	R/W3
	Mask 2-2	R/W3
	Mask 3-1	R/W3
<b>Alarm record</b>		
	Record alarm 1	R
	Record time 1	R
	Record alarm 2	R
	Record time 2	R
	Record alarm 3	R
	Record time 3	R
	Record alarm 4	R
	Record time 4	R
<b>Alarm out mask</b>		
	Mask 1-1	R/W3
	Mask 1-2	R/W3
	Mask 2-1	R/W3
	Mask 2-2	R/W3
	Mask 3-1	R/W3
	Mask 3-2	R/W3
	Mask 4-1	R/W3

● **Diagnosis**

<b>Diagnosis</b>	
<b>Adhesion</b>	
Function	R/W3
Threshold level 1	R/W3
Threshold level 2	R/W3
Threshold level 3	R/W3
Threshold level 4	R/W3
<b>Result</b>	
	Value R
	Status R
Check cycle	R/W3
<b>Flow noise<sup>(G)</sup></b>	
Function	R/W3
Threshold level 1	R/W3
Threshold level 2	R/W3
Threshold level 3	R/W3
Threshold level 4	R/W3
<b>Result</b>	
	Value R
	Status R
Damp	R/W3
Span	R/W3
<b>Conductivity<sup>(G)</sup></b>	
Function	R/W3
Low limit	R/W3
<b>Result</b>	
	Value R
Diagnostic execute	R/W3
Coil insul threshold	R/W3
IEX compare	R
Diagnostic output	R/W3
V peak hold <sup>(G)</sup>	R
IEX resistance	R
<b>Empty check</b>	
	Electrode voltage A R
	Electrode voltage B R
	Empty status R

● Verification

<b>Verification</b>	
Mode	R/W3
Execute	R/W3
VF No	R/W3
VF target select	R/W3
<b>Result</b>	
Failed/Passed	R
VF operate time	R
Magnetic circuit	R
Excite circuit	R
Calc circuit	R
Device status	R
Connect status	R

● Analog output/input adjustment

<b>AO/AI trim</b>	
<b>AO trim</b>	
AO1 trim clear	R/W3
AO1 trim 4mA	R/W3
AO1 trim 20mA	R/W3
AO2 trim clear <sup>(G)</sup>	R/W3
AO2 trim 4mA <sup>(G)</sup>	R/W3
AO2 trim 20mA <sup>(G)</sup>	R/W3
<b>AI trim<sup>(G)</sup></b>	
Trim clear	R/W3
Trim 4mA	R/W3
Trim 20mA	R/W3



● Test

<b>Test</b>		
	Release time	R/W3
	<b>Input test</b>	
		Test mode R/W3
		Velocity R/W3
		Volume R/W3
		Mass R/W3
		Calorie <sup>(G)</sup> R/W3
		AI <sup>(G)</sup> R/W3
		SI3 R/W3
	<b>Output test</b>	
		Test mode R/W3
		AO1 R/W3
		PO1 R/W3
		SO1 R/W3
		AO2 <sup>(G)</sup> R/W3
		PO2 R/W3
		SO2 R/W3
		SO3 R/W3
	Test 2 mode	R/W3
	Test 2 value	R/W3

## ■ Easy setup wizard

Easy setup wizard		
Volume		
	Setting upload	
	Damp AO/F	R/W2
	Damp pls/ttl	R/W2
	Unit	R/W2
	Time unit	R/W2
	Span	R/W2
	Setting download	
Pulse/Status out		
	Setting upload	
	P1 unit	R/W2
	P1 val	R/W2
	F1 at 0%	R/W2
	F1 at 100%	R/W2
	Setting download	
Display set		
	Setting upload	
	Line 1	R/W1
	Line 2	R/W1
	Line 3	R/W1
	Setting download	
Autozero exe	R/W2	

■ Detailed setup

<b>Detailed setup</b>		
Pro var	→ Page 219	
<b>Sensor</b>		
	Low MF	R/W3
	High MF	R/W3
	Flow sensor sel	R/W3
	Nominal size unit	R/W3
	Nominal size	R/W3
User Span	→ Page 219	
Totalizer	→ Page 220	
Pulse/Status out	→ Page 221	
Status in	→ Page 222	
Analog out/in	→ Page 222	
<b>Multi range</b>		
	Forward span 2	R/W3
	Reverse span 1	R/W3
	Reverse span 2	R/W3
	Auto range hyst	R/W3
	Bi direction hyst	R/W3
<b>AUX calculation</b>		
	Flow direct	R/W3
	Rate limit	R/W3
	Dead time	R/W3
	Noise filter	R/W3
	Pulsing flow	R/W3
	Power sync	R/W3
	Set power freq	R/W3
	lex power frequency	R
	Meas power freq	R
	Set SIL	R/W3
Display set	→ Page 223	
<b>Access cfg</b>		
	User role	R
	Chg mainte	R/W2
	Chg special	R/W3
Device info	→ Page 224	
<b>Protection</b>		
	Key code	R/W3
	Write protect sts	R
	Enable write	R/W3
	New password	R/W3
	Soft seal status	R

● Process variables

<b>Pro var</b>		
PV flow select		R/W3
<b>Velocity</b>		
	Damp AO/F	R/W3
	Damp pls/ttl	R/W3
	Unit	R/W3
	Span	R/W3
<b>Volume</b>		
	Damp AO/F	R/W2
	Damp pls/ttl	R/W2
	Unit	R/W2
	Time unit	R/W2
	Span	R/W2
<b>Mass</b>		
	Damp AO/F	R/W3
	Damp pls/ttl	R/W3
	Unit	R/W3
	Time unit	R/W2
	Span	R/W3
<b>Calorie<sup>(G)</sup></b>		
	Damp AO/F	R/W3
	Damp pls/ttl	R/W3
	Unit	R/W3
	Time unit	R/W2
	Span	R/W3
	Specific heat	R/W3
<b>Density</b>		
	Value select <sup>(G)</sup>	R/W3
	Unit	R/W3
	Fixed density	R/W3
	Std density <sup>(G)</sup>	R/W3
	Correct density <sup>(G)</sup>	R
<b>Temperature<sup>(G)</sup></b>		
	Std temperature	R/W3
	Meas temperature	R
	Fixed temperature	R/W3
	Coef A1	R/W3
	Coef A2	R/W3
Velocity check		R

● User span

<b>User Span</b>		
<b>User span AO1</b>		
	Select	R/W3
	Span	R/W3
	Unit	R/W3
<b>User span AO2<sup>(G)</sup></b>		
	Select	R/W3
	Span	R/W3
	Unit	R/W3

● Totalizer

<b>Totalizer</b>	
<b>Totalizer 1</b>	
Unit	R
Conv factor	R/W3
Low cut	R/W3
Failure opts	R/W3
Options	R/W3
Start/Stop	R/W3
Reset/Preset	R/W3
Preset value	R/W3
Set point	R/W3
Count unit	R/W3
<b>Totalizer 2</b>	
Unit	R/W3
Conv factor	R/W3
Low cut	R/W3
Failure opts	R/W3
Options	R/W3
Start/Stop	R/W3
Reset/Preset	R/W3
Preset value	R/W3
Set point	R/W3
Count unit	R/W3
<b>Totalizer 3</b>	
Unit	R/W3
Conv factor	R/W3
Low cut	R/W3
Failure opts	R/W3
Options	R/W3
Start/Stop	R/W3
Reset/Preset	R/W3
Preset value	R/W3
Set point	R/W3
Count unit	R/W3
Reset mode	R/W3

● Pulse/Status output

Pulse/Status out		
PO1/SO1		
Output mode		R/W3
Active mode		R/W3
Fix width		R/W3
Rate unit		R/W2
Rate value		R/W2
Low cut		R/W3
Alarm out		R/W3
Frequency at 0%		R/W2
Frequency at 100%		R/W2
SO1 function		R/W3
Options		R/W3
PO2/SO2		
Active pulse		R/W3
Output mode		R/W3
Pulse select		R/W3
Active mode		R/W3
Fix width		R/W3
Rate unit		R/W3
Rate value		R/W3
Low cut		R/W3
Alarm out		R/W3
Frequency at 0%		R/W3
Frequency at 100%		R/W3
SO2 function		R/W3
Options		R/W3
SO3		
Active mode		R/W3
Function		R/W3

● Status input

Status in			
	SI3		
		Active mode	R/W3
		Function	R/W3
		State	R

● Analog output/input

Analog out/in			
	AO1		
		Low cut	R/W3
		High limit	R/W3
		Low limit	R/W3
		Alarm out	R/W3
		Range mode	R/W3
	AO2 <sup>(G)</sup>		
		AO2 select	R/W3
		Low cut	R/W3
		High limit	R/W3
		Low limit	R/W3
		Alarm out	R/W3
	AI <sup>(G)</sup>		
		Function	R/W3
		High limit	R/W3
		Low limit	R/W3
		Value	R
		Unit	R/W3
		URV	R/W3
		LRV	R/W3

● Display set

Display set		
Line select		
	Line 1	R/W1
	Line 2	R/W1
	Line 3	R/W1
	Line 4	R/W1
	Line 5	R/W1
	Line 6	R/W1
	Line 7	R/W1
	Line 8	R/W1
Trend select		
	Trend 1	R/W1
	Trend 2	R/W1
	Trend 3	R/W1
	Trend 4	R/W1
Disp format		
	Format PV	R/W1
	Format total 1	R/W1
	Format total 2	R/W1
	Format total 3	R/W1
Optional config		
	Contrast	R/W1
	Line mode	R/W1
	Period	R/W1
	NE107 display	R/W1
	Alarm display	R/W1
	Scroll mode	R/W1
	Damp	R/W1
	Format date	R/W1
	Inversion	R/W1
	Language package	R
	Display mode	R/W1
	Trend offIn LRV	R/W1
	Trend offIn URV	R/W1
	Time display	R/W1



● Device information

Device info

Date/Time

Current date	R
Current time	R
Operation time	R
Set date	R/W3
Set time	R/W3

Order info

Tag No	R/W3
Long tag	R/W3
Electrode size	R/W3
Explosion protection	R/W3
MS code	
Model code	R/W3
Suffix config 1	R/W3
Suffix config 2	R/W3
Option 1	R/W3
Option 2	R/W3
Option 3	R/W3
Option 4	R/W3
RS MS code	
Model code	R/W3
Suffix config 1	R/W3
Suffix config 2	R/W3
Option 1	R/W3
Option 2	R/W3
Option 3	R/W3
Option 4	R/W3
Disp install	R/W3

Ver/Num info

Transmitter type	R
Option board ID	R
Trans serial No	R/W3
Sensor serial No	R/W3
Main soft rev	R
Snsr soft rev	R
Ind soft rev	R
Hard rev	R
Dev id	R

IO status

I/O 1	R
I/O 2	R
I/O 3	R
I/O 4	R

Memo

Memo 1	R/W3
Memo 2	R/W3
Memo 3	R/W3

HART info

Poll addr	R/W3
Loop curr mode	R/W3
Num req preams	R
Num resp preams	R/W3

■ microSD

microSD	
Contents	R
Unmount	R/W1
Format	R/W1
Property	
	Total space R
	Available space R
	File system R

# 6.2 HART Communication Menu Tree

The outline of the HART communication menu structure is shown below.

R Read only  
R/W Read and write possible  
Symbol<sup>(G)</sup> Only available for AXG, not for AXW

<b>Online</b>	Process variables root menu	→Page 227
		Dynamic variables
		Device variables
		Device variables status
		Totalizer count
		View outputs
		View inputs
	Diagnostic root menu	→Page 228
		Status/Self test
		Diagnosis
	Maintenance root menu	→Page 231
		Time stamp
		Test
		Autozero
		AO/AI trim
		High/Low alarm configuration
	Verification	
	Param bkup/restore	
	Data logging	
	Display indication	
Device root menu	→Page 233	
	Easy setup wizard	
	Basic setup	
	Detailed setup	

■ Process variables root menu

<b>Process variables root menu</b>	
<b>Dynamic variables</b>	
[PV]	R
[PV] data quality	R
[PV] limit status	R
PV % range	R
Range information	R
[SV]	R
[SV] data quality	R
[SV] limit status	R
[TV]	R
[TV] data quality	R
[TV] limit status	R
[QV]	R
[QV] data quality	R
[QV] limit status	R
PV is	R
SV is	R
TV is	R
QV is	R
Change PV map	
Change SV map	
Change TV map	
Change QV map	
<b>Device variables</b>	
Disp flowrate	R
Disp flowrate%	R
Velocity	R
Volume flow	R
Mass flow	R
Totalizer1	R
Totalizer2	R
Totalizer3	R
Flow noise <sup>(G)</sup>	R
Calorific value <sup>(G)</sup>	R
<b>Device variables status</b>	
Velocity data quality	R
Velocity limit status	R
Volume flow data quality	R
Volume flow limit status	R
Mass flow data quality	R
Mass flow limit status	R
Totalizer1 data quality	R
Totalizer1 limit status	R
Totalizer2 data quality	R
Totalizer2 limit status	R
Totalizer3 data quality	R
Totalizer3 limit status	R
Flow noise data quality <sup>(G)</sup>	R
Flow noise limit status <sup>(G)</sup>	R
Calorific value data quality <sup>(G)</sup>	R
Calorific value limit status <sup>(G)</sup>	R
<b>Totalizer count</b>	
Totalizer1 count	R
Totalizer2 count	R
Totalizer3 count	R
<b>View outputs</b>	
AO1 current	R
Range information	R
AO2 current <sup>(G)</sup>	R
<b>View inputs<sup>(G)</sup></b>	
AI current	R

**Diagnostic root menu**

<b>Diagnostic root menu</b>		
Status/Self test	→Page 229	
	Alarm/Event device status	
	Alarm	
	Condensed status map	
	Device reset	
	Burn out	R
	Reset cfg chng flag	
	Self test	
<b>Diagnosis</b>		
	Diagnostic output	R/W
	Diagnostic Exe	
	<b>Adhesion</b>	
	Adhesion function	R/W
	Adhesion level 1	R/W
	Adhesion level 2	R/W
	Adhesion level 3	R/W
	Adhesion level 4	R/W
	Result	
	Adhesion value	R
	Adhesion status	R
	Adhesion check cycle	R/W
	<b>Flow noise<sup>(G)</sup></b>	
	Flow noise function	R/W
	Flow noise level 1	R/W
	Flow noise level 2	R/W
	Flow noise level 3	R/W
	Flow noise level 4	R/W
	Result	
	Flow noise value	R
	Flow noise status	R
	Flow noise damping	R/W
	Flow noise span	R/W
	<b>Conductivity<sup>(G)</sup></b>	
	Low conductivity function	R/W
	Conductivity low limit	R/W
	Result	
	Conductivity value	R
	<b>Empty</b>	
	Electrode voltage A	R
	Electrode voltage B	R
	Result	
	Empty status	R
	Coil insulation threshold	R/W
	IEX compare	R
	V peak hold value <sup>(G)</sup>	R
	IEX coil resistance	R

● Status/Self test

<b>Status/Self test</b>			
<b>Alarm/Event device status</b>		<b>Condensed status map</b>	
Device status	R	Device status	R/W
Status group 0	R	Status group 0	R/W
Status group 1	R	Status group 1	R/W
Status group 2	R	Status group 2	R/W
Status group 3	R	Status group 3	R/W
Status group 4	R	Status group 4	R/W
Status group 5	R	Status group 5	R/W
Ext dev status	R	Ext dev status	R/W
Device Diagnostic Status 0	R	Device Diagnostic Status 0	R/W
Device Diagnostic Status 1	R	Device Diagnostic Status 1	R/W
AO saturated	R	AO saturated	R/W
I/O and Subdevice Status	R	I/O and Subdevice Status	R/W
WirelessHART Status	R	WirelessHART Status	R/W
AO fixed	R	AO fixed	R/W
Status group 14	R	Status group 14	R/W
Status group 15	R	Status group 15	R/W
Status group 16	R	Status group 16	R/W
Status group 17	R	Status group 17	R/W
Status group 18	R	Status group 18	R/W
Status group 19	R	Status group 19	R/W
Status group 20	R	Status group 20	R/W
<b>Alarm</b>		<b>Device reset</b>	
<b>Alarm record mask</b>		Burn out	R
	Alarm record mask 1	R/W	
	Alarm record mask 2	R/W	
	Alarm record mask 3	R/W	
<b>Alarm record</b>		Reset cfg chng flag	
	Alarm record 1	R	
	Alarm record time 1	R	
	Alarm record 2	R	
	Alarm record time 2	R	
	Alarm record 3	R	
	Alarm record time 3	R	
	Alarm record 4	R	
	Alarm record time 4	R	
<b>Alarm out mask</b>		Self test	
	Alarm out mask 1	R/W	
	Alarm out mask 2	R/W	
	Alarm out mask 3	R/W	
	Alarm out mask 4	R/W	

Device status
Process applied to the primary variable is outside the operating limits of the field device
Process applied to the non-primary variable is outside the operating limits of the field device
PV Analog Channel Saturated
PV Analog Channel Fixed
Field device has more status available
A reset or self test of the field device has occurred, or power has been removed and reapplied
A modification has been made to the configuration of the field device
Field device has malfunctioned due to a hardware error or failure

Status group 0
10:Main board CPU failure
11:Reverse calculation failure
12:Main board EEPROM failure
13:Main board EEPROM default

Status group 1
14:Sensor board failure
15:Sensor communication error
16:A/D1 failure[Signal]
17:A/D2 failure[Exciter]
18:Coil open
19:Coil short
20:Exciter failure

Status group 2
21:PWM1 stop
22:PWM2 stop
23:Option board mismatch
24:Option board EEPROM failure
25:Option board A/D failure
26:Option board SPI failure

Status group 3
27:Parameter restore incomplete
28:Indicator board failure
29:Indicator board EEPROM failure
30:LCD driver failure
31:Indicator board mismatch
32:Indicator communication error
33:microSD failure

Status group 4
50:Signal overflow
51:Empty pipe detection
52:H/L or HH/LL alarm
53:Adhesion over level 4

Status group 5
60:Span configuration error
61:PV flow select configuration error
62:Analog output 1 4-20mA limit error
63:Analog output 2 4-20mA limit error
64:Analog output 1 multi range error
65:H/L HH/LL configuration error
66:Density configuration error

Ext dev status
Maintenance required
Device variable alert
Critical Power Failure
Failure
Out of Specification
Function Check

Device Diagnostic Status 0
Simulation Active
Non-Volatile memory failure
Volatile memory error
Watchdog reset executed
Voltage conditions out of range
Environmental conditions out of range
Electronic failure
Device Configuration Locked

Device Diagnostic Status 1
Status Simulation Active
Discrete Variables Simulation Active
Event Notification Overflow

AO saturated
Secondary Analog Channel Saturated
Tertiary Analog Channel Saturated
Quaternary Analog Channel Saturated
Quinary Analog Channel Saturated

I/O and Subdevice Status
Subdevice list changed
Duplicate master detected
Subdevice mismatch
Subdevices with duplicate IDs found
Stale data notice

WirelessHART Status
Capacity Denied
Bandwidth allocation pending
Block Transfer Pending
Radio Failure

AO fixed
Secondary Analog Channel Fixed
Tertiary Analog Channel Fixed
Quaternary Analog Channel Fixed
Quinary Analog Channel Fixed

Status group 14
67:Pulse output 1 configuration error
68:Pulse output 2 configuration error
69:Nominal size configuration error
70:Adhesion configuration error
71:Flow noise configuration error
72:Data logging not started

Status group 15
80:Analog output 1 saturated
81:Analog output 2 saturated
82:Pulse output 1 saturated
83:Pulse output 2 saturated
84:Analog input saturated
85:Cable misconnect
86:Coil insulation warning
131:Transmitter type mismatch

Status group 16
87:Adhesion over level 3
88:Low conductivity warning
89:Insulation detection
90:Flow noise over level 3
91:Flow noise over level 4
92:Autozero warning
93:Verification warning
94:Factory noise warning

Status group 17
95:Simulation active
96:Analog output 1 fixed
97:Analog output 2 fixed
98:Pulse output 1 fixed
99:Pulse output 2 fixed
100:Analog input fixed

Status group 18
101:Parameter restore running
102:Display over warning
103:microSD card size warning
104:Parameter backup incomplete
105:microSD card mismatch
106:microSD card removal procedure error

Status group 19
120:Watchdog
121:Power off
122:Instant power failure
123:Parameter backup running
124:Data logging running

Status group 20
130:Device ID not entered

■ Maintenance root menu

<b>Maintenance root menu</b>		
<b>Time stamp</b>	Current Date	R/W
	Current Time	R/W
	Operation time	R
	Set Date/Time	
<b>Test</b>	→Page 232	
<b>Autozero</b>	Autozero Exe	
	Result	
	Zero value	R/W
<b>AO/AI trim</b>	<b>AO trim</b>	
		AO1 Trim
		AO2 Trim
		Clear D/A trim 1
		Clear D/A trim 2
	<b>AI trim<sup>(G)</sup></b>	
		AI Trim
		Clear AI trim
<b>High/Low alarm configuration</b>	Low alarm	R/W
	Low low alarm	R/W
	High alarm	R/W
	High high alarm	R/W
	Hi/Lo alarm hysteresis	R/W
<b>Verification</b>	→Page 232	
<b>Param bkup/restore</b>	Factory backup name	R
	Factory backup date	R
	SD backup name	R/W
	Backup Exe	
	Restore Exe	
	Backup name 1	R/W
	Backup date 1	R/W
	Backup name 2	R/W
	Backup date 2	R/W
	Backup name 3	R/W
	Backup date 3	R/W
<b>Data logging</b>	File name	R/W
	Interval time	R/W
	Start date	R
	Start time	R
	End time	R/W
	Logging Exe	R/W
	Log1 select	R/W
	Log2 select	R/W
	Log3 select	R/W
	Log4 select	R/W
<b>Display indication</b>	LCD test	R/W
	Squawk	



● Test

<b>Test</b>		
Release time	R/W	
Test mode	R/W	
<b>Input test</b>		
	Velocity	R/W
	Volume flow	R/W
	Mass flow	R/W
	Calorific value <sup>(G)</sup>	R/W
	AJ <sup>(G)</sup>	R/W
	SI3	R/W
<b>Output test</b>		
	<b>Loop test</b>	
	AO1	R/W
	Pulse1	R/W
	SO1	R/W
	AO2 <sup>(G)</sup>	R/W
	Pulse2	R/W
	SO2	R/W
	SO3	R/W
Device variable simulation		
Device status bit simulation		
Test 2 mode	R/W	
Test 2 output value	R/W	

● Verification

<b>Verification</b>		
VF target select	R/W	
Diagnostic output	R/W	
VF mode	R/W	
Verification Exe		
VF No	R/W	
<b>Result</b>		
	VF check result	R
	VF operation time	R
	Magnetic circuit result	R
	Excitation circuit result	R
	Calculation circuit result	R
	VF device status result	R
	Connection status result	R

■ Device root menu

<b>Device root menu</b>													
<b>Easy setup wizard</b>													
Volume flow	<table border="1"> <tr><td>Volume flow damping AO/frequency</td><td>R/W</td></tr> <tr><td>Volume flow damping pulse/total</td><td>R/W</td></tr> <tr><td>Volume flow unit</td><td>R/W</td></tr> <tr><td>Time unit</td><td>R/W</td></tr> <tr><td>Volume flow span</td><td>R/W</td></tr> </table>	Volume flow damping AO/frequency	R/W	Volume flow damping pulse/total	R/W	Volume flow unit	R/W	Time unit	R/W	Volume flow span	R/W		
Volume flow damping AO/frequency	R/W												
Volume flow damping pulse/total	R/W												
Volume flow unit	R/W												
Time unit	R/W												
Volume flow span	R/W												
Pulse/Status out1	<table border="1"> <tr><td>Pulse1 rate unit</td><td>R/W</td></tr> <tr><td>Pulse1 rate value</td><td>R/W</td></tr> <tr><td>Frequency1 at 0%</td><td>R/W</td></tr> <tr><td>Frequency1 at 100%</td><td>R/W</td></tr> </table>	Pulse1 rate unit	R/W	Pulse1 rate value	R/W	Frequency1 at 0%	R/W	Frequency1 at 100%	R/W				
Pulse1 rate unit	R/W												
Pulse1 rate value	R/W												
Frequency1 at 0%	R/W												
Frequency1 at 100%	R/W												
Display setting	<table border="1"> <tr><td>Display select1</td><td>R/W</td></tr> <tr><td>Display select2</td><td>R/W</td></tr> <tr><td>Display select3</td><td>R/W</td></tr> </table>	Display select1	R/W	Display select2	R/W	Display select3	R/W						
Display select1	R/W												
Display select2	R/W												
Display select3	R/W												
Autozero Exe													
<b>Basic setup</b>													
PV flow select	R/W												
Velocity check	R/W												
Velocity	<table border="1"> <tr><td>Velocity unit</td><td>R/W</td></tr> <tr><td>Velocity span</td><td>R/W</td></tr> <tr><td>Velocity damping AO/frequency</td><td>R/W</td></tr> <tr><td>Velocity damping pulse/total</td><td>R/W</td></tr> </table>	Velocity unit	R/W	Velocity span	R/W	Velocity damping AO/frequency	R/W	Velocity damping pulse/total	R/W				
Velocity unit	R/W												
Velocity span	R/W												
Velocity damping AO/frequency	R/W												
Velocity damping pulse/total	R/W												
Volume flow	<table border="1"> <tr><td>Volume flow unit</td><td>R/W</td></tr> <tr><td>Time unit</td><td>R/W</td></tr> <tr><td>Volume flow span</td><td>R/W</td></tr> <tr><td>Volume flow damping AO/frequency</td><td>R/W</td></tr> <tr><td>Volume flow damping pulse/total</td><td>R/W</td></tr> </table>	Volume flow unit	R/W	Time unit	R/W	Volume flow span	R/W	Volume flow damping AO/frequency	R/W	Volume flow damping pulse/total	R/W		
Volume flow unit	R/W												
Time unit	R/W												
Volume flow span	R/W												
Volume flow damping AO/frequency	R/W												
Volume flow damping pulse/total	R/W												
Mass flow	<table border="1"> <tr><td>Mass flow unit</td><td>R/W</td></tr> <tr><td>Time unit</td><td>R/W</td></tr> <tr><td>Mass flow span</td><td>R/W</td></tr> <tr><td>Mass flow damping AO/frequency</td><td>R/W</td></tr> <tr><td>Mass flow damping pulse/total</td><td>R/W</td></tr> </table>	Mass flow unit	R/W	Time unit	R/W	Mass flow span	R/W	Mass flow damping AO/frequency	R/W	Mass flow damping pulse/total	R/W		
Mass flow unit	R/W												
Time unit	R/W												
Mass flow span	R/W												
Mass flow damping AO/frequency	R/W												
Mass flow damping pulse/total	R/W												
Calorie <sup>(G)</sup>	<table border="1"> <tr><td>Calorific unit</td><td>R/W</td></tr> <tr><td>Time unit</td><td>R/W</td></tr> <tr><td>Calorific flow span</td><td>R/W</td></tr> <tr><td>Calorific value damping AO/frequency</td><td>R/W</td></tr> <tr><td>Calorific value damping pulse/total</td><td>R/W</td></tr> <tr><td>Specific heat</td><td>R/W</td></tr> </table>	Calorific unit	R/W	Time unit	R/W	Calorific flow span	R/W	Calorific value damping AO/frequency	R/W	Calorific value damping pulse/total	R/W	Specific heat	R/W
Calorific unit	R/W												
Time unit	R/W												
Calorific flow span	R/W												
Calorific value damping AO/frequency	R/W												
Calorific value damping pulse/total	R/W												
Specific heat	R/W												
Sensor	<table border="1"> <tr><td>Low MF</td><td>R/W</td></tr> <tr><td>High MF</td><td>R/W</td></tr> <tr><td>Flow sensor select</td><td>R/W</td></tr> <tr><td>Nominal size unit</td><td>R/W</td></tr> <tr><td>Nominal size</td><td>R/W</td></tr> </table>	Low MF	R/W	High MF	R/W	Flow sensor select	R/W	Nominal size unit	R/W	Nominal size	R/W		
Low MF	R/W												
High MF	R/W												
Flow sensor select	R/W												
Nominal size unit	R/W												
Nominal size	R/W												
User span	<table border="1"> <tr><td>User span select AO1</td><td>R/W</td></tr> <tr><td>User unit AO1</td><td>R/W</td></tr> <tr><td>User span AO1</td><td>R/W</td></tr> <tr><td>User span select AO2</td><td>R/W</td></tr> <tr><td>User unit AO2</td><td>R/W</td></tr> <tr><td>User span AO2</td><td>R/W</td></tr> </table>	User span select AO1	R/W	User unit AO1	R/W	User span AO1	R/W	User span select AO2	R/W	User unit AO2	R/W	User span AO2	R/W
User span select AO1	R/W												
User unit AO1	R/W												
User span AO1	R/W												
User span select AO2	R/W												
User unit AO2	R/W												
User span AO2	R/W												
Autozero	<table border="1"> <tr><td>Autozero Exe</td><td></td></tr> <tr><td>Zero value</td><td>R/W</td></tr> </table>	Autozero Exe		Zero value	R/W								
Autozero Exe													
Zero value	R/W												
<b>Detailed setup</b>	→Page 234												

● Detailed setup

<b>Detailed setup</b>		
Process variables	→Page 235	
<b>Sensor</b>		
	Low MF	R/W
	High MF	R/W
	Flow sensor select	R/W
	Nominal size unit	R/W
	Nominal size	R/W
<b>User span</b>		
	User span select AO1	R/W
	User unit AO1	R/W
	User span AO1	R/W
	User span select AO2 <sup>(G)</sup>	R/W
	User unit AO2 <sup>(G)</sup>	R/W
	User span AO2 <sup>(G)</sup>	R/W
Totalizer	→Page 236	
Pulse/Status	→Page 237	
Analog output/input	→Page 238	
<b>Multi range</b>		
	Forward span 2	R/W
	Reverse span 1	R/W
	Reverse span 2	R/W
	Auto range hyst	R/W
	Bi direction hyst	R/W
<b>AUX calculation</b>		
	Flow direction	R/W
	Rate limit	R/W
	Dead time	R/W
	Noise filter	R/W
	Pulsing flow	R/W
	Power synchronize	R/W
	Set power frequency	R/W
	IEX power frequency	R
	Measured power frequency	R
	Set SIL	R/W
Display	→Page 238	
Device information	→Page 239	
<b>Protection</b>		
	Write protect	R
	Enable write 10min	
	New password	
	Software seal	R

● Process variables

<b>Process variables</b>		
PV flow select		R/W
Velocity check		R/W
<b>Velocity</b>		
	Velocity unit	R/W
	Velocity span	R/W
	Velocity damping AO/frequency	R/W
	Velocity damping pulse/total	R/W
<b>Volume flow</b>		
	Volume flow unit	R/W
	Time unit	R/W
	Volume flow span	R/W
	Volume flow damping AO/frequency	R/W
	Volume flow damping pulse/total	R/W
<b>Mass flow</b>		
	Mass flow unit	R/W
	Time unit	R/W
	Mass flow span	R/W
	Mass flow damping AO/frequency	R/W
	Mass flow damping pulse/total	R/W
<b>Calorie<sup>(G)</sup></b>		
	Calorific unit	R/W
	Time unit	R/W
	Calorific flow span	R/W
	Calorific value damping AO/frequency	R/W
	Calorific value damping pulse/total	R/W
	Specific heat	R/W
<b>Density</b>		
	Density value select <sup>(G)</sup>	R/W
	Density unit	R/W
	Density fixed value	R/W
	Standard density <sup>(G)</sup>	R/W
	Correct density <sup>(G)</sup>	R
<b>Temperature<sup>(G)</sup></b>		
	Standard temperature	R/W
	Measured temperature	R
	Calorific fix temp	R/W
	Temp coef A1	R/W
	Temp coef A2	R/W

● Totalizer

<b>Totalizer</b>	
<b>Totalizer1</b>	
Total1 unit	R
Total1 conv factor	R/W
Total1 low cut	R/W
Total1 fail opts	R/W
Total1 options	R/W
Total1 Start/Stop	R/W
Total1 Reset/Preset	
Total1 preset value	R/W
Total1 set point	R/W
Total 1 count unit	R/W
<b>Totalizer2</b>	
Total2 unit	R/W
Total2 conv factor	R/W
Total2 low cut	R/W
Total2 fail opts	R/W
Total2 options	R/W
Total2 Start/Stop	R/W
Total2 Reset/Preset	
Total2 preset value	R/W
Total2 set point	R/W
Total 2 count unit	R/W
<b>Totalizer3</b>	
Total3 unit	R/W
Total3 conv factor	R/W
Total3 low cut	R/W
Total3 fail opts	R/W
Total3 options	R/W
Total3 Start/Stop	R/W
Total3 Reset/Preset	
Total3 preset value	R/W
Total3 set point	R/W
Total 3 count unit	R/W
Totalizer reset mode	R/W

● Pulse/Status

<b>Pulse/Status</b>	
<b>Pulse/Status output 1</b>	
	Pulse1 output mode R/W
	Pulse1 active mode R/W
	Pulse1 fix width R/W
	Pulse1 rate unit R/W
	Pulse1 rate value R/W
	Pulse1 low cut R/W
	Pulse1 alarm out R/W
	Frequency1 at 0% R/W
	Frequency1 at 100% R/W
	Status output1 function R/W
	Pulse1 option R/W
<b>Pulse/Status output 2</b>	
	Pulse2 active pulse R/W
	Pulse2 output mode R/W
	Pulse2 select R/W
	Pulse2 active mode R/W
	Pulse2 fix width R/W
	Pulse2 rate unit R/W
	Pulse2 rate value R/W
	Pulse2 low cut R/W
	Pulse2 alarm out R/W
	Frequency2 at 0% R/W
	Frequency2 at 100% R/W
	Status output2 function R/W
	Pulse2 option R/W
<b>Status output 3<sup>(E)</sup></b>	
	Status output3 active mode R/W
	Status output3 function R/W
<b>Status input 3</b>	
	Status input3 active mode R/W
	Status input3 function R/W
	Status input3 state R/W

● **Analog output/input**

<b>Analog output/input</b>		
Analog output 1		
AO1 low cut	R/W	
AO1 high limit	R/W	
AO1 low limit	R/W	
AO1 alarm out	R/W	
AO1 range mode	R/W	
Analog output 2 <sup>(G)</sup>		
AO2 select	R/W	
AO2 low cut	R/W	
AO2 high limit	R/W	
AO2 low limit	R/W	
AO2 alarm out	R/W	
		<b>Analog input<sup>(G)</sup></b>
		AI function
		AI high limit
		AI low limit
		AI current
		AI unit
		AI URV
		AI LRV

● **Display**

<b>Display</b>		
Line select		
Display select1	R/W	
Display select2	R/W	
Display select3	R/W	
Display select4	R/W	
Display select5	R/W	
Display select6	R/W	
Display select7	R/W	
Display select8	R/W	
Trend select		
Trend select 1	R/W	
Trend select 2	R/W	
Trend select 3	R/W	
Trend select 4	R/W	
Display format		
Display format PV	R/W	
Display format total 1	R/W	
Display format total 2	R/W	
Display format total 3	R/W	
		<b>Display operation configuration</b>
		Display contrast
		Display line
		Display period
		Display NE107
		Display alarm
		Display scroll
		Display damping
		Display format date
		Display inversion
		Language
		Language package
		Display measure mode
		Trend offline lrv
		Trend offline urv
		Display installation
		IRSW operation
		Display time

● Device information

<b>Device information</b>	
<b>Order information</b>	
	Tag R/W
	Long tag R/W
	Electrode size R/W
	Explosion protection R/W
	Basic model code R/W
	Suffix config 1 R/W
	Suffix config 2 R/W
	Option 1 R/W
	Option 2 R/W
	Option 3 R/W
	Option 4 R/W
	Remote sensor basic model code R/W
	Remote sensor suffix config 1 R/W
	Remote sensor suffix config 2 R/W
	Remote sensor option 1 R/W
	Remote sensor option 2 R/W
	Remote sensor option 3 R/W
	Remote sensor option 4 R/W
<b>Version/Number information</b>	
	Transmitter type R
	Option board ID R
	Transmitter serial No R/W
	Sensor serial No R/W
	Main board revision R
	Sensor board revision R
	Indicator board revision R
	Hardware rev R
	Dev id R
<b>IO Status</b>	
	IO1 R
	IO2 R
	IO3 R
	IO4 R
<b>Memo</b>	
	Memo 1 R/W
	Memo 2 R/W
	Memo 3 R/W
<b>HART setup</b>	
	Poll addr R/W
	Loop current mode R/W
	Num req preams R
	Num resp preams R/W
	Manufacturer R
	Model R
	Date R/W
	Descriptor R/W
	Message R/W
	Distributor R
	Final asmbly num R/W
	Max dev vars R
	Device Profile R
	Universal rev R
	Fid dev rev R
	Software rev R
	Hardware rev R
	PV unit R/W
	Burst setup →Page 240
	Event setup →Page 241



● Burst setup

<b>Burst setup</b>	
Stop burst	
Easy burst setup	
	Set easy burst
	Stop easy burst
	Burst mode R
	Burst Command R
	slot0 R
	slot1 R
	slot2 R
	slot3 R
<b>Detailed burst setup</b>	
	set Detailed Burst
	stop Detailed Burst
	<b>BM1 Setting</b>
	Burst mode R
	Burst Command R
	slot0 R
	slot1 R
	slot2 R
	slot3 R
	slot4 R
	slot5 R
	slot6 R
	slot7 R
	Update Period R
	Max Update Period R
	Burst Msg Trigger Mode R
	Burst Trigger Class R
	Burst Trigger Units R
	Burst Trigger Level R
	<b>BM2 Setting</b>
	Burst mode R
	Burst Command R
	slot0 R
	slot1 R
	slot2 R
	slot3 R
	slot4 R
	slot5 R
	slot6 R
	slot7 R
	UpdatePeriod R
	Max Update Period R
	Burst Msg Trigger Mode R
	Burst Trigger Class R
	Burst Trigger Units R
	Burst Trigger Level R
	<b>BM3 Setting</b>
	Burst mode R
	Burst Command R
	slot0 R
	slot1 R
	slot2 R
	slot3 R
	slot4 R
	slot5 R
	slot6 R
	slot7 R
	UpdatePeriod R
	Max Update Period R
	Burst Msg Trigger Mode R
	Burst Trigger Class R
	Burst Trigger Units R
	Burst Trigger Level R

● Event setup

Event setup	
set Event	
stop Event	
acknowledge Event	
Event Setting	
Event Notification Control	R
Event Notification Retry Time	R
Max Update Time	R
Event Debounce Interval	R
Event Status	R
Time First unack Event Triggered	R
Device Status Mask	R
Ext dev status Mask	R
Device Diagnostic Status 0 Mask	R
Device Diagnostic Status 1 Mask	R
Device Diagnostic Status 2 Mask	R
Device Diagnostic Status 3 Mask	R
AO fixed Mask	R
AO saturated Mask	R
Device Specific Status 0 Mask	R
Device Specific Status 1 Mask	R
Device Specific Status 2 Mask	R
Device Specific Status 3 Mask	R
Device Specific Status 4 Mask	R
Device Specific Status 5 Mask	R
Device Specific Status 14 Mask	R
Device Specific Status 15 Mask	R
Device Specific Status 16 Mask	R
Device Specific Status 17 Mask	R
Device Specific Status 18 Mask	R
Device Specific Status 19 Mask	R
Device Specific Status 20 Mask	R

# Revision Information

- Title : ADMAG TI Series AXG, AXW Magnetic Flowmeter HART Communication Type
- Manual No. : IM 01E21A02-02EN

Edition	Date	Page	Revised Item
1st	Nov. 2020	—	New publication
2nd	Mar. 2021	14 117 141, 142 225, 228, 232	2.2.1 Correction of errors. 4.8.6 Correction of errors. 4.11.6 Correction of errors. 6.2 Correction of errors.
3rd	Dec. 2021	31 137 160	3.6.1 Add the description of process variable setting. 4.11.2 Add NOTE, and the description of setting procedure. 4.13.3 Correction of errors.
4th	Mar. 2023	45 48 86	4.1.5 Add NOTE. 4.1.7 Add NOTE. 4.6.4 Add NOTE.
5th	Jul. 2024	65	4.3.4 Add NOTE.