

**Model FLXA402  
4-Wire Converter  
Installation and Wiring  
(Introduction and General Description)**

IM 12A01F01-02EN

---

# ◆ Introduction

Thank you for purchasing the FLXA™ 402 4-Wire Converter.

This Instructor's Manual contains all essential information for the user to make full use of FLXA402.

Please read the following respective documents before installing and using the FLXA402.

The related documents are listed as follows.

## General Specifications

Contents	Document number	Note
FLXA402 4-Wire Converter	GS 12A01F01-01EN	Online manual

"EN" in the document number is the language code.

## User's Manual

Contents	Document number	Note
FLXA402 4-Wire Converter Start-up and Safety Precautions	IM 12A01F01-01EN	Attached to the product (printed manual)
FLXA402 4-Wire Converter Installation and Wiring	IM 12A01F01-02EN	Online manual (This manual)
FLXA402 4-Wire Converter Operation of Converter	IM 12A01F01-03EN	Online manual
FLXA402 4-Wire Converter Operation of pH/ORP	IM 12A01F02-01EN	Online manual
FLXA402 4-Wire Converter Operation of SC	IM 12A01F03-01EN	Online manual
FLXA402 4-Wire Converter Operation of ISC	IM 12A01F04-01EN	Online manual
FLXA402 4-Wire Converter Operation of DO	IM 12A01F05-01EN	Online manual

"EN" in the document number is the language code.

An exclusive User's Manual might be attached to the products whose suffix codes or option codes contain the code "Z" (made to customers' specifications). Please read it along with this manual.

## Technical Information

Contents	Document number	Note
FLXA402 4-Wire Converter HART communication	TI 12A01F01-61EN	Online manual
FLXA402 4-Wire Converter MODBUS communication	TI 12A01F01-62EN	Online manual

"EN" in the document number is the language code.

You can download the latest documents from our website. Scan QR code.

<http://www.yokogawa.com/an/flxa402/download/>



## ■ Notes on Handling User's Manuals

- Please hand over the user's manuals to your end users so that they can keep the user's manuals on hand for convenient reference.
- Please read the information thoroughly before using the product.
- The purpose of these user's manuals is not to warrant that the product is well suited to any particular purpose but rather to describe the functional details of the product.
- No part of the user's manuals may be transferred or reproduced without prior written consent from YOKOGAWA.
- YOKOGAWA reserves the right to make improvements in the user's manuals and product at any time, without notice or obligation.
- If you have any questions, or you find mistakes or omissions in the user's manuals, please contact our sales representative or your local distributor.

## ■ Drawing Conventions

Some drawings may be partially emphasized, simplified, or omitted, for the convenience of description.

Some screen images depicted in the user's manual may have different display positions or character types (e.g., the upper / lower case). Also note that some of the images contained in this user's manual are display examples.

## ■ Composition of this User's Manual

FLXA402, a modular-designed converter, is a multi-parameter instrument offering a wide range of measurement choices; such as: pH/ORP (oxidation-reduction potential), Resistivity/Conductivity (SC), Inductive conductivity (ISC), Dissolved Oxygen (DO) – with the respective sensor module.

This user's manual contains general description and precautions of the instrument.

The table below shows user's manuals to read concerning the instrument's operation, configuration, or calibration, which vary depending on its installation, wiring, and specification of each instrument.

Contents	pH/ORP SENCOM™ SA	Contacting conductivity (SC) SENCOM SA	Inductive conductivity (ISC)	Dissolved oxygen (DO)
Introduction and general description	IM 12A01F01-02EN (this manual)			
Wiring and installation	IM 12A01F01-02EN (this manual)			
Converter operation (Setting, Calibration) Maintenance, Troubleshooting	IM 12A01F01-03EN			
Sensor operation (Setting, Calibration)	IM 12A01F02-01EN	IM 12A01F03-01EN	IM 12A01F04-01EN	IM 12A01F05-01EN

## ■ Trademark Acknowledgments

- FLEXA, FLXA, SENCOM and FieldMate are trademarks or registered trademarks of Yokogawa Electric Corporation.
- All other company and product names mentioned in this user's manual are trademarks or registered trademarks of their respective companies.
- We do not use TM or ® mark to indicate those trademarks or registered trademarks in this user's manual.

# ◆ Regulatory Compliance for Radio and Telecommunication

## ● FCC Approval

### FCC CAUTION

Changes or modifications not expressly approved by the party responsible for compliance could void the user's authority to operate the equipment.

Note: This equipment has been tested and found to comply with the limits for a Class A digital device, pursuant to part 15 of the FCC Rules. These limits are designed to provide reasonable protection against harmful interference when the equipment is operated in a commercial environment. This equipment generates, uses, and can radiate radio frequency energy and, if not installed and used in accordance with the instruction manual, may cause harmful interference to radio communications. Operation of this equipment in a residential area is likely to cause harmful interference in which case the user will be required to correct the interference at his own expense.

This transmitter must not be co-located or operated in conjunction with any other antenna or transmitter.

This equipment complies with FCC radiation exposure limits set forth for an uncontrolled environment and meets the FCC radio frequency (RF) Exposure Guidelines. This equipment has very low levels of RF energy that it deemed to comply without maximum permissive exposure evaluation (MPE).

## ● IC Approval

This Class A digital apparatus complies with Canadian ICES003.

Cet appareil numérique de la classe A est conforme à la norme NMB-003 du Canada.

This device complies with Industry Canada's applicable license-exempt RSSs. Operation is subject to the following two conditions:

- (1) this device may not cause interference; and
- (2) this device must accept any interference, including interference that may cause undesired operation of the device.

Le présent appareil est conforme aux CNR d'Industrie Canada applicables aux appareils radio exempts de licence.

L'exploitation est autorisée aux deux conditions suivantes:

- (1) l'appareil ne doit pas produire de brouillage;
- (2) l'utilisateur de l'appareil doit accepter tout brouillage radioélectrique subi, même si le brouillage est susceptible d'en compromettre le fonctionnement.

This equipment complies with IC radiation exposure limits set forth for an uncontrolled environment and meets RSS-102 of the IC radio frequency (RF) Exposure rules. This equipment has very low levels of RF energy that it deemed to comply without maximum permissive exposure evaluation (MPE). [\*But it is desirable that it should be installed and operated keeping the radiator at least 20cm or more away from person's body.]

Cet équipement est conforme aux limites d'exposition aux rayonnements énoncées pour un environnement non contrôlé et respecte les règles d'exposition aux fréquences radioélectriques (RF) CNR-102 de l'IC. Cet équipement émet une énergie RF très faible qui est considérée comme conforme sans évaluation de l'exposition maximale autorisée (MPE).

[\*Cependant, il est souhaitable qu'il devrait être installé et utilisé en gardant une distance de 20 cm ou plus entre le radiateur et le corps humain.]

---

- **RE Directive**

When FLXA402 contains Bluetooth communication, FLXA402 is built in compliance with requirements of RE Directive:

We, Yokogawa Electric Corporation hereby declare that this equipment, FLXA402 is in compliance with the essential requirements and other relevant provisions of Directive 2014/53/EU. The full text of the EU declaration of conformity is available at the following internet address:

<http://www.yokogawa.com/an/flxa402/download/>

- **Singapore IMDA Approval**

FLXA402 complies with IMDA Standards.

Complies with IMDA Standards DA102687
---

# Control Drawings

## FM Nonincendive

Yokogawa Electric Corporation			Model		FLXA402		
Title	Control drawing						
No.	NFM038-A81	Page	01	Revision	0	Date	2018-06-29

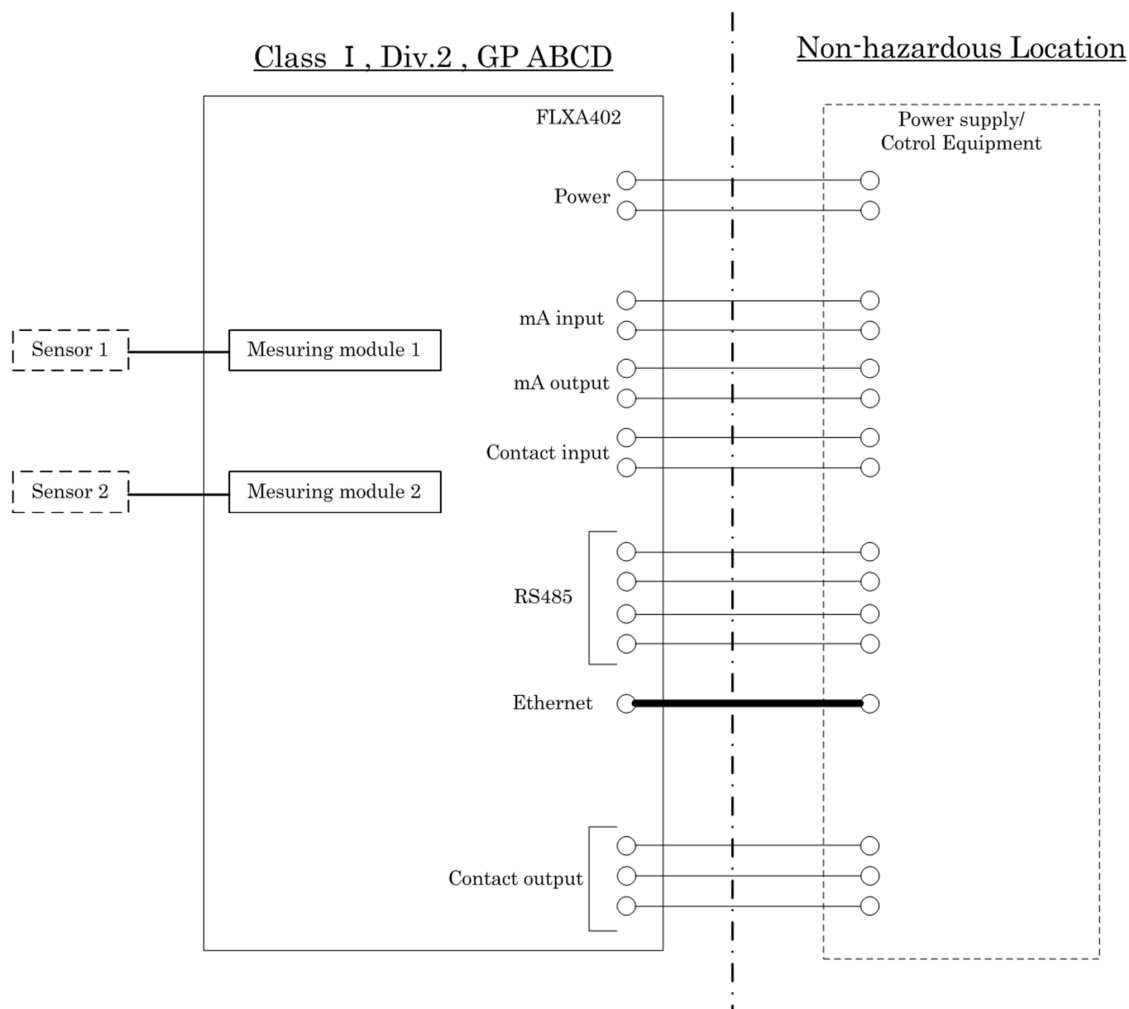

Measuring Module 1, 2 NIFW parameter

	Type of Measuring Module			
	PH	SC	ISC	SENCOM SA
U <sub>o</sub>	11.76V	11.76V	11.76V	5.36V
I <sub>o</sub>	116.5mA	116.5mA	60.6mA	106.16mA
P <sub>o</sub>	0.3424W	0.3424W	0.178W	0.1423W
C <sub>o</sub>	4 $\mu$ F	4 $\mu$ F	4 $\mu$ F	31 $\mu$ F
L <sub>o</sub>	4.5mH	4.5mH	19mH	0.45mH

Yokogawa Electric Corporation			Model	FLXA402			
Title	Control drawing						
No.	NFM038-A81	Page	02	Revision	0	Date	2018-06-29

## Spec. restriction

Temp. class	Power supply	Number of mA Output	Ambient Temperature		Switch capacity of Contact Output	
			-20 to +55°C	-20 to +40°C	MAX. 5A	MAX. 4A
T4	AC version 100-240V AC	2	✓		✓	
		4	✓			✓
	DC version 12-24V DC	2	✓		✓	
		4	✓			✓
T6	AC version 100-120V AC	2		✓	✓	
		4		✓		✓
	DC version N/A					

## Notes:

- No revision to this drawing without prior approval of FM.
- Installation must be in accordance with the National Electrical Code (NFPA 70), ANSI/ISA-RP12.06.01 and relevant local codes.
- When installed in Division 2, Sensor 1 and Sensor 2 may be simple apparatus or nonincendive field wiring apparatus meeting the conditions below, or alternatively, they may be equipment suitable for Division 2 respectively, if a suitable wiring method other than nonincendive field wiring is employed.

$$U_i \geq U_o$$

$$I_i \geq I_o$$

$$P_i \geq P_o$$

$$C_i \leq C_o - C_{\text{cable}}$$

$$L_i \leq L_o - L_{\text{cable}}$$

- WARNING—EXPLOSION HAZARD. DO NOT OPEN WHILE THE EQUIPMENT IS ENERGIZED OR WHEN AN EXPLOSIVE ATMOSPHERE IS PRESENT.
- WARNING—EXPLOSION HAZARD. DO NOT REMOVE OR REPLACE THE FUSE WHILE THE EQUIPMENT IS ENERGIZED OR WHEN AN EXPLOSIVE ATMOSPHERE IS PRESENT.
- WARNING—SUBSTITUTION OF COMPONENTS MAY IMPAIR SUITABILITY FOR DIVISION 2.

**Model FLXA402****4-Wire Converter****Installation and Wiring (Introduction and General Description)**

IM 12A01F01-02EN 11th Edition

**CONTENTS**

◆	Introduction.....	i
◆	Regulatory Compliance for Radio and Telecommunication .....	iii
◆	Control Drawings .....	v
1.	<b>INTRODUCTION AND GENERAL DESCRIPTION.....</b>	<b>1-1</b>
1.1	Instrument check .....	1-2
1.2	Name and description .....	1-6
1.3	Specification.....	1-8
1.4	Model & Suffix Codes .....	1-9
1.5	Dimensions.....	1-10
2.	<b>WIRING AND INSTALLATION .....</b>	<b>2-1</b>
2.1	Installation site .....	2-1
2.2	Mounting methods.....	2-2
2.3	Removing the shield cover .....	2-3
2.4	Installing the cable glands .....	2-4
2.5	Wiring .....	2-6
2.5.1	Wiring the power supply.....	2-7
2.5.2	Wiring relay module (Contact outputs) .....	2-10
2.5.3	Wiring network cables.....	2-12
2.5.4	Wiring IO module .....	2-13
2.6	<b>Sensor wiring .....</b>	<b>2-15</b>
2.6.1	Wiring the pH/ORP sensor .....	2-18
2.6.2	Wiring the conductivity (SC) sensor.....	2-20
2.6.3	Wiring the inductive conductivity (ISC) sensor .....	2-21
2.6.4	Wiring the dissolved oxygen (DO) sensor .....	2-21
2.6.5	Wiring digital sensors.....	2-22
2.6.6	Wiring sensors with SENCOM SA.....	2-24
	<b>Customer Maintenance Parts List.....</b>	<b>CMPL 12A01F01-01EN</b>
	<b>Revision Record.....</b>	<b>i</b>





---

# 1. INTRODUCTION AND GENERAL DESCRIPTION

The FLXA402 can work with the existing analog sensors\*1 (pH/ORP, conductivity, inductive conductivity, and dissolved oxygen).

The FLXA402 can additionally work with the SA11 SENCOM™ Smart Adapter and its dedicated sensors to provide measurements with digital sensors and multiple sensor connections\*2 of up to 5 sensors.

For the transfer of diagnostic data and other device information to a host system, the FLXA402 supports the HART and MODBUS protocols. This solution also facilitates connection to the cloud and the construction of an Industrial IoT (IIoT) environment, for improved field maintenance.

For further information, see GS 12A01F01-01EN.

This manual describes how to use the FLXA402 with Yokogawa's or other companies' sensors. Please read carefully this manual and the instruction manuals relevant to those sensors you use before using this instrument.

\*1: Analog sensors here represent sensors , PH8E□P, SC4AJ, ISC40GJ, DO30G etc., which are connectable when Model and Suffix codes -P1, -C1, -C5, -D1 are specified in 1st or 2nd input. However, when Type is "-DD" (NI for FM), -D1 (DO) cannot be selected.

\*2: When -S5 on 1st input is specified, up to 4 pH or SC sensors equipped with SA11 can be connected with a connection to BA11 Junction Box. However, when Type is -DD (NI for FM), -S5 (SENCOM SA) cannot be selected. (1st/2nd input)

# 1.1 Instrument check

Upon delivery, unpack the instrument carefully and inspect it to ensure that it was not damaged during shipment. If damage is found, retain the original packing materials (including the outer box) and then immediately notify the carrier and the relevant Yokogawa sales office.

## ■ Checking the model and suffix code

Make sure the model and suffix code on the nameplate affixed to the left side of the housing. Refer to 1.4 Model & Suffix Codes

Apply correct power identified on the nameplate to the unit.

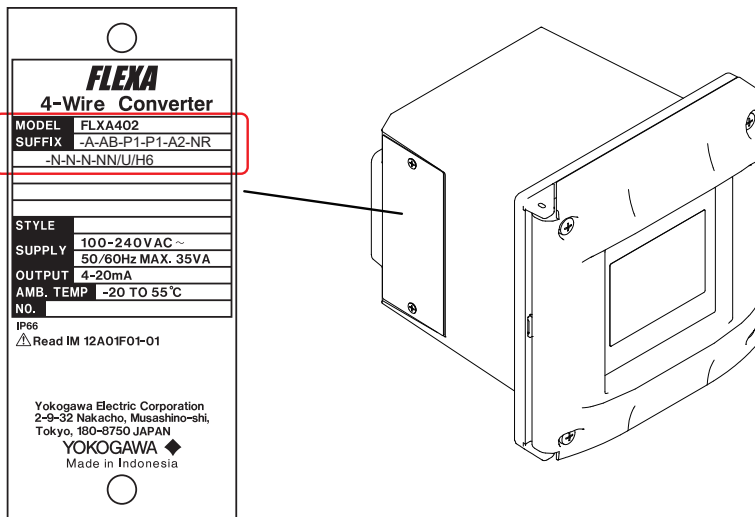

Figure 1.1 Example of nameplate (FLXA402)

You find the model, style, and serial number of the product inside of the front panel, but no description of the power supply.

## ■ Mark position of FM nonincendive

When selecting the nonincendive model (suffix code Type : -DD), make sure the FM nonincendive information on the standard nameplate affixed to the right side of the housing.

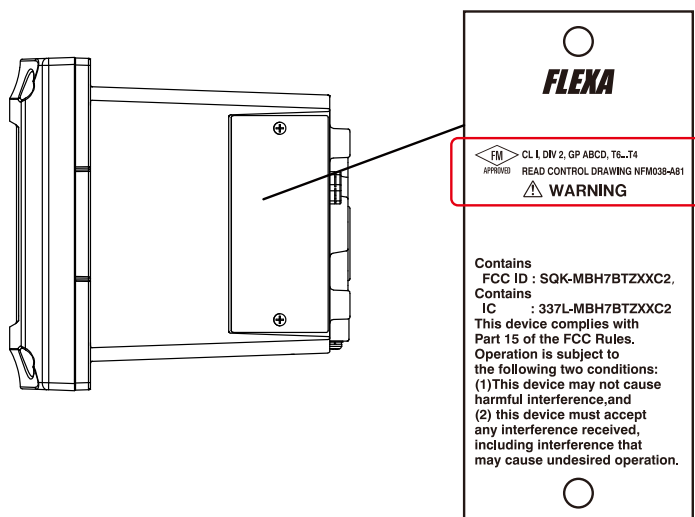

Figure 1.2

■ Spare parts

Spare parts are supplied by Yokogawa with the product. Make sure items in Table 1.1 are included.

Table 1.1 Spare parts





Product Name	Model and suffix code	Quantity	Remark
Cable glands 	all others except the one below	Cable gland (M20x1.5): 8 pcs Rubber plug attachment : 5 pcs	
	digital communication: -E (Modbus TCP/IP)	Cable gland (M20x1.5): 7 pcs Ethernet cable gland (black): 1 piece Rubber plug attachment (black): 5 pcs	
Grommet set 	1st input: -P1(pH/ORP)	1set	
	2nd input: -P1(pH/ORP)	1set	
Grommet 	1st input: , -S5 (SENCOM SA)	1 piece	
	2nd input: -S5 (SENCOM SA)	1 piece	
	1st input: , -D6 (Digital sensor)	1 piece	For DO71
Jumper 	1st input: -P1(pH/ORP)	2 pcs	
	2nd input: -P1(pH/ORP)	2 pcs	
	digital communication: -R (Modbus RTU(RS-485))	1 piece	For terminating resistor
Start-up Manual IM 12A01F01-01EN	All	1 book	

Table 1.2 Options (option code)

Product Name	Model and suffix code	Quantity	Remark
Pipe and wall mounting hardware 	Option code: /UM, /U	1 set	For /UM, bracket for /U and /PM, one of each, are supplied.
Panel mounting hardware 	Option code: /UM, /PM	1 set	
Hood 	Option code: /H6, /H7	1 set	
Stainless steel tag plate 	Option code: /SCT	1 set Stainless steel tag plate wire	User-specified tag number is printed.
Tag plate 	when other than /SCT is specified with a print order of tag plate number.	1 piece	User-specified tag number is printed.

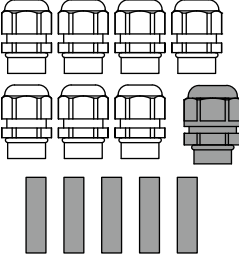
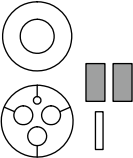
Product Name	Model and suffix code	Quantity	Remark
Conduit adapter 	Option code: /CB4, /CD4, / CF4	Adapter: 4 pcs Cable gland for adapter: 4 pcs Rubber plug attachment : 1 piece	
	/CB6, /CD6, / CF6	Adapter: 3 pcs Cable gland for adapter: 3 pcs Ethernet adapter: 1 piece Ethernet cable gland (black): 1 piece Rubber plug attachment 1 piece	

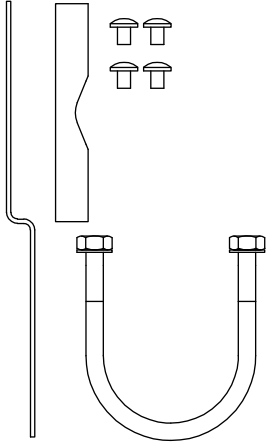
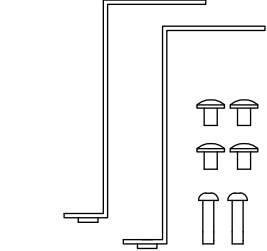
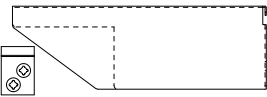
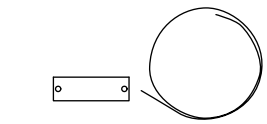
Parts to be purchased separately are not listed here. For information on accessories to be purchased separately, see 1-10 ● Conduit adapter (need to be purchased additionally)

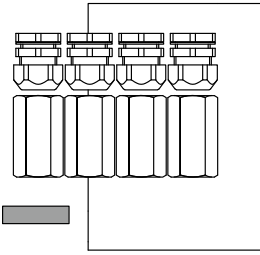
# 1.2 Name and description

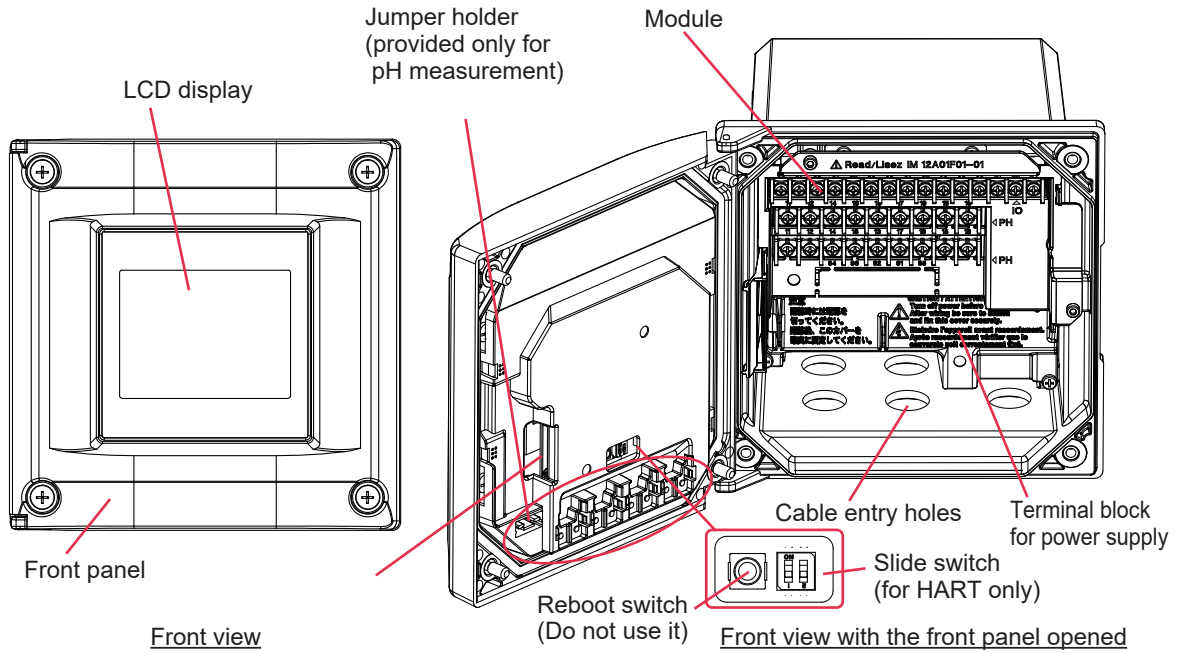

Figure 1.3 FLXA402 Parts names and descriptions

## CAUTION

Slide switch 1 is for HART. See the technical information TI 12A01F01-61EN for the technical information.

Do not switch ON the Slide switch 2. Do not press reboot switch, either.

FLXA 402 is a module-designed converter, assigning each function to separate module. The figure below shows how modules are installed, although modules to use are different according to specification.

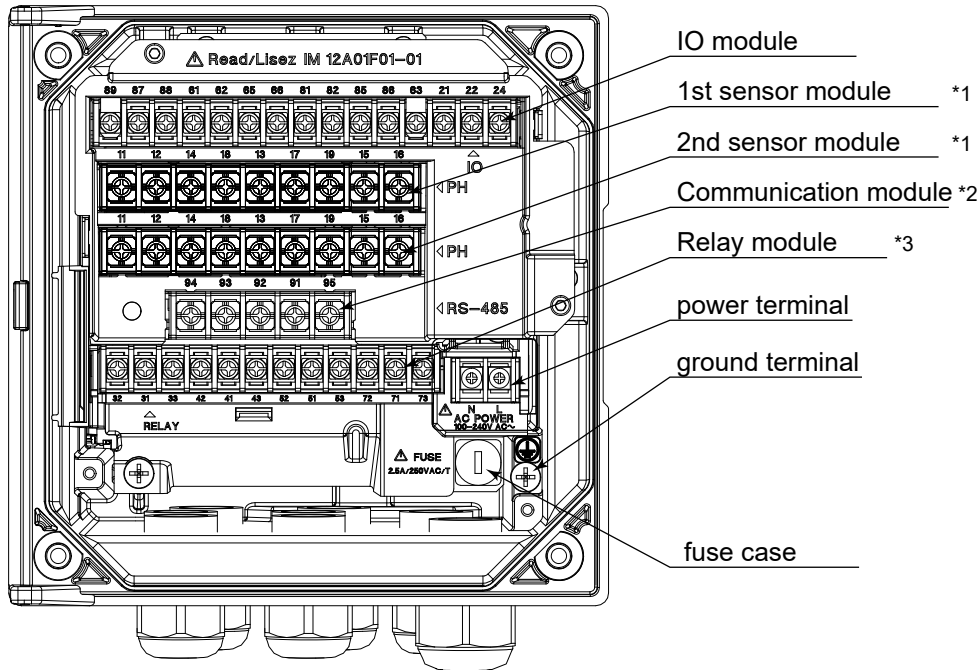

Figure 1.4

\*1: Model and Suffix Code specified for 1st/2nd sensor module defines what is printed on the shield cover, next to the sensor module. Figure 1.5 shows an example of selecting -P1 for both modules. The following list shows what is printed according to MS code.

- P1: PH
- C1: SC
- C5: ISC
- D1: DO
- D5, -D6: DIGITAL SENSOR (cannot select for 2nd sensor module)
- S5: SENCOM SA
- NN: (selectable for only 2nd input. No 2nd sensor module. )

\*2: An example when -R (Modbus RTU) is specified.  
The next figure shows an example when -E (Modbus TCP/IP) is specified.

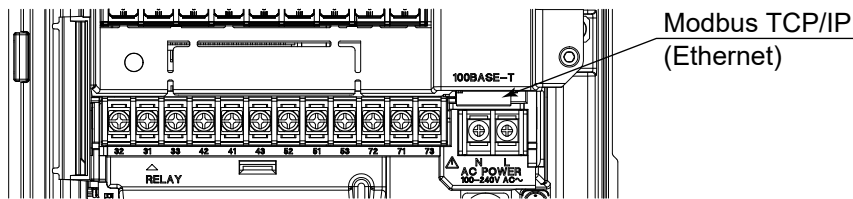

Figure 1.5 FLXA 402 Module installation (example, without shield cover)

\*3: An example when -WR (Contact outputs) for Contact Outputs is specified.



- **Jumper and Jumper holder**

When you don't need the jumpers, store them in the jumper holders located inside of the front panel, to prevent them from being lost.

You can put jumpers anywhere among 5 holders (1A and 4Bs) as Figure 1.6.

A has a guide hole. B has clicks on both side of each holder.

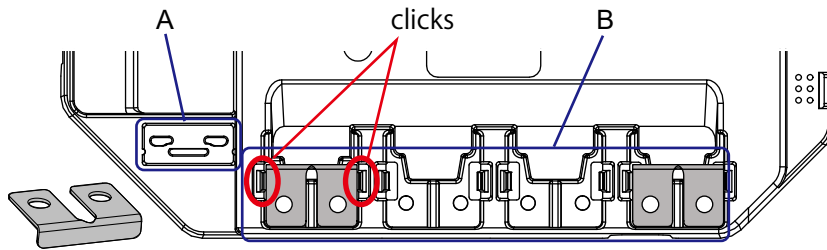

Figure 1.6 Jumper holders

## 1.3 Specification

See the latest specification. GS 12A01F01-01EN

# 1.4 Model & Suffix Codes

Model	Suffix code	Option code	Description
FLXA402			4-Wire Converter
Power supply	-A -D		AC version DC version
Housing (*1)	-B -D		Aluminum alloy cast + urethane coating Aluminum alloy cast + high anti-corrosion coating
Type	-AB -AD -AG -AJ -AQ -AR -DD		General purpose for CE, RCM, China standard General purpose for CSA General purpose for KC General purpose General purpose for EAC with PA (*10) General purpose for EAC (*10) NI for FM (*8)
1st input (*9)	-P1 -C1 -C5 -D1 -D5 -D6 -S5		pH/ORP (PH) Conductivity (SC) Inductive conductivity (ISC) Dissolved oxygen (DO) Digital sensor (*11) Digital sensor (DO71, DO72) SENCOM SA (*2)
2nd input (*9)	-NN -P1 -C1 -C5 -D1 -S5		Without input pH/ORP (PH) Conductivity (SC) Inductive conductivity (ISC) Dissolved oxygen (DO) SENCOM SA (*3)
mA Output/Input	-A2 -A4		2 x 4-20 mA Output + 1 x Contact Input (mA1 output: with HART) 4 x 4-20 mA Output + 2 x Contact Input + 1 x 4-20 mA Input (mA1 output: with HART)
Contact Outputs	-WR -NR		Contact outputs Without Contact outputs
Bluetooth	-N -B		Without Bluetooth Bluetooth
Digital Communication	-N -E -R		Without Digital communication Modbus TCP/IP Modbus RTU (RS-485)
Country (*4)	-N -J		Global except Japan Japan
—	-NN		Always -NN
Option	Mounting hardware Hood Tag plate Conduit adapter (*7)	/UM /U /PM /H6 /H7 /SCT /CB4 /CD4 /CF4 /CB6 /CD6 /CF6	Universal mounting kit (*5) Pipe and wall mounting hardware Panel mounting hardware Hood, stainless steel Hood, stainless steel + urethane coating Stainless steel tag plate G1/2 x 4 pcs 1/2NPT x 4 pcs M20 x 1.5 x 4 pcs G1/2 x 3 pcs + G 1/2 for Ethernet x 1 pcs (*6) 1/2NPT x 3 pcs + 1/2 NPT for Ethernet x 1 pcs (*6) M20 x 1.5 x 3 pcs + M20 for Ethernet x 1 pcs (*6)

- \*1. Urethane coating is for acid resistance. For high anti-corrosion coating, urethane coating and epoxy coating which is for alkali resistance are applied.
- \*2. On 1st input, with a connection to BA11 Junction Box, up to 4 sensors equipped with SA11 can be connected except when Type “-DD” (NI for FM) is selected. When Type “-DD” (NI for FM) is selected, only 1 sensor equipped with SA11 can be connected. BA11 cannot be used.
- \*3. On 2nd input, only 1 sensor equipped with SA11 can be connected.
- \*4. Select only “-J” if you use the converter in Japan. Only SI unit (International System of Units) applies.
- \*5. Universal mounting kit contains pipe, wall mounting hardware (/U) and panel mounting hardware (/PM).
- \*6. Available only when “-E” (Modbus TCP/IP) via digital communication is selected.
- \*7. There are 8 cable entry holes. Check the table below. If you need, purchase the adapters additionally to comply with requirements in the specification.

Spec.	Power	1st input	2nd input		mA output/input		Contact Outputs		Digital Communication		
Code	All	All	-NN	the others	-A2	-A4	-WR	-NR	-N	-E	-R
Required No. of cable entry holes	1	1	0	1	1	2	2	0	0	1*	1

- \*: Conduit exclusively for Ethernet
- \*8. When selecting Type “-DD” (Nonincendive for FM), “-D1” “-D5” “-D6” on 1st/2nd input are not available. When selecting “-S5” as 1st/2nd input, select SA11 “-CD” (IS for FM-US, FM-Canada). Please check Control Drawing about the other conditions.

- \*9. When you select both 1st and 2nd inputs, prepare a sensor for each input. If you do not connect the sensor, an alarm will occur.
- \*10. When selecting Type "-AQ" or "-AR" (General purpose for EAC with PA or EAC), "-D6" on 1st input are not available.
- \*11. -D5 module can connect DO70G or equivalent product. DO70G can't be sold in Europe, Korea, Australia, New Zealand and some area. Please contact to local sales office about details.

● **Conduit adapter (need to be purchased additionally)**

Type	Parts number	Quantity	Remark
G 1/2 (Cable gland for adapter + adapter)	K9703WF	4 set	for Option code /CB
1/2 NPT (Cable gland for adapter + adapter)	K9703WG	4set	for Option code /CD□
M 20 x 1.5 (Cable gland for adapter + adapter)	K9703WH	4 set	for Option code /CF□

● **Optional parts**

Name		Parts number	Quantity	Remark
Mounting hardware	for pipe, wall mounting (stainless)	K9703SS	1 set	same as Option code /U
	for panel mounting (stainless)	K9703ZD	1 set	same as Option code /PM
Sun shade hood	Stainless	K9698WK	1 set	same as Option code /H6
	stainless + urethane	K9698WL	1 set	same as Option code /H7
Rubber plug attachment		K9334CN	1 pcs	for Cable gland
Fuse		A1633EF	1 pcs	250V/2.5A (minimum 5 pcs)
SD card		A1019NL	1 pcs	2 GB industrial SD card Customers can provide the cards with spec: Storage capacity: 128 MB or greater Type: SD, SDHC (with power failure recovery)

**NOTE**

SD cards are supplied by users if necessary. For further information, see 5.1 in IM 12A01F01-03EN.

## 1.5 Dimensions

See the latest General Specification: GS 12A01F01-01EN.

---

## 2. WIRING AND INSTALLATION

Install the cable glands on FLXA402 before wiring. The cable glands are included inside the product package.

### 2.1 Installation site

The FLXA402 is weatherproof and can be installed both indoors and outdoors. It should, however, be installed as close as possible to the sensor to avoid long cable runs between the instrument and sensor.

Select an installation site where the ambient temperature and humidity are within the limits of the instrument specifications as below. If the instrument is installed outdoors and exposed to direct sunlight, a sun shade hood should be used.

Ambient Operating Temperature: -20 to +55 °C

Storage Temperature: -30 to +70 °C

Humidity: 10 to 90% RH at 40°C (Non-condensing)

Select an installation site that meets the following conditions.

- Mechanical vibrations and shocks are negligible.
- No relay switch and power switch are installed close to the converter.
- There is space for cable connection beneath the cable glands.
- Not exposed to direct sunlight or severe weather conditions.
- Maintenance is possible.
- No corrosive atmosphere.

## 2.2 Mounting methods

See 1.5Dimensions for information on the hardware for mounting.

The FLXA402 has various mounting possibilities.(Figure 2.1)

- Panel mounting using optional mounting hardware (/PM or /UM)
- Wall mounting using optional mounting hardware (/U or /UM)
- Pipe mounting using optional mounting hardware (/U or /UM) on a horizontal or vertical pipes (Nominal size: 50A)

The universal mounting kit (/UM) contains the pipe and wall mounting hardware (/U) and the panel mounting hardware (/PM). Some can be left unused.

### Panel mounting

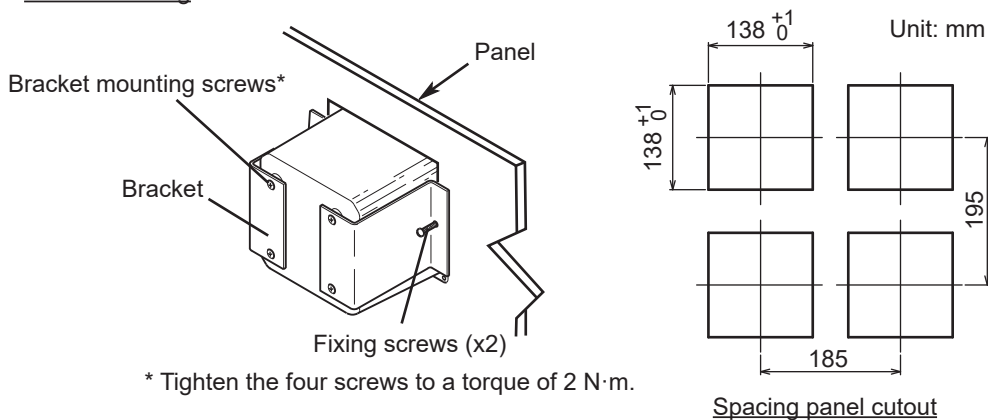

\* Tighten the four screws to a torque of 2 N·m.

### Wall mounting

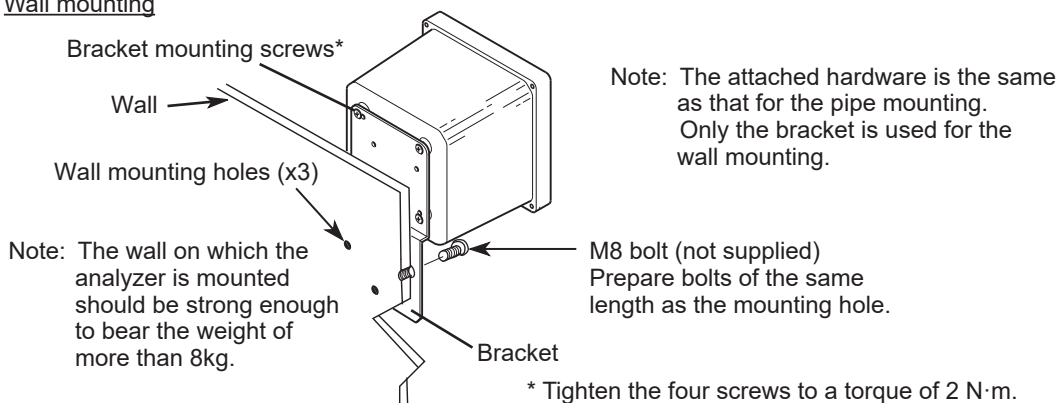

Note: The attached hardware is the same as that for the pipe mounting. Only the bracket is used for the wall mounting.

### Pipe mounting

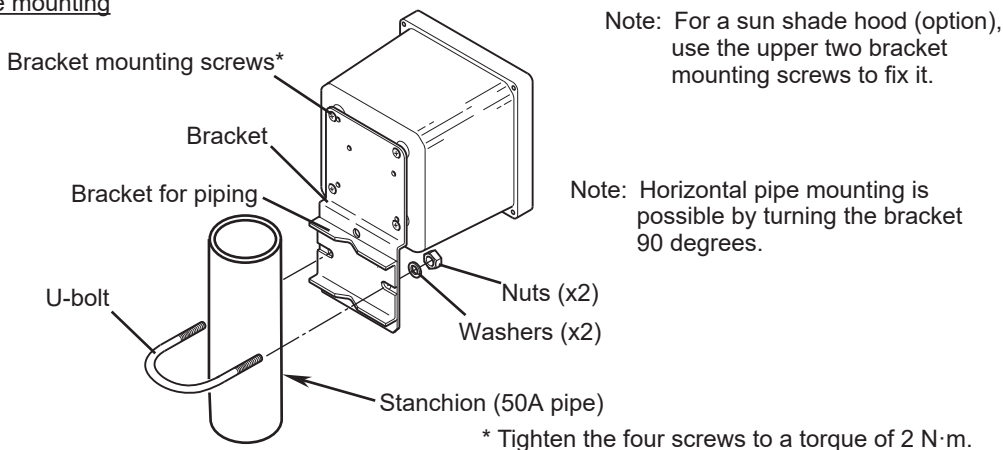

Figure 2.1 Three types of mounting with the optional mounting hardware

When you change the mounting type, you can order mounting hardware optionally. For further information see ● Optional parts

## 2.3 Removing the shield cover

The shield cover covers high-voltage power supply terminals and relay modules.

### CAUTION

To ensure your safety, be sure to shut down the power supply before you remove the shield cover.

Open the front panel and remove the shield cover. After removing the shield cover, install the cable glands.

To remove the shield cover, loosen the 2 screws at  $\Delta$  (triangle). Pull out the shield cover by holding the marked point  $\circ$  (circle) (Figure 2.2).

### NOTE

Be careful not to lose the shield cover screws.

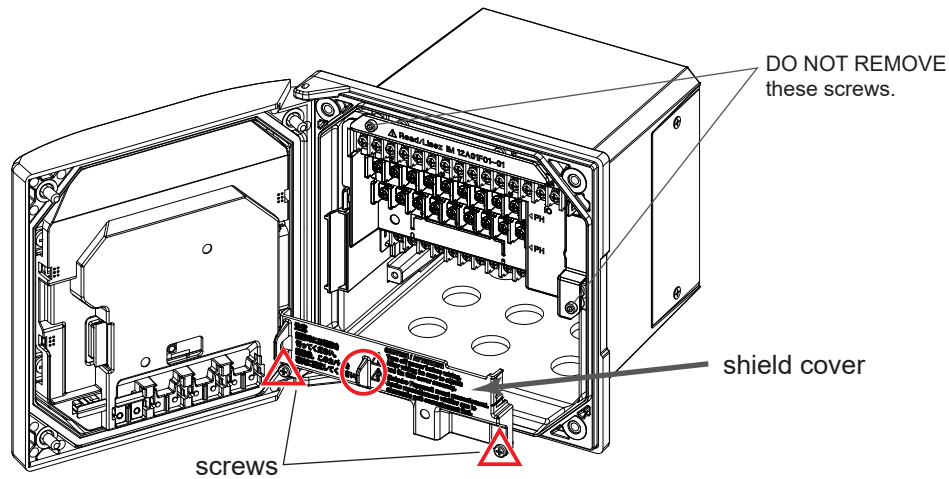

Figure 2.2

Figure 2.2

Shield cover

## 2.4 Installing the cable glands

The supplied cable glands are for cables with an outside diameter of 6 to 12 mm (0.24 to 0.47 inches). Unused cable entry holes must be sealed with cable glands including the supplied rubber close up plugs.

When the suffix code for Digital Communication code is -E (Modbus TCP/IP), apply cable glands (black) for Ethernet to the holes on the modules for communication.

For installing conduit adapters, apply Conduit adapter set (need to be purchased additionally, see ● Conduit adapter (need to be purchased additionally) ● Conduit adapter (need to be purchased additionally) and follow the instruction shown on Figure 2.5.

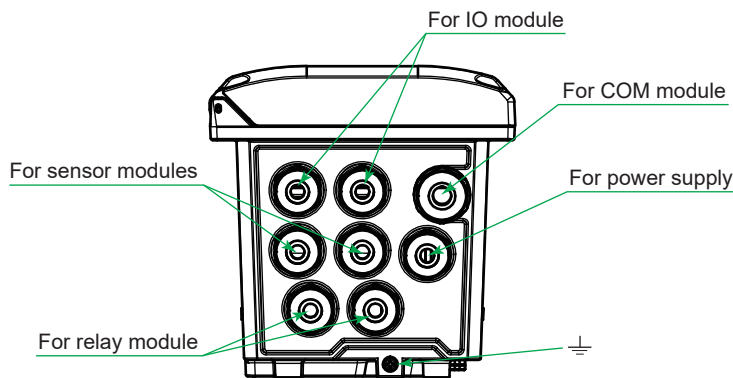

Figure 2.3 Cable gland configuration

### CAUTION

Be careful not to be injured by the sharp hole edges on the housing.

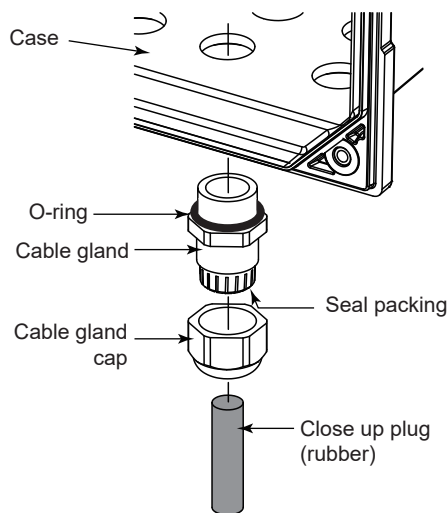

Figure 2.4 Cable glands

### CAUTION

To install cable glands, tighten it with torque of 2 N•m.

● **Conduit adapter**

When protecting the cable with a conduit, use an adapter. (option codes: /CB4, /CD4, /CF4, /CB6/ CD6 /, /CF6)

**CAUTION**

There are 8 holes for cable connection. Apply the cable gland of supplied accessories (dark-grayed cable glands) to the holes which no conduit adapters connect to.

Apply the supplied cable gland for adapter (white) to the holes which conduit adapters connect to instead of using supplied-accessory cable gland (dark gray). (Figure 2.5)

Caps of cable glands are not used.

For Ethernet wiring, use Cable gland for Ethernet (black) and Conduit adapter for Ethernet (punched with a letter “E”).

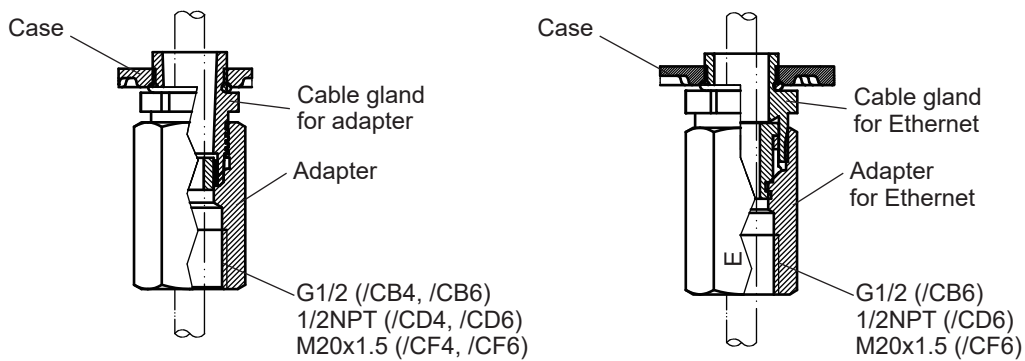

Figure 2.5 Conduit adapter (option)

**CAUTION**

When using a cable conduit, use a flexible conduit to avoid stress on the conduit adapter. The excessive stress on the conduit adapter may damage the housing.



## 2.5 Wiring

Wire in the following steps. (Figure 1.3) (Each parenthesis shows the section number to see.)

- 1: Power supply terminals (See 2.5.1 Wiring the power supply)
- 2: Relay module (2.5.2 Wiring relay module (Contact outputs))
- 3: Communication module (2.5.3 Wiring network cables)
- 4: 2nd sensor module (2.6 Sensor wiring)
- 5: 1st sensor module (2.6 Sensor wiring)
- 6: IO module (2.5.4 Wiring IO module)

1st and 2nd order shown above are reversible. When wiring be sure to remove the shield cover. After the wiring, screw up the shield cover.

### WARNING

Use wiring cables with heat resistance above 75 °C, waterproof rating IP66 or higher.

Four front panel screws should be tightened to the following torque; 1.5 to 1.6 N·m.

For power supply, wire cables with a flammability rating of UL 2556 VW-1 or equivalent.

### WARNING

Always place the shield cover over the power supply and contact terminals for interference avoidance and safety reasons.

### CAUTION

Turn off power supply to FLXA402 before wiring cables.

### CAUTION

After wiring of power supply or contact output is completed, put on the shield cover. (see section 2.3)

### NOTE

#### Grounding of shielded cable

The shielded cables are very effective for noise-rejection, but the grounding of the shielded cables varies depending on the conditions of use.

One side grounding, which grounds only one end of the shield to FLXA402, requires longer cables and is effective for noise reduction when there is a potential difference of grounds between the FLXA402 and the connected device on the other side.

If there is no potential difference between the FLXA402 and the device on the other side, it may be more effective to connect to the ground on both sides.

It may also be effective to connect a capacitor in series to one ground while both sides being grounded.

However, it is assumed that sensors are used with one side grounding. Therefore, be careful not to use those sensors with both sides grounded.

## 2.5.1 Wiring the power supply

### CAUTION

Turn off power supply to FLXA402 before wiring. Power rating must comply with FLXA402 specification. Power voltage must match with the one indicated on the name plate.



### WARNING

- You must install external power supply switch or circuit breaker for power supply.
- The external power supply switch or a circuit breaker must comply with a current rating of 5A or IEC60947-1 or IEC60947-3
- Yokogawa recommend installing the external power supply switch, circuit breaker and FLXA402 converter all in the same location.
- Install the external power supply switch or circuit breaker to the place where operators access easily. To alert users, put a label on the external power switch.
- Wire cables of power supply, contact output securely with cable rack, conduit and vinyl band. Unplugged cables are dangerous and may cause an electric shock.

To prepare for wiring cables, open the front panel and remove the shield cover so that you can access terminals easily.

The cable size of terminals is 2.5 mm<sup>2</sup> in cross-sectional area or AWG14. Use the solderless terminals.

**■ Wiring the power supply**

Select AC (-A) or DC (-D) power supply wiring.

**● AC power supply**

Match the terminal block code “L” “N” with those of the cables.

See Figure 2.8 on grounding. Use cables of rated voltage 300 V AC or greater.

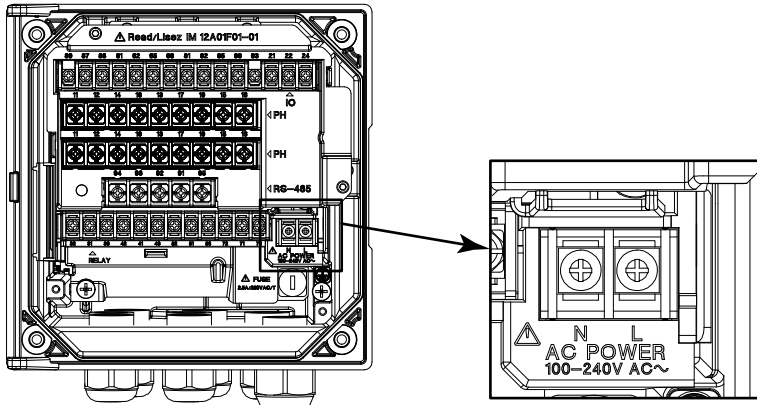

Figure 2.6 AC power supply

**● DC power supply**

Match the terminal block code “+” “-” with those of the cables.

Use Conductors with a cross sectional area of 1.25 mm<sup>2</sup> or greater,

Cables with an outer diameter of 6 to 12 mm,

Cables with rated voltage 30 V AC or greater.

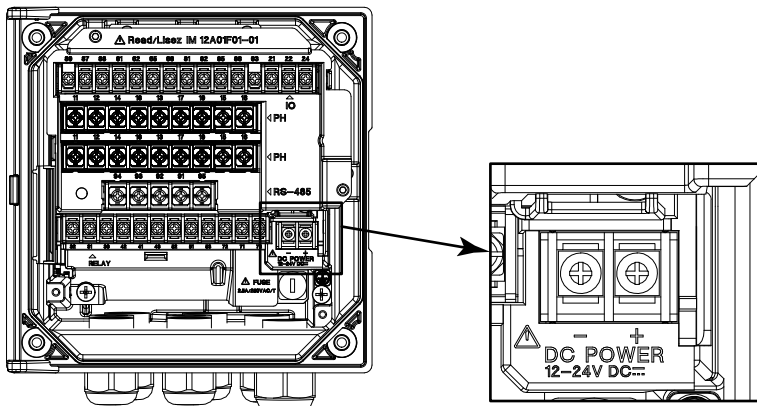

Figure 2.7 DC power supply

**■ Grounding**

**CAUTION**

Connect FLXA402 to ground. (Class D ground: 100 ohm or less) for interference avoidance and safety reasons.

Use ground cables with larger cross - sectional area. Fix the cable on the rear side of FLXA402 outer case or connect the grounding cable to the terminal of the power module inside. See Figure 2.8.

Use ring terminals for wiring terminals.

## WARNING

Use the protective earth conductors whose minimum size of the cross-sectional area is 0.75 mm<sup>2</sup>. For CSA compliance (Type: -AD), use ones with cross-section area of 0.75 mm<sup>2</sup> to 2.1 mm<sup>2</sup>.

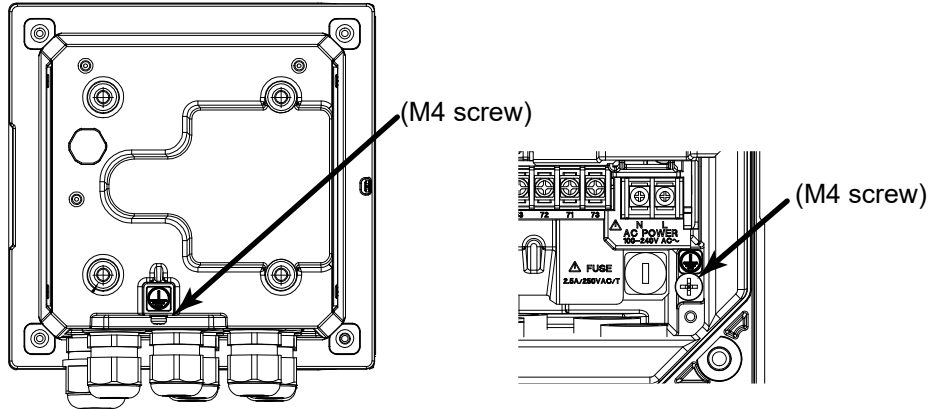

Figure 2.8 External grounding (rear side), internal grounding

## NOTE

- FLXA402 on AC power supply requires the protective grounding.
- The converter on DC power supply does not require the protective grounding but it does function grounding.
- It has the same type of case as the converter on AC power supply, therefore you see the symbol of protective grounding  $\oplus$ . Recognize the symbol as function ground terminal.
- When selecting Type “-DD” (Nonincendive for FM), please check the condition of Control Drawings.

## CAUTION

Put the shield cover back in place after the wiring of power supply terminal and contact output terminals, if the converter has a relay module, are completed.

## 2.5.2 Wiring relay module (Contact outputs)

Contact configuration of FLXA402 is the Single Pole Double Throw SPDT relay, which allows signals to be used as digital output to controller or PLC etc.

Use multi-core cables for contact output signals.

Those screws of contact terminals are all M3 with washer.

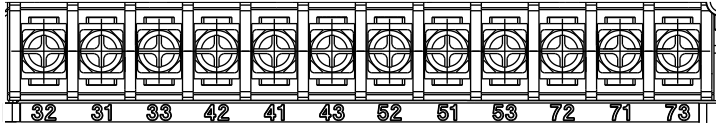

Terminal number	Contact terminals	Description
32	S1(NC)	Contact S1 Normally Close
31	S1(C)	Contact S1 Common
33	S1(NO)	Contact S1 Normally Open
42	S2(NC)	Contact S2 Normally Close
41	S2(C)	Contact S2 Common
43	S2(NO)	Contact S2 Normally Open
52	S3(NC)	Contact S3 Normally Close
51	S3(C)	Contact S3 Common
53	S3(NO)	Contact S3 Normally Open
72	S4(NO)	Contact S4 Normally Open
71	S4(C)	Contact S4 Common
73	S4(NC)	Contact S4 Normally Close

Figure 2.9 Relay module contacts

FLXA402 has 4 contact outputs, which allows configuration to adjust to operation. Contact S4 is fail safe contact. See IM-Converter operation IM 12A01F01-03EN Section 4.4.

There are 2 cable inlets. Take a suitable one to run wiring with good structure. Be sure to plug unused cable gland with a supplied rubber close up plug.

### NOTE

When selecting Type “-DD” (Nonincendive for FM), please check the condition of Control Drawings.

- **Alarm (Process Alarm monitoring)**

Contact outputs an alarm when a measurement exceeds or falls below the permissible range.

● **Error**

Contact outputs Error (“Fault” or “Warning”). Internal function of electric circuit alerts some errors automatically. You can define “Fault” or “Warning” for general errors. See IM-Converter operation IM 12A01F01-03EN\_Section 4.7

Contact for Error must connect to alarm related components including alarm lamp, alarm bell, indicators.

The table below shows the relay operation. Go to Main screen and tap  to display contact status. See IM 12A01F01-03EN\_2.2 Main screen.

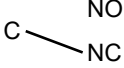
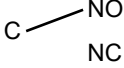
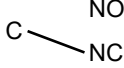
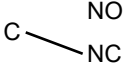
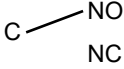
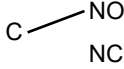
Contact terminals	Normal operation when power on	Alarm on when power on	Power off
S1, S2, S3			
S4			

### 2.5.3 Wiring network cables

FLXA402 provides two types of wired digital network, Ethernet (Modbus TCP/IP) or RS-485 (Modbus RTU).

Use shielded cable to avoid deteriorated performance caused by EMI disturbance or radiation effects on electric devices.

#### ■ RS-485 cabling

Suffix code -R is specified, i.e. (Modbus RTU (RS-485)) of digital communication.

All screws for the network module terminals are M3 with washers.

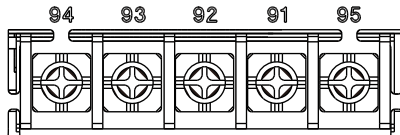

Terminal number	terminal name	Application
94	SHILD	Shield
93	GND	Signal ground
92	B-	data-negative
91	A+	data-positive
95	Term	terminal for termination resistor (110 Ω)

Figure 2.10 Network module terminal

Use multi-core shielded cable whose core wire is twisted pair. Connect them to terminal 94.

According to your network environment, terminate the network by using the built-in termination resistors with a value of 110 Ω.

Jumper terminals 91 and 95 with each other with a supplied jumper. (Figure 2.11) The jumper terminates signals inside the module. In this case, the screw of terminal 91 is tightened with the signal cable and the jumper all together.

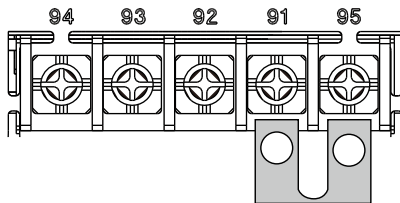

Figure 2.11 How to terminate RS-485 connection

#### NOTE

If you don't need the termination, keep the jumper in the jumper holder attached to the back of the front panel to avoid losing it. (Figure 1.6)

## ■ Ethernet cabling

Suffix code-E is specified. (Modbus TCP/IP) Figure 2.12 shows the positions of RJ45. Use STP shield cable of category 5 or greater to the RJ45 connector. You can apply both straight and crossover cable for Ethernet cabling.

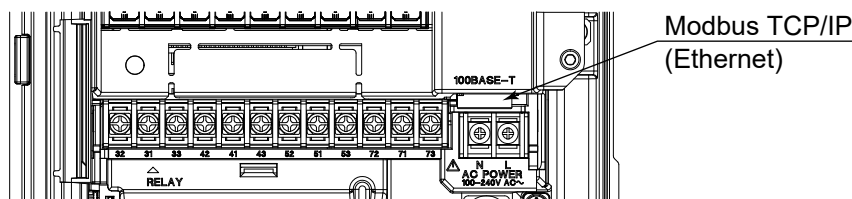

Figure 2.12 Network module (Ethernet) connector

### NOTE

Use cable gland or adapters (option) for Ethernet.

## 2.5.4 Wiring IO module

First complete the sensor wiring. (Read 2.6)

Wire for mA input, mA output, contact input. Wiring for mA input may not be necessary according to the specification.

### ■ Wiring mA output

FLXA402 transmits 4-20 mA analog signals with maximum load of 600 Ω to peripherals including a control system or recorders. IO module has mA output function.

Be sure to use shielded cables for output signal cables, and connect shield to terminal 63 (or 89\*).

\*: When mA I/O is “-A4”, the terminal 89 is used for mA input and cannot be used for output.

Use cables of rating 30 V AC or greater.

For wiring, use shielded multi-core cables.

Screws for IO module are all M3 with washers.

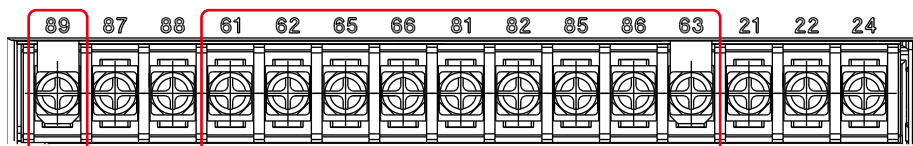

Terminal number	Contact terminals	Description
61	mA1+	4-20 mA output 1+(with HART)
62	mA1-	4-20 mA output 1-
65	mA2+	4-20 mA output 2+
66	mA2-	4-20 mA output 2-
81	mA3+	4-20 mA output 3+ *1
82	mA3-	4-20 mA output 3- *1
85	mA4+	4-20 mA output 4+ *1
86	mA4-	4-20 mA output 4- *1
63	SHILD	Shield
89	SHILD	Shield

\*1 only when mA output is -A4 in the Suffix Codes.

Figure 2.13 IO module terminal assignment



## ■ mA input

This describes a wiring when the suffix code for mA Output/Input is -A4.

FLXA 402 receives 4-20 mA analog signals inputs of pressure compensation for DO sensors, or of temperature compensation for pH, SC, ISC, DO sensors.

Use shielded cable for input signal cable and connect the shield to terminal 89. Rated voltage of cable is 30 V AC or greater. For wiring use multicore shielded cable. Screws for IO module terminals are all M3 with washers.

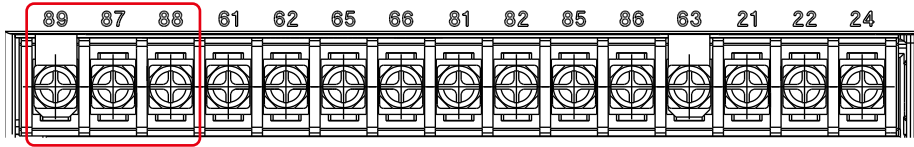

Terminal number	Contact terminals	Description
87	AI+	4-20 mA input +
88	AI--	4-20 mA input-
89	SHILD	Shield

Figure 2.14 IO module terminal assignment

## ■ Contact input

IO module contains contact input function which is for starting WASH CYCLE or changing RANGE of 4-20 mA output.

For input signal cable, use shielded cables. Connect the shield to terminal 63.

All screws are M3 with washers.

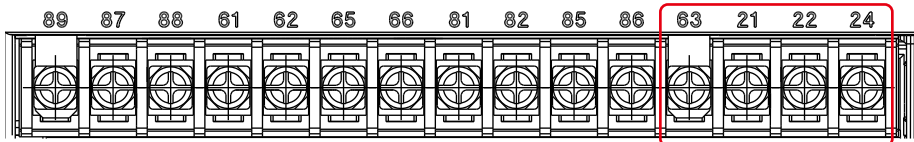

Terminal number	Contact terminals	Description
21	DI1	Contact input 1
22	COM	Contact input common
24	DI2	Contact input 2*1
63	SHILD	Shield

\*1 when mA IO code -A4 is selected

Figure 2.15 IO module terminal assignment

When all wiring is complete, close the FLXA402 front cover, and turn the power on.

Check that the screen displays normally.

## CAUTION

To install the front panel, tighten each screw evenly until every four of them is completely fastened. For example turn each screw in two times and repeat it until all of the screws are evenly tightened up

Do not use an electric screwdriver with high revolutions such as 1000 rpm. The revolutions of the electric screwdriver should be less than 400 rpm.

Four front panel screws should be tightened to the following torque; 1.5 to 1.6 N•m

## 2.6 Sensor wiring

The FLXA402 can be used with a wide range of commercially available sensor types, both from Yokogawa and other manufacturers.

Terminal screw size is M3, and torque of screw up is 0.6 N•m.

Pin terminal, ring terminal and spade terminal can be used.

Pin terminal: pin diameter: max. 1.9 mm

Ring and fork (spade) terminal: width: max. 7.8 mm

For details on the sensors, refer to the respective instruction manuals of the sensors.

### NOTE

When the second input is used, the upper-level module is for the first input. Be careful not to make a mistake when wiring the modules.

If the second input is available, wire the second module in the lower level first.

There are two cable entry holes. Both can be used.

When the second input is not available, be sure to plug holes of unused cable gland with the supplied rubber close up plug.

The table below shows the section of this IM describing the wiring of first/second input according to the suffix code.

Suffix code	Input	Section
-P1	pH/ORP PH)	2.6.1
-C1	Conductivity (SC)	2.6.2
-C5	Inductive conductivity (ISC)	2.6.3
-D1	Dissolved oxygen (DO)	2.6.4
-D5, -D6	Digital sensor	2.6.5
-S5	SENCOM SA	2.6.6

### CAUTION

It is assumed that sensors are used with one side grounding. Therefore, be careful not to use those sensors with both sides grounded.

■ Wiring of YOKOGAWA sensors

Sensor	Measurement	FLXA402 Terminals									Short *2 FLXA402 /FLXA21 Terminals	Remark	
		11	12	13	14	15	16	17	18/13	19/15			
		Sensor cable marking (or color)							Jumper *1				
DO30G	DO	11	12	13	14	15	16						Fixed Cable
FU20/ PH20/ FU24	pH, pH & ORP, rH	11	12	13	14	15	16		Yes	No			Fixed Cable
FU20/ PH20/ FU24	ORP	11	12	13		14			Yes	Yes	13/14		Fixed Cable
FU20/ PH20/ FU24	pH Comp. ORP	11	12	15		14		16	No	Yes	13/14		Fixed Cable
FU20-VP/ FU24-VP	pH, pH & ORP, rH	E	F	B	D	A			Yes	No			VP6-SC
FU20-VP/ FU24-VP	ORP	E	F	B		D			Yes	Yes	13/14		VP6-SC
FU20-VP/ FU24-VP	pH Comp. ORP	E	F	A		D			No	Yes	13/14		VP6-SC
ISC40	ISC	11	12	13	14	15	16						Fixed Cable
PR20/ PR10	pH	11	12	13	14	15	16		Yes	No			Fixed Cable
SC21	pH			Blue	Liquid Earth	Red		(White)	No	No			WU20 Triax
SC24V	pH	E	F	C	H	A	B	D					VP8-DC
SC25V	pH	E	F	B	D	A			Yes	No			VP6-SC
SC29-PTG	pH Comp. ORP			Red	Liquid Earth	Blue		(White)					WU20 Triax
SC29-PTP	ORP			Blue	Liquid Earth	Red		(White)	Yes	Yes			WU20 Triax
SC42	SC	11	12	13	14	15	16						WU40 cable
SC4A	SC	11	12	13	14	15	16						Fixed Cable
SM21/ SR20/ SM60	pH	Green: Red	Green: Blue	Yellow: Red	Black	Red: Red	Red: Blue	Yellow: Blue	Yes	No			WU20 Color Coded Coax
SM29/ SR20	ORP			Yellow: Red	Black	Red: Red	Red: Blue	Yellow: Blue	Yes	Yes			WU20 Color Coded Coax
SX42	SC	Brown	Brown	Yellow: Green		Red					13/14 and 15/16		Sensor Wiring

\*1: The jumper cables to short are attached to the product.

\*2: Jumper cables to short are supplied by users.

■ Wiring of HAMILTON sensors

Sensor	Measurement	FLXA402 Terminals										Short *2 FLXA402 /FLXA21 Terminals	Remark	
		11	12	13	14	15	16	17	18	18/13	19/15			
Sensor cable marking (or color)										Jumper *1				
CHEMTRODE	pH			Blue		Red		(White)			Yes	No	13/14	WU20D Cable
CHEMTRODE-ORP	ORP										Yes	Yes	13/14	
CHEMTRODE-VP	pH	E	F	B		A					Yes	No	13/14	VP6-SC
CLARITRODE	pH			Blue		Red		(White)			Yes	No	13/14	WU20D Cable
CLARITRODE-VP	pH	E	F	B		A					Yes	No		VP6-SC
CONDCUELL	SC	White/ Grey	Blue	Green	Pink	Brown	Yellow							Fixed Cable
CONDCUELL-VP	SC	Blue	Yellow	Black	Black Shield	Grey	Grey Shield							Hamilton VP Cable
EASYFERM	pH			Blue		Red		(White)			Yes	No	13/14	WU20D Cable
EASYFERM-VP	pH	E	F	B		A					Yes	No	13/14	VP6-SC
INCHTRODE	pH	E	F	B	D	A					Yes	No		VP6-SC
MECOTRODE	pH			Blue		Red		(White)			Yes	No	13/14	WU20D Cable
MECOTRODE-VP	pH	E	F	B		A					Yes	No		VP8-DC
OXYFERM-VP/ OXYGOLD	DO	White	Green		Green/ Yellow			Black	Red					Hamilton VP Cable
OXYSENS	DO	Yellow	Blue		Black			Clear	Brown					Fixed Cable
pHEASY	pH	E	F	B	D	A	B				Yes	No		
POLILYTE	pH			Blue		Red		(White)			Yes	No		WU20D Cable
POLILYTE-VP	pH	White	Green	Red	Blue	Black/ Clear					Yes	No		Hamilton VP Cable
POLILYTE PLUS-VP	pH	White	Green	Red	Blue	Black/ Clear					Yes	No		Hamilton VP Cable

\*1: The jumper cables to short are attached to the product.

\*2: Jumper cables to short are supplied by users.

Color coding of Variopin cables

Cable	PIN	A	B	C	D	E	F	G	H
Hamilton	VP6-SC	Black/ Clear	Red	Grey	Blue	White	Green		
Hamilton	VP8-DC	Black/ Clear	Black Shield	Red/ Clear	Red Shield	White	Green	Yellow	Brown
WU20-V-S	VP6-SC	Clear	Brown	Black	Yellow	Red	Blue		
WU20-V-D	VP8-DC	Brown Core	Brown Shield	White Cored	White Shield	Red	Blue	Yellow	

## 2.6.1 Wiring the pH/ORP sensor

### ■ pH Measurement

Conventional pH sensors are connected to the module as follows:

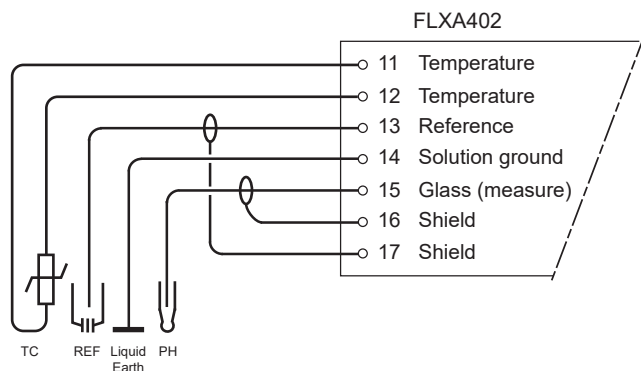
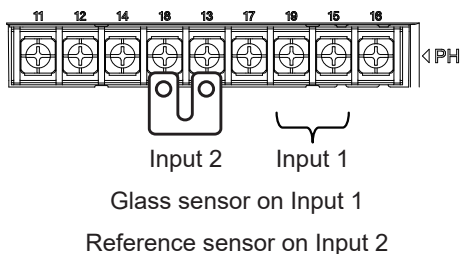

Figure 2.16

In addition to the wiring of the sensor, insure that a jumper for low-impedance sensor inputs is installed. Two jumpers are supplied with each module. Keep unused jumpers in the jumper holder to avoid losing them.

- pH Glass Electrode is a high impedance sensor input
- Standard reference electrodes and an ORP/REDOX electrode are low impedance sensor inputs
- Special electrodes using 2 glass sensors (example: Pfaudler, SC24V) do not need jumpers.

Terminals 15-19 are identified as input 1 (High Impedance) and terminals 13-18 are defined as input 2 (Low Impedance). For conventional pH sensors, the jumper is placed as illustrated:



Store jumpers that you do not use in the jumper holder.

### ■ ORP Measurement

The ORP measurement uses the same sensor input module as the pH measurement. It is not uncommon to measure ORP as process variable and a pH Glass electrode as reference. This is the case with rH measurement and with pH compensated ORP measurement.

Conventional ORP sensors are connected to the module as follows:

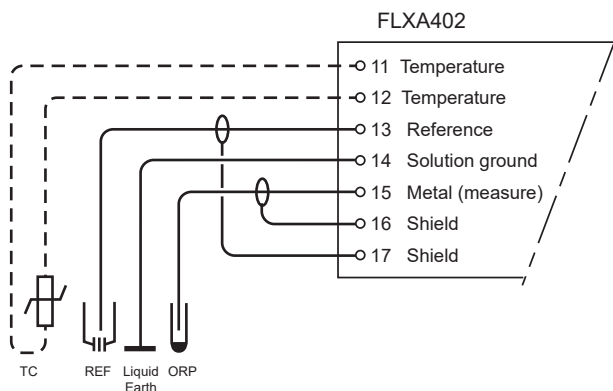

Figure 2.17

For conventional ORP sensors, the jumpers are placed as illustrated:

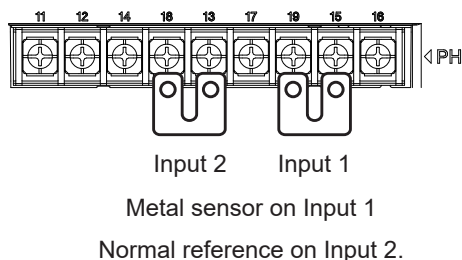

Figure 2.18

pH Compensated ORP sensors are connected to the module as follows:

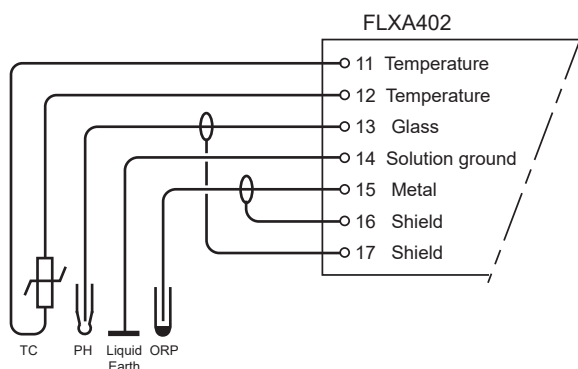

Figure 2.19

For pH Compensated ORP sensors, the jumper is placed as illustrated:

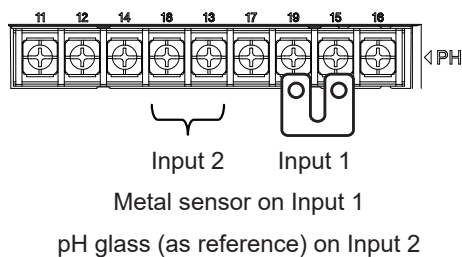

Figure 2.20

**NOTE**

The special grommet is intended to be used to seal the multiple cables from the Yokogawa flow fittings such as FF20.

The designated cables are WU20 sensor cables, which are approximately 5 mm (0.2”) in diameter, and K1500FV liquid earth cables, which are approximately 2.5 mm (0.1”) in diameter.

For sensor systems using a single cable, like the FU20/FU24 and the PR10, PD20, PF20 and PS20, the standard gland will accommodate the cable adequately. Single cables between approximately 6 mm and 12 mm (0.24" and 0.47") can be sealed properly with these glands and the standard tulle.

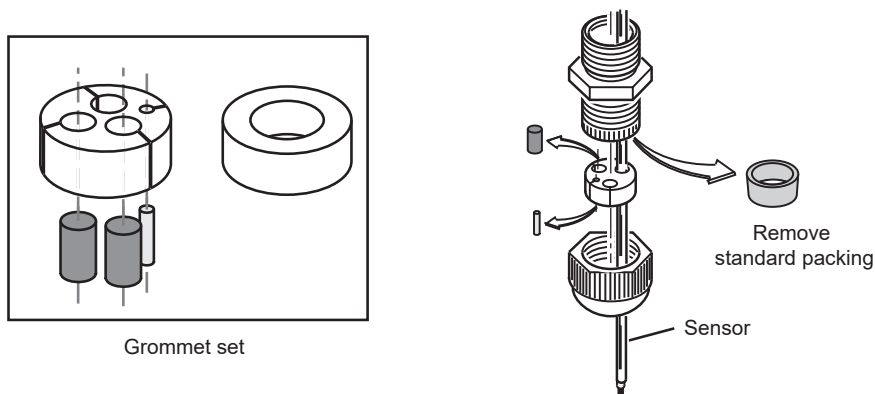

Figure 2.21 Grommet set use

### 2.6.2 Wiring the conductivity (SC) sensor

Contacting Conductivity, SC, sensors are connected to the module as follows:

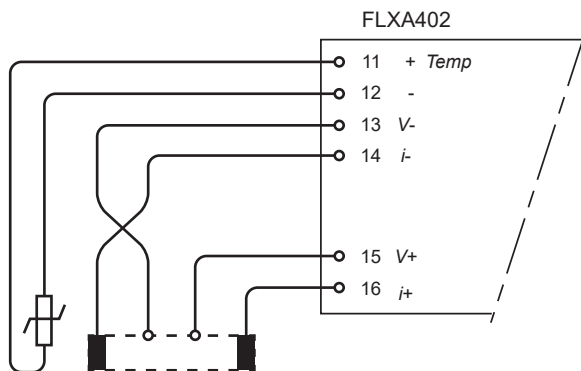

Figure 2.22

The above diagram shows wiring for 4-electrode conductivity sensors, such as SC42-SP34 large bore series. For 2-electrode conductivity sensors, such as SC42-SP36 small bore series, jumpers must be installed between terminals 13-14 and between terminals 15-16, as shown in the diagram below.

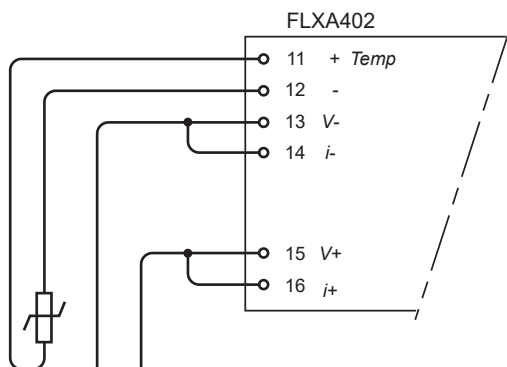

Figure 2.23

### 2.6.3 Wiring the inductive conductivity (ISC) sensor

ISC40 sensors are connected to the module as follows:

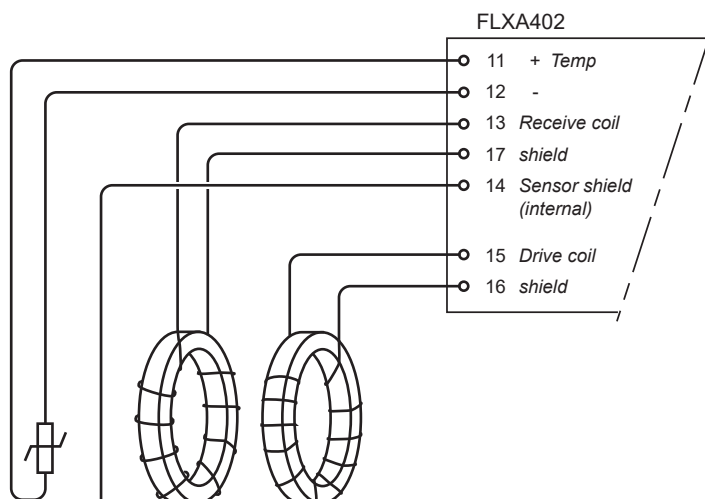

Figure 2.24

The sensors are supplied with integral cables and each individual wire is marked with the corresponding terminal numbers.

### 2.6.4 Wiring the dissolved oxygen (DO) sensor

The input module for DO measurement is suitable for different types of DO sensors:

- i. Galvanic sensors like model DO30G
- ii. Polarographic sensors like HAMILTON'S Oxyferm and Oxygold

The connection is as follows:

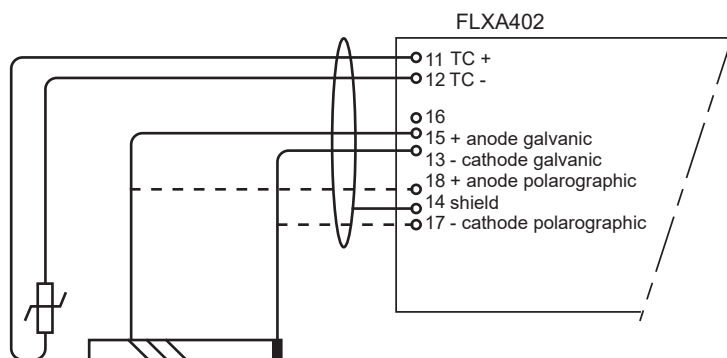

Figure 2.25

The DO30G sensor comes with integral cable and the wires are labeled with the corresponding terminal numbers.

#### NOTE

When Type is “-DD” (Nonincendive for FM), -D1 (DO) cannot be selected.



## 2.6.5 Wiring digital sensors

When suffix code -D5 or -D6 (digital sensors) for 1st input is specified.

Be sure to find the label “DIGITAL SENSOR” beside the terminals.

Screws are all M3 with washers.

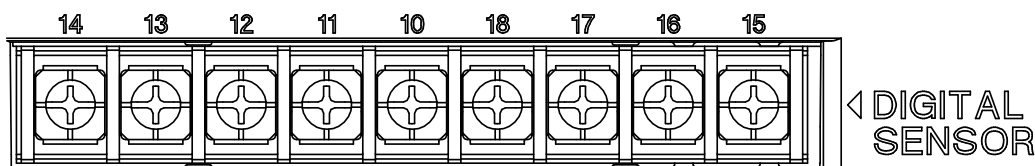

Figure 2.26 Digital sensor module terminal assignment

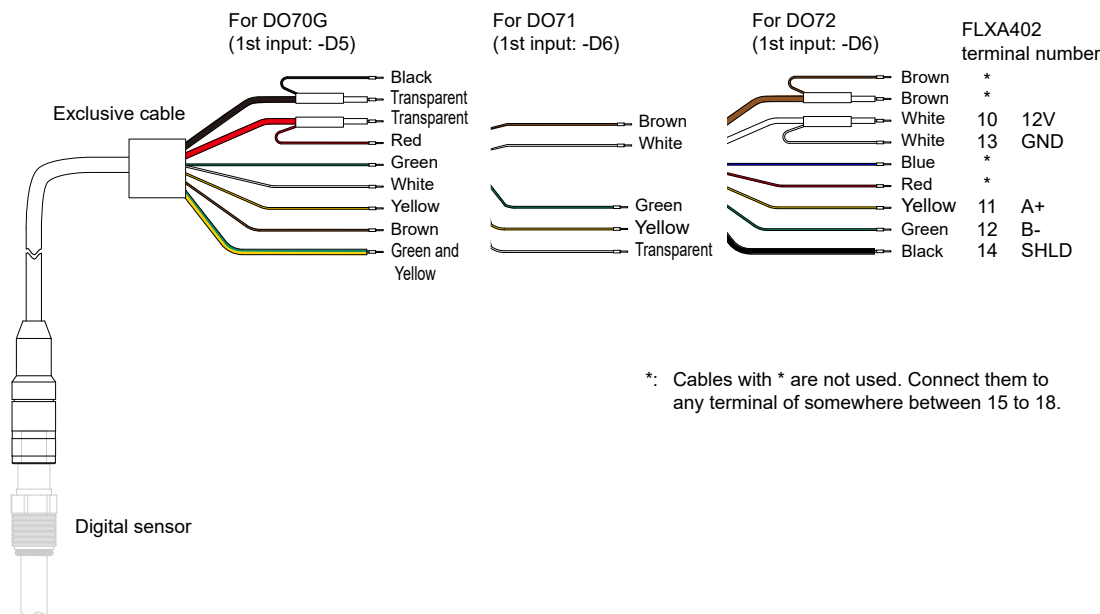

Figure 2.27 Wiring digital sensors

For each Digital sensor, see the dedicated Instruction Manual for it.

FLXA402 detects the sensor connected and displays an alarm if the sensors are not connected.

### Note

When “-D6” is specified for the 1st input and if the sensor except the product made in YOKOGAWA is used, SENCOM comm. error occurs and the sensor is not detected.

Because DO71 cables are thin, first remove the cable gland’s standard packing and apply the supplied grommet instead. (For DO70G and DO72, do not use grommet, use standard packing.)

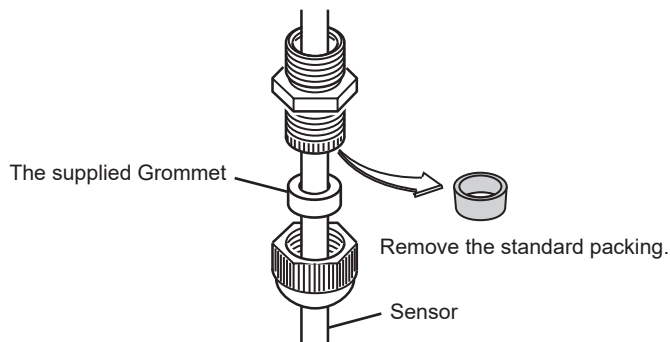

Figure 2.28

---

**CAUTION**

Turn off the power to FLXA402 when pulling off cables from the digital sensors, or connecting the digital sensors to cables which are already wired to FLXA402.

---

**NOTE**

When Type is “-DD” (Nonincendive for FM), -D5 and -D6 (Digital Sensor) cannot be selected.

---

## 2.6.6 Wiring sensors with SENCOM SA

When suffix code -S5 (SENCOM SA) for 1st or 2nd input is specified.

The next figure shows a wiring with WU11, which connects to SENCOM SA.

Be sure to find the label “SENCOM SA” beside the terminals. Screws are all M3 with washers.

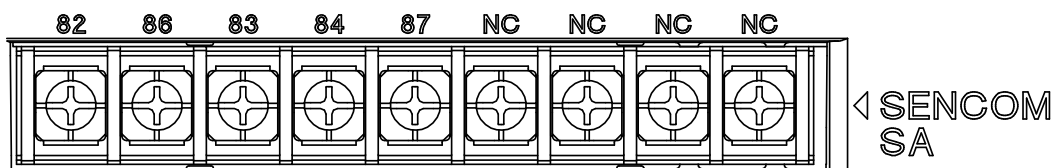

Figure 2.29 SENCOM module terminal assignment

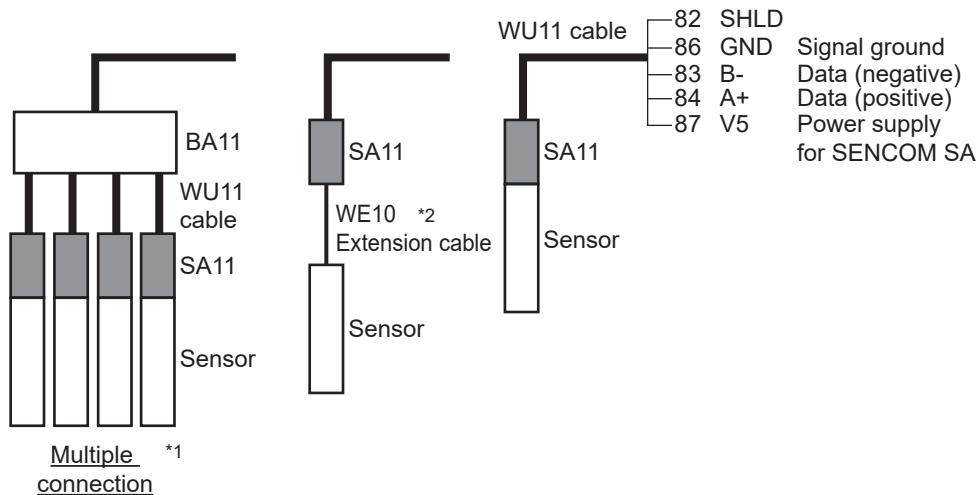

Figure 2.30 Wiring SENCOM SA

- \*1: Multi sensor connection: 1st sensor module can connect up to 4 sensors equipped with SA11 SENCOM SA, via BA11 junction box.  
Note: When selecting Type “-DD” (NI for FM), Multi sensor connection cannot be used. Only one sensor can connect.
- \*2: WE10 is an extension cable stretching between SA11 and sensors. WE10 is universal to connections if needed.

Connect a SA11 SENCOM Smart adapter to a sensor. Connect SA11 to FLXA 402 via WU11 SENCOM cable.

Read each exclusive user’s manual for information on SA11 Smart Adapter, WU11 Interconnection/Extension Cable for SENCOM Products, WE10 extension cable, BA11 Active Junction Box.

Because WU11 cables are thin, first remove the cable gland’s standard packing and apply the supplied grommet instead.

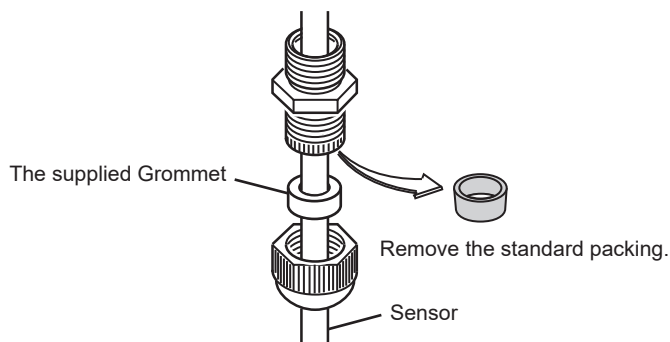
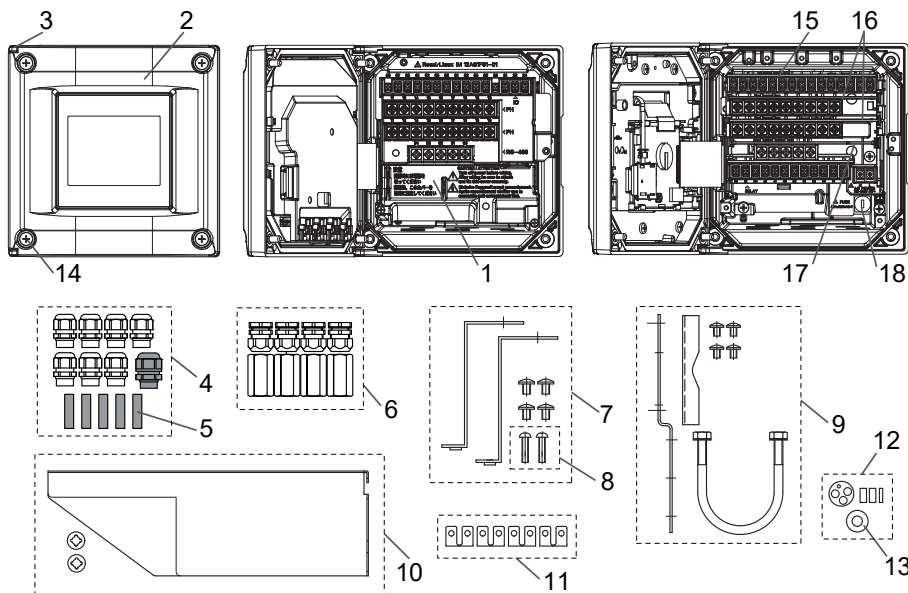

Figure 2.31

FLXA402 acknowledges the connection of sensors, if not, FLXA402 alerts an error.

# Customer Maintenance Parts List

## FLXA402 4-Wire Converter



Item	Part No.	Qty	Description	Item	Part No.	Qty	Description
1	K9703SA	1	Shield plate assembly	11	K9703ZM	2	Jumper set (for pH, RS485), 5 pcs
2	—	—	Cover assembly	12	K9676BY	1	Grommet set (only for pH)
	K9703QK	1	Urethane coating	13	K9676CL	1	Grommet (only for SENCOM SA)
	K9703QM	1	High anti-corrosion coating	14	K9699PL	5	Screw assembly (M5 screw + spring)
3	K9699PP	1	Hinge pin assembly (Hinge pin + spring)	15	—	—	IO module assembly, QIC sheet is included.
4	—	—	Cable gland set		K9704QB	1	mA Output/Input: -A2 (FLXA402-D)
	K9703PC	1	Cable gland x8 + Rubber plug x5		K9704QD	1	mA Output/Input: -A2 (FLXA402-A *1)
	K9703PE	1	Cable gland x7 + for Ethernet x1 + Rubber plug x5		K9704QC	1	mA Output/Input: -A4 (FLXA402-D)
5	K9334CN	1	Rubber plug (for auxiliary component)		K9704QE	1	mA Output/Input: -A4 (FLXA402-A *2)
6	—	—	Adapter set for conduit work (Conduit adapter + Cable gland)	16	—	—	Sensor module assembly, QIC sheet is included.
	K9703WF	1	G1/2 x 4 sets	(See Table 1)		1	1st/2nd input: -P1 (pH/ORP (PH))
	K9703WG	1	1/2NPT x 4 sets	(See Table 1)		1	1st/2nd input: C1 (Conductivity (SC))
	K9703WH	1	M20x1.5 x 4 sets	(See Table 1)		1	1st/2nd input: -C5 (Inductive conductivity (ISC))
	K9703WJ	1	G1/2 x 3 sets + for Ethernet x1 set	(See Table 1)		1	1st/2nd input: -D1 (Dissolved oxygen (DO))
	K9703WK	1	1/2NPT x 3 sets + for Ethernet x1 set	(See Table 1)		1	1st input: -D5, -D6 (Digital sensor)
	K9703WL	1	M20x1.5 x 3 sets + for Ethernet x1 set	(See Table 1)		1	1st/2nd input: -S5 (SENCOM SA)
7	K9703ZD	1	Panel mounting set (option code: /PM)	17	—	—	Communication module assembly, QIC sheet is included.
8	K9703ZL	2	Screw set (for panel mount), 2 pcs		K9704PB	1	Digital Communication: -E (Modbus TCP/IP)
9	K9703SS	1	Pipe and wall mounting set (option code: /U)		K9704PC	1	Digital Communication: -R (Modbus RTU (RS-485))
10	—	—	Sun shade hood set				
	K9698WK	1	Stainless steel (option code: /H6)				
	K9698WL	1	Stainless steel with urethane coating (option code: /H7)	18	A1633EF	1	Fuse

\*1: If the suffix code includes /K or the STYLE displayed on the nameplate is S1.09 or earlier, K9704QB applies.

\*2: If the suffix code includes /K or the STYLE displayed on the nameplate is S1.09 or earlier, K9704QC applies.

**Table 1 Item 1; Sensor module assembly, QIC sheet is included.**

Type code Module	-AB, -AD, -AG, -AJ, -AQ, -AR (General purpose)	-DD (NI for FM) *1
pH/ORP	K9704EB	
SC	K9704FB	
ISC	K9704GB	
DO	K9704HB	—
Digital sensor	K9704SC	—
SENCOM SA *2	K9704SB	K9704SA

\*1: If you like to replace sensor modules within explosion proof model (Type -DD (NI for FM)) for maintenance, please consult us.

\*2: Module for general purpose can not be used for Type -DD (NI for FM).

Note: The part numbers in Table 1 are modules with QIC. Sensor module number in the Table 2 shows each model number printed on the QIC. However, you can not order with the sensor module number in Table 2.

**Table 2 Sensor module number (reference)**

Sensor module assembly	Sensor module number	Sensor module assembly	Sensor module number
<b>K9704EB</b>	K9704ED	<b>K9704SC</b>	K9704SG
<b>K9704FB</b>	K9704FD	<b>K9704SB</b>	K9704SF
<b>K9704GB</b>	K9704GD	<b>K9704SA</b>	K9704SE
<b>K9704HB</b>	K9704HD		

---

# Revision Record

- Manual Title : Model FLXA402 4-Wire Converter Installation and Wiring  
(Introduction and General Description)

- Manual No. : IM 12A01F01-02EN

**Feb. 2024/11th Edition**

Revised CMPL 12A01F01-01EN.

**Nov. 2023/10th Edition**

Revised CMPL 12A01F01-01EN.

**Apr. 2023/9th Edition**

Revised CMPL 12A01F01-01EN.

**Nov. 2022/8th Edition**

Added -D6 (pages 1-3, 1-7, 1-9, 2-15, 2-22 to 2-24)

Revised CMPL 12A01F01-01EN.

**Nov. 2020/7th Edition**

Corrections (page 2-9)

Revised CMPL 12A01F01-01EN.

**Sep. 2020/6th Edition**

Added notes (pages 1-9, 2-24)

Revised CMPL 12A01F01-01EN.

**July 2019/5th Edition**

Revised CMPL 12A01F01-01EN.

**July 2019/4th Edition**

Added SENCOM SA for SC (pages ii, 1-1)

Other modification (page 2-6)

Corrections (page 2-16)

**Apr. 2019/3rd Edition**

Added Control Drawings (pages v, vi)

Modified (pages. 1-1, 1-2, 1-9, 2-9, 2-10, 2-22, 2-23, 2-24)

Customer Maintenance Parts List was newly released.(CMPL 12A01F01-01EN)

**Feb. 2019/2nd Edition**

Modified Model & Suffix Codes. (pages. 1-7, 1-9)

**Nov. 2018/1st Edition**

Newly published

---

Yokogawa Electric Corporation  
2-9-32 Nakacho, Musashino-shi, Tokyo 180-8750, JAPAN  
<http://www.yokogawa.com/>

---



