



◆ Introduction

Thank you for purchasing the SC92 Portable Conductivity Meter.

This Instructor's Manual contains all essential information for the user to make full use of the SC92.

Please read the following respective documents before using the SC92.

The related documents are listed as follows.

User's Manual

Contents	Document number	Note
SC92 Portable Conductivity Meter Start-up and Safety Precautions	IM 12D03E02-01EN	Printed manual
SC92 Portable Conductivity Meter User's manual	IM 12D03E02-02EN	Online manual (This manual)

"EN" in the document number is the language code.

An exclusive User's Manual might be attached to the products whose suffix codes or option codes contain the code "Z" (made to customers' specifications). Please read it along with this manual.

You can download the latest documents from our website.

<https://www.yokogawa.com/an/sc92/>



■ Product safety tips



WARNING

- Do NOT use this instrument where there is a possibility of electrical shock.
 - Do NOT touch any part of the electrode immediately after using in very hot liquids. Otherwise, you may get burned.
 - The product contains devices that can be damaged by electrostatic discharge. When inserting batteries and connecting a sensor, take care to prevent such a damage.
-
- The Instrument is packed carefully with shock absorbing materials, nevertheless, the instrument may be damaged or broken if subjected to strong shock, such as if the instrument is dropped. Handle with care.
 - Do not use abrasives or organic solvents.



CAUTION

- Do not apply physical shock or excessive force to the glass sensor, or it may break.
 - If the meter will not be used for an extended period of time, be sure to remove the batteries. Otherwise battery leakage may occur, causing damage to or malfunction of the meter.
 - Use both meters and sensors made by YOKOGAWA. Otherwise, it will result not only voiding of our warranty, but also may impair the safety and performance of the instrument.
-

■ Notes on Handling User's Manuals

- Please hand over the user's manuals to your end users so that they can keep the user's manuals on hand for convenient reference.
- Please read the information thoroughly before using the product.
- The purpose of these user's manuals is not to warrant that the product is well suited to any particular purpose but rather to describe the functional details of the product.
- No part of the user's manuals may be transferred or reproduced without prior written consent from YOKOGAWA.
- YOKOGAWA reserves the right to make improvements in the user's manuals and product at any time, without notice or obligation.
- If you have any questions, or you find mistakes or omissions in the user's manuals, please contact our sales representative or your local distributor.

■ Drawing Conventions

Some drawings may be partially emphasized, simplified, or omitted, for the convenience of description.

Some screen images depicted in the user's manual may have different display positions or character types (e.g., the upper / lower case). Also note that some of the images contained in this user's manual are display examples.

Flashing indication is represented by a pale color.

■ Trademark Notices

All other company and product names mentioned in this user's manual are trademarks or registered trademarks of their respective companies.

We do not use TM or ® mark to indicate those trademarks or registered trademarks in this user's manual.

■ Product disposal

Disposal of the product must be carried out in accordance with local and national laws/regulations.

■ Battery disposal

Batteries must be disposed of in accordance with local and national laws/regulations.

■ Warranty and service

YOKOGAWA products and parts are guaranteed free from defects in workmanship and material under normal use and service for a period of (typically) 12 months from the date of shipment from the manufacturer.

Individual sales organizations can deviate from the typical warranty period, and the conditions of sale relating to the original purchase order should be consulted. Damage caused by wear and tear, inadequate maintenance, corrosion, or by the effects of chemical processes are excluded from this warranty coverage.

For warranty claims for replacement or repair (at our discretion), please contact our sales representative. We will replace or repair at our discretion. The following information must be included in the letter accompanying the returned goods:

- Part number, model code and serial number
- Original purchase order and date
- Length of time in service and a description of the process
- Description of the fault, and the circumstances of failure
- Process/environmental conditions that may be related to the failure of the device.
- Warranty coverage statement: In-warranty or out-of-warranty repairs

Returned goods that have been in contact with process fluids must be decontaminated/disinfected before shipment. Goods should carry a certificate to this effect, for the health and safety of our employees.

Material safety data sheets should also be included for all components of the processes to which the equipment has been exposed.

◆ Safety Precautions

■ Safety, Protection, and Modification of the Product

- In order to protect the system controlled by the product and the product itself and ensure safe operation, observe the safety precautions described in this user's manual. We assume no liability for safety if users fail to observe these instructions when operating the product.
- If this instrument is used in a manner not specified in this user's manual, the protection provided by this instrument may be impaired.
- If any protection or safety circuit is required for the system controlled by the product or for the product itself, prepare it separately.
- Be sure to use the spare parts approved by Yokogawa Electric Corporation (hereafter simply referred to as YOKOGAWA) when replacing parts or consumables.
- Modification of the product is strictly prohibited.
- The following safety symbols are used on the product as well as in this manual.



WARNING

This symbol indicates that an operator must follow the instructions laid out in this manual in order to avoid the risks, for the human body, of injury, electric shock, or fatalities. The manual describes what special care the operator must take to avoid such risks.



CAUTION

This symbol indicates that the operator must refer to the instructions in this manual in order to prevent the instrument (hardware) or software from being damaged, or a system failure from occurring.

CAUTION

This symbol gives information essential for understanding the operations and functions.

NOTE

This symbol indicates information that complements the present topic.

■ Warning and Disclaimer

The product is provided on an “as is” basis. YOKOGAWA shall have neither liability nor responsibility to any person or entity with respect to any direct or indirect loss or damage arising from using the product or any defect of the product that YOKOGAWA can not predict in advance.



Compliant Standards

EMC:

CE: EN 61326-1 Class B Table 1 (For use in a basic electromagnetic environment)

EN IEC 61326-1 Class B Table 1 (For use in a basic electromagnetic environment)

Influence of immunity environment (Criteria A): change of reading value is specified within ± 10 uS/cm

RCM: EN 61326-1 Class B, Table 1

KC: KS C 9610-6-2, KS C 9811

Environmental regulation:

RoHS Directive: EN IEC 63000

WEEE Directive: DIRECTIVE 2012/19/EU

REACH : Regulation(EC) 1907/2006

◆ CE marking products

■ Authorized Representative in EEA

The Authorized Representative for this product in EEA is Yokogawa Europe B.V. (Euroweg 2, 3825 HD Amersfoort, The Netherlands).

■ Identification Tag

This manual and the identification tag attached on packing box are essential parts of the product. Keep them together in a safe place for future reference.

■ Users

This product is designed to be used by a person with specialized knowledge.

■ Batteries

Prepare 2 batteries that type is AA (LR6) 1.5V by yourself since batteries are not included in this product. If required, please select batteries with the authorized certification mark for each country.

The batteries should be disposed of in accordance with local and national legislation/regulations.

■ How to dispose the batteries (This directive is valid only in the EU.)

This product complies with the WEEE Directive marking requirement.



This marking indicates that you must not discard this electrical/electronic product in domestic household waste.

Product Category

With reference to the equipment types in the WEEE directive Annex I, this product is classified as a “Monitoring and Control instruments” product.

Do not dispose in domestic household waste. When disposing products in the EU, contact your local Yokogawa office.

◆ Control of Pollution Caused by the Product

This is an explanation for the product based on “Control of Pollution caused by Electronic Information Products” in the People’s Republic of China.

产品中有害物质的名称及含量

部件名称	有害物质					
	铅 (Pb)	汞 (Hg)	镉 (Cd)	六价铬 (Cr (VI))	多溴联苯 (PBB)	多溴二苯醚 (PBDE)
本体	×	○	○	○	○	○
传感器 (PH92SN,OR92SN,SC92SN)	×	×	×	×	○	○
电缆	×	○	○	○	○	○

○：表示该有害物质在该部件中所有均质材料中的含有量都在GB/T26572所规定的限量要求以下。

×：表示该有害物质至少在该部件的某一均质材料中的含有量超出GB/T26572所规定的限量要求。

环保使用期限：这个标志是基于SJ/T11364，在中国（不包括台湾，香港，澳门）贩售的电子电器产品所适用的环保使用期限。



只要遵守产品上关于安全及使用上的注意事项，从制造之日起计算在该年限内，不会发生制品内的有害物质外泄，突然变异，对环境或人体以及财产产生重大影响的情况。

（注）该年限是《环境保护使用期限》，不是产品的保质期限。

另外，关于替换部件的推荐替换周期，请阅读使用说明书。

◆ KC marking Product

- (1) Trade Name : Yokogawa Electric Corp.
- (2) Model Name : See table below.
- (3) Date of Manufacturer : See name plate of product.
- (4) Manufacturer : Yokogawa Electric Corp.
- (5) Country of origin : Singapore

Model	Model Name	Registration Website URL
SC92	Portable Conductivity Meter	http://www.rra.go.kr/selform/YHQ-EEN529-3

SC92 Portable Conductivity Meter

IM 12D03E02-02EN 2nd Edition

CONTENTS

◆	Introduction.....	i
◆	Safety Precautions	iv
◆	Compliant Standards	v
◆	CE marking products	vi
◆	Control of Pollution Caused by the Product.....	vii
◆	KC marking Product.....	vii
1.	General Description	1-1
	1.1 Specifications.....	1-2
	1.2 Instrument Check.....	1-3
	1.3 Model and Suffix Codes	1-4
	1.4 Part Name and Functions	1-4
	1.5 Optional Accessories	1-8
	1.6 Dimensions.....	1-8
2.	Basic Operations	2-1
	2.1 Inserting the Batteries	2-1
	2.2 Connecting Sensor	2-2
	2.3 Changing Operation Mode.....	2-3
	2.4 Saving Data.....	2-4
3.	Measurement Mode (MEAS).....	3-1
4.	Setup Mode (SET).....	4-1
	4.1 Conductivity Setup (COND).....	4-1
	4.1.1 Cell constant (CELL).....	4-2
	4.1.2 Unit (UNIT).....	4-3
	4.1.3 Auto calibration (A.CAL)	4-3
	4.1.4 Temperature compensation factor (T.CFF).....	4-4
	4.1.5 Reference temperature (T.rEF).....	4-6
	4.1.6 Calibration data clear (C.CLR)	4-7
	4.2 Data Setup (DATA)	4-8
	4.2.1 Data log interval setup (LOG)	4-8
	4.2.2 All data clear (D.CLR).....	4-9
	4.3 General setup (GEN).....	4-9
	4.3.1 Stability check (STBL).....	4-10
	4.3.2 Auto power-off time setup (A.Off)	4-11
	4.3.3 Reset the meter (r.SET)	4-12

5.	Calibration Mode (CAL)	5-1
5.1	Standard Solution Calibration	5-1
5.2	Temperature Calibration	5-4
6.	Data Mode (DATA)	6-1
7.	Storage and Maintenance	7-1
7.1	Storage	7-1
7.2	Meter Maintenance.....	7-2
7.3	Sensor Maintenance	7-3
8.	Trouble Shooting	8-1
	Revision Record	i

1. General Description

The SC92 Portable Conductivity Meter is easy to carry, high-precision conductivity meter.

Equipped with electrode degradation diagnostic functions, the meters enable easily accurate measurement, and a data storage function allows for confirmation of past measurement data at any time.

In addition, water-resistant construction makes it safe to use even if it is accidentally dropped into water (press water, etc.), as well as for measurement in places where water drops may fall on it, like in the rain.

However, the main body is not completely sealed, so do not leave it in water for a long period of time or do not pour chemicals or other solutions on it.

● Key Features

- Clear large LCD display with back light
- Tough, handy portable meter, unbreakable plastic sensor
- Built-in sensor holder on the side
- Foldable back stand
- Visualized electrode diagnostic result for sensor degradation level
- 500 data memory
- Automatic Temperature Compensation (ATC), Manual Temperature Calibration (MTC)
- Auto-hold / Auto stable / Real-time measurement modes with stability indicators
- Auto power off function (time configurable: OFF, 1 to 30 minutes)
- 2 x AA batteries
- IP67 water ingress, dust-proof meter housing

1.1 Specifications

Measurement:	Conductivity or resistivity in aqueous solution								
Measuring range:	Conductivity (minimum to maximum range) with sensor for; <table border="0" style="margin-left: 20px;"> <tr> <td>high purity water:</td> <td>0-2.00 $\mu\text{S/cm}$ to 0-200.0 $\mu\text{S/cm}$</td> </tr> <tr> <td>general purpose:</td> <td>0-20.00 $\mu\text{S/cm}$ to 0-200.0 mS/cm</td> </tr> <tr> <td>chemical resistance:</td> <td>0-20.00 $\mu\text{S/cm}$ to 0-200.0 mS/cm</td> </tr> <tr> <td>high conductivity:</td> <td>0-200.0 $\mu\text{S/cm}$ to 0-2.000 S/cm</td> </tr> </table>	high purity water:	0-2.00 $\mu\text{S/cm}$ to 0-200.0 $\mu\text{S/cm}$	general purpose:	0-20.00 $\mu\text{S/cm}$ to 0-200.0 mS/cm	chemical resistance:	0-20.00 $\mu\text{S/cm}$ to 0-200.0 mS/cm	high conductivity:	0-200.0 $\mu\text{S/cm}$ to 0-2.000 S/cm
high purity water:	0-2.00 $\mu\text{S/cm}$ to 0-200.0 $\mu\text{S/cm}$								
general purpose:	0-20.00 $\mu\text{S/cm}$ to 0-200.0 mS/cm								
chemical resistance:	0-20.00 $\mu\text{S/cm}$ to 0-200.0 mS/cm								
high conductivity:	0-200.0 $\mu\text{S/cm}$ to 0-2.000 S/cm								
	Resistivity; 0.001 $\text{M}\Omega\cdot\text{cm}$ to 40.0 $\text{M}\Omega\cdot\text{cm}$ (with a sensor for high purity water measurement)								
	Temperature; 0 to 80°C (with sensors) *0 to 50°C when the sensor cable is immersed in process solution								
Number of display digits:	Conductivity: 4 digit maximum (automatic range switching) Resistivity: 4 digit maximum								
Temperature indication range:	-10.0 to 120.0°C								
Repeatability (Combined with sensors):	Conductivity: $\pm 2\%$ of full scale ($\pm 5\%$ of full scale of the 0-200 mS/cm range for general purpose type sensor)								
Temperature accuracy:	Simulated input for main unit only; $\pm 0.5^\circ\text{C} \pm 1$ digit Combined with sensors; $\pm 1.0^\circ\text{C}$ (0 to 70°C), $\pm 1.3^\circ\text{C}$ (above 70°C)								
Display:	Digital LCD with backlight								
Temperature compensation:	0.00 to 10.00% /°C (reference temperature: 15 to 30°C)								
Calibration:	Conductivity/Resistivity: Automatic (2 points maximum), Manual (5 points maximum) Temperature: Manual (1 point)								
Functions:	Display conductivity or resistivity and solution temperature (simultaneously), Electrode degradation level indicator, Stability check function, Data Memory (500 points)								
Construction:	IP67								
Compatible standards:	CE, RCM								
Connectable sensor:	SC92SN								
Wetted Material:	<ul style="list-style-type: none"> ●Sensor for high purity water measurement; SUS316 (electrode element), Polypropylene resin (insulator sensor body), Fluorine rubber (O-ring), PVC (cable), Silicone rubber (sensor seal), Rigid polyethylene (grip), Nylon 6 (code bushing), Epoxy resin (sensor internal filler) ●General-purpose type sensor Titanium (sensor electrode), Polypropylene resin (sensor body and cover), Fluorine rubber (O-ring), PVC (cable), Polyphenylene sulfide resin (neck), Silicone rubber (sensor seal), Polypropylene resin (sensor body, cover), Rigid polyethylene (grip), Nylon 6 (cord bushing), Epoxy resin (sensor internal filler) ●Chemical resistant type sensor / Sensor for high conductivity measurement; Glass (sensor body), Platinum black (electrode element), PVC (cable), Silicone rubber (sensor seal), Rigid polyethylene (grip) Nylon 6 (cord bushing), Epoxy resin (sensor internal filler) 								
Ambient temperature	0 to 45°C								
Dimensions:	Approximately H160 × W80 × D40 mm (not including connector part)								
Weight:	Approximately 230 g (without batteries, sensor)								
Power source:	2 x AA Alkaline batteries (LR6) Auto power off function (time configurable: 1 to 30 minutes)								
Battery life:	Approximately 500 hours								

1.2 Instrument Check

Upon delivery, unpack the instrument carefully and inspect it to ensure that it was not damaged during shipment. If damage is found, retain the original packing materials (including the outer box) and then immediately notify YOKOGAWA sales office.

■ Checking the model and suffix code

Check the model and suffix code on the name plate affixed to the back side of the meter and sensor cable as shown in Figure 1.1 Name plate example. See Model and suffix code in 1.3 Model and Suffix Codes

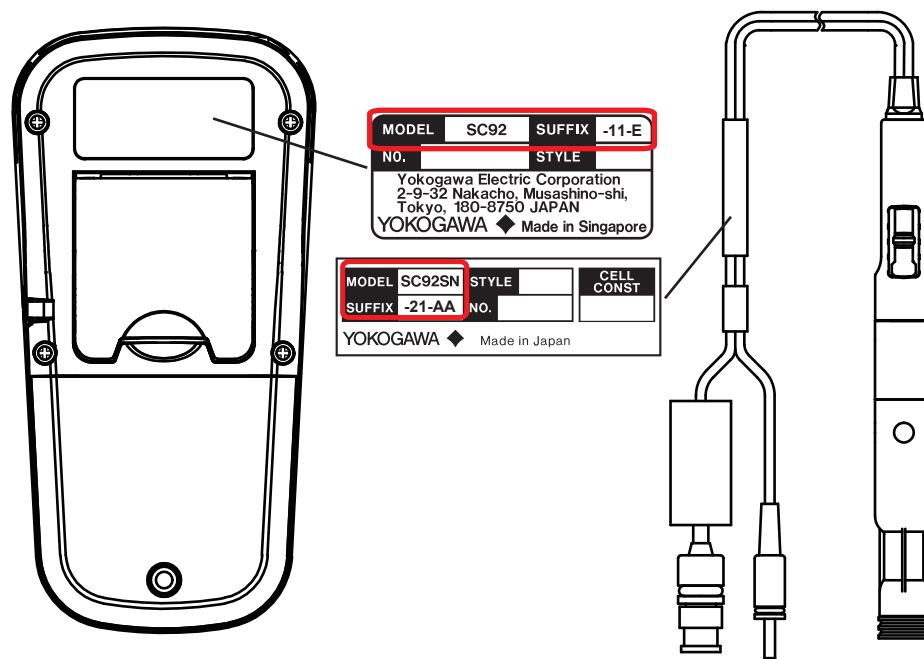

Figure 1.1 Name plate example

■ Checking package contents

Make sure the following parts as shown in Table 1.1 are included. See 1.3 Model and Suffix Codes to specify code for sensor connection.

Table 1.1 Standard accessories (✓: included)

Products	SUFFIX code for Connecting sensors					
	-00	-11	-21	-23	-31	-41
Portable conductivity meter	✓	✓	✓	✓	✓	✓
User's manual	✓	✓	✓	✓	✓	✓
Sensors	-	✓	✓	✓	✓	✓
Cotton swabs for sensor cleaning (5pcs)	-	✓	✓	✓	-	-

1.3 Model and Suffix Codes

SC92 Portable conductivity meter

Model	Suffix code	Option code	Description
SC92	Portable conductivity meter
Connecting sensors	-00	Without sensor
	-11	With sensor for high purity water measurement (cable length: 0.75 m)
	-21	With general-purpose type sensor (cable length: 0.75 m)
	-23	With general-purpose type sensor (cable length: 2.75 m)
	-31	With chemical-resistant type sensor (cable length: 0.75 m)
Country *1	-J	Japan (with Japanese manual and batteries, without standard markings)
	-E	Except Japan (with English manual and standard markings, without batteries)

*1: Always specify "-J" for orders to Japan ("-E" is not acceptable).
Always select "-E" for orders destined for outside Japan ("-J" is not acceptable).

SC92SN Conductivity sensor for portable conductivity meter

Model	Suffix code	Option code	Description
SC92SN	Conductivity sensor for portable conductivity meter
Type	-11	Sensor for high purity water measurement (cable length: 0.75 m)
	-21	General-purpose type sensor (cable length: 0.75 m)
	-23	General-purpose type sensor (cable length: 2.75 m)
	-31	Chemical-resistant type sensor (cable length: 0.75 m)
	-41	Sensor for high conductivity measurement (cable length: 0.75 m)
—	-AA	Always -AA

1.4 Part Name and Functions

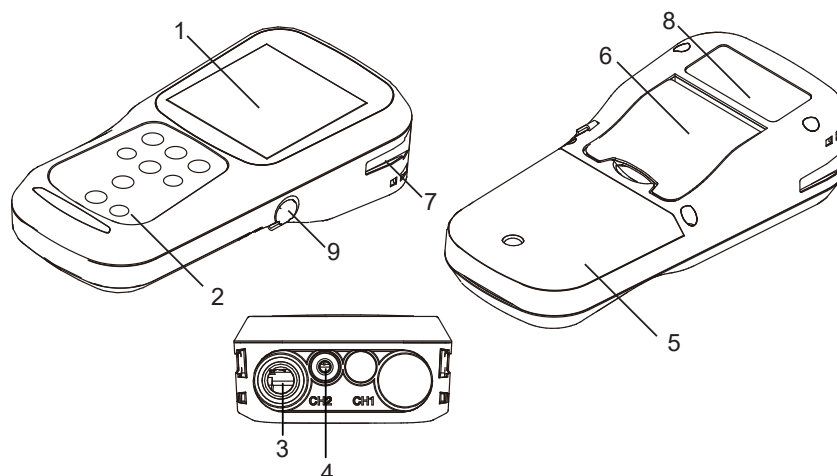

No	Name	Description
1	LCD	Displays the measured value
2	Operation keys	Used for instrument operation
3	Electrode connector	Connector for conductivity sensor, temperature connector. CH2 is used.
4	Temperature connector	
5	Battery cover	Open/close to insert/remove batteries
6	Meter stand	Put up the stand to tilt the meter, when the LCD is difficult to see. Place the meter on a flat surface.
7	Sensor holder	Hook the sensor by sliding it into the holder from the top.
8	Name plate	—
9	—	Not used

Figure 1.2 Name and functions of the meter

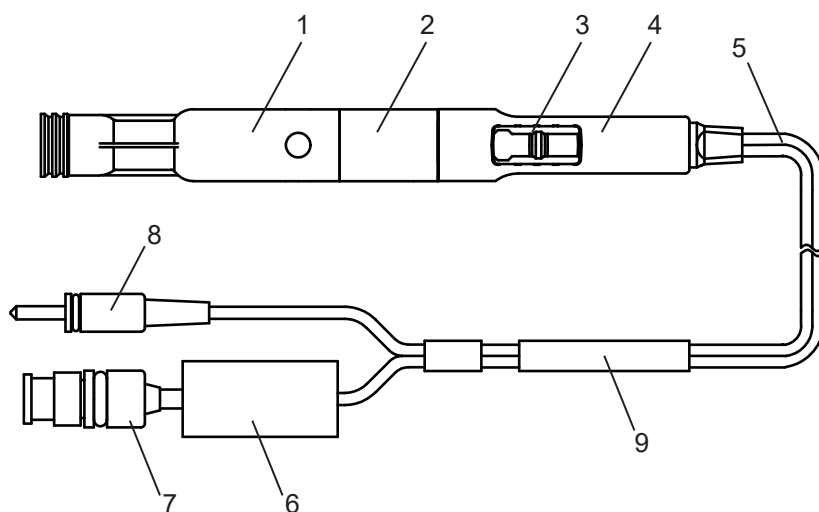

No	Name	Description
1	Protective cover	Remove only when cleaning. (only for the sensor for high purity water measurement, general-purpose sensor)
2	Sensor body	Thermal resistance 80°C plastic The material is glass for chemical-resistant type and high conductivity measurement.
3	Latch	To hold the sensor to the side of the meter. Insert the sensor into the latch from the top .
4	Sensor grip	Easy-to-hold grip
5	Sensor cable	—
6	Connector cover	—
7	Electrode connector	Connects sensors to the meter.
8	Temperature connector	Connect sensors to the meter. Normally connect to the temperature connector and measure in automatic temperature compensation (ATC) mode, but disconnect in manual temperature compensation (MTC) mode.
9	Name plate	Cell constant is written.

Figure 1.3 Name and functions of the sensor (Example as a general-purpose type)

■ Operation keys

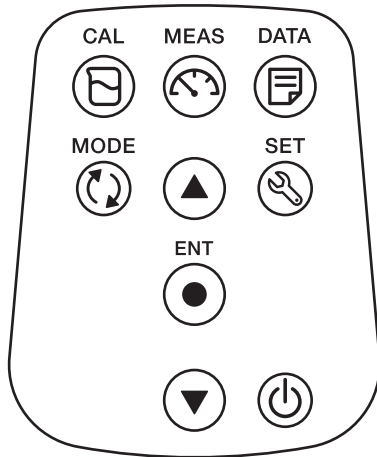

Key	Name	Function
	CAL key	Switch from measurement mode to calibration mode CAL . Calibration start in calibration mode.
	MEAS key	Switch to measurement mode MEAS from others. In automatic hold mode, the measurement value can be unfixed and a new measurement can start.
	DATA key	Switch from measurement mode to data mode DATA . Use the key to see the saved data.
	SET key	Switch from measurement mode to setting mode SET . When in a measurement mode, you will return to a previous setting. Make various settings.
	MODE key	Change the measurement parameters in a measurement mode. Switches between conductivity and resistivity.
	ENT key	Select or set items. In a measurement mode, data can be saved. When the data logging interval is set, the logging of data storage starts. (DATA is displayed when data is saved)
	up	Move between various setting items in setting mode.
	down	Used to select items on the setting screen. Increase or decrease the number when entering numbers.
	power key	Switch the main unit power supply ON/OFF.

Figure 1.4 Key name and functions

■ Display items

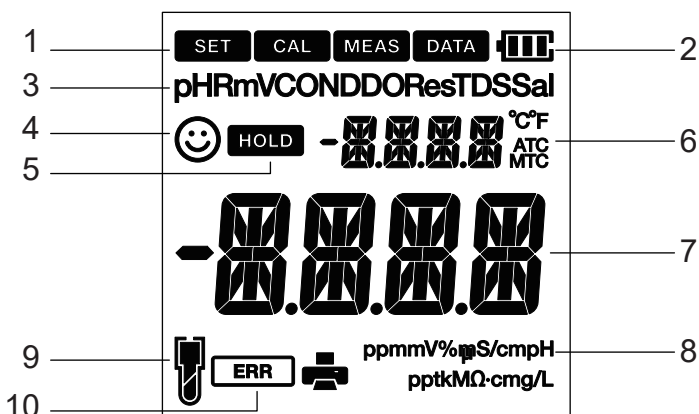

No	Function										
1	Displays the current operation mode (Setup, Calibration, Measurement, Data mode)										
2	Battery level										
	<table border="1"> <thead> <tr> <th>Icon</th> <th>Battery level</th> </tr> </thead> <tbody> <tr> <td></td> <td>100%</td> </tr> <tr> <td></td> <td>50%</td> </tr> <tr> <td></td> <td>20%</td> </tr> <tr> <td></td> <td>Low battery. Need replacement.</td> </tr> </tbody> </table>	Icon	Battery level		100%		50%		20%		Low battery. Need replacement.
	Icon	Battery level									
		100%									
		50%									
	20%										
	Low battery. Need replacement.										
BATT LOW	See ■ Error messages .										
3	Measurement items such as COND (conductivity) and Res (resistivity).										
4	Show stability. Indicates that the value is stable and can be read in auto-stability and auto-hold modes.										
5	Indicate that the measured value display is stable and the measured value is fixed in auto hold mode.										
6	Measured temperature and messages. When the temperature connector is unplugged, MTC, when plugged, ATC is displayed. (ATC: automatic, MTC: manual)										
7	Measured values, set values and messages.										
8	The units of the measurement parameter.										
9	The calibration factor level. It is not displayed if there is no calibration data.										
	<table border="1"> <thead> <tr> <th>Icon</th> <th>Average calibration factor (C.F)</th> </tr> </thead> <tbody> <tr> <td></td> <td>C.F: 0.90 to 1.11</td> </tr> <tr> <td></td> <td>C.F: 0.80 to 0.89, 1.12 to 1.25</td> </tr> <tr> <td></td> <td>C.F: 0.70 to 0.79, 1.26 to 1.43* (* 1.30 for the manual calibration)</td> </tr> </tbody> </table>	Icon	Average calibration factor (C.F)		C.F: 0.90 to 1.11		C.F: 0.80 to 0.89, 1.12 to 1.25		C.F: 0.70 to 0.79, 1.26 to 1.43* (* 1.30 for the manual calibration)		
	Icon	Average calibration factor (C.F)									
		C.F: 0.90 to 1.11									
	C.F: 0.80 to 0.89, 1.12 to 1.25										
	C.F: 0.70 to 0.79, 1.26 to 1.43* (* 1.30 for the manual calibration)										
Std ERR	Calibration factor (C.F) is out of range. See ■ Error messages to solve this. Note that the manual calibration does now show Std ERR.										
10	Errors										

Figure 1.5 Display items (The figure above shows full screen display. Some are not displayed under normal use.)

The average calibration factor is the mean value of each calibration factor calculated by the calibration. For example, if automatic calibration is performed at two points, 0.1 mol/L NaCl solution (10.67 mS/cm) and 0.001 mol/L NaCl solution (123.9 μS/cm), the average calibration factor is 0.90 if the calibration factors are 0.95 and 0.85, respectively.

1.5 Optional Accessories

Optional accessories as shown below are sold separately if necessary.

Name	Remark	Part number	Quantity	
NaCl Standard solution	0.1 mol/l NaCl solution for calibration 250 mL	K9221ZA *	1 pcs	

*: You can download the Safety Data Sheet (SDS) from the following website: <https://www.yokogawa.com/library/>.

1.6 Dimensions

SC92 meter (when the back stand is up)

Unit: mm

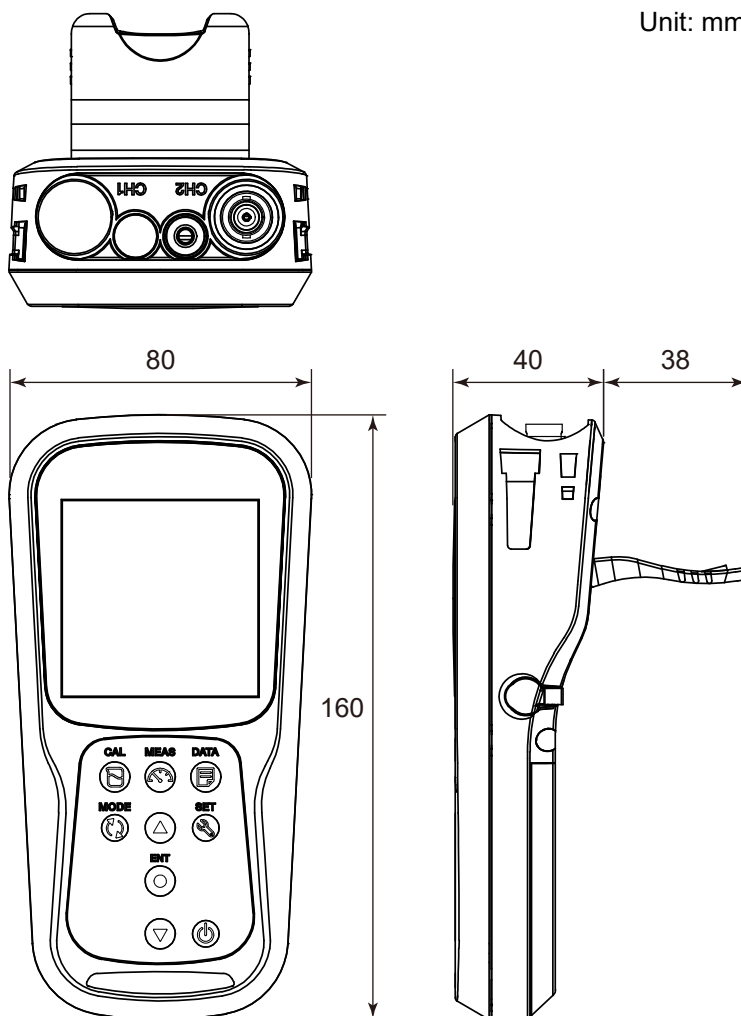

SC92SN conductivity sensor

Sensor for high purity water measurement
SC92SN-11-AA

General-purpose type sensor
SC92SN-21-AA
SC92SN-23-AA

Unit: mm

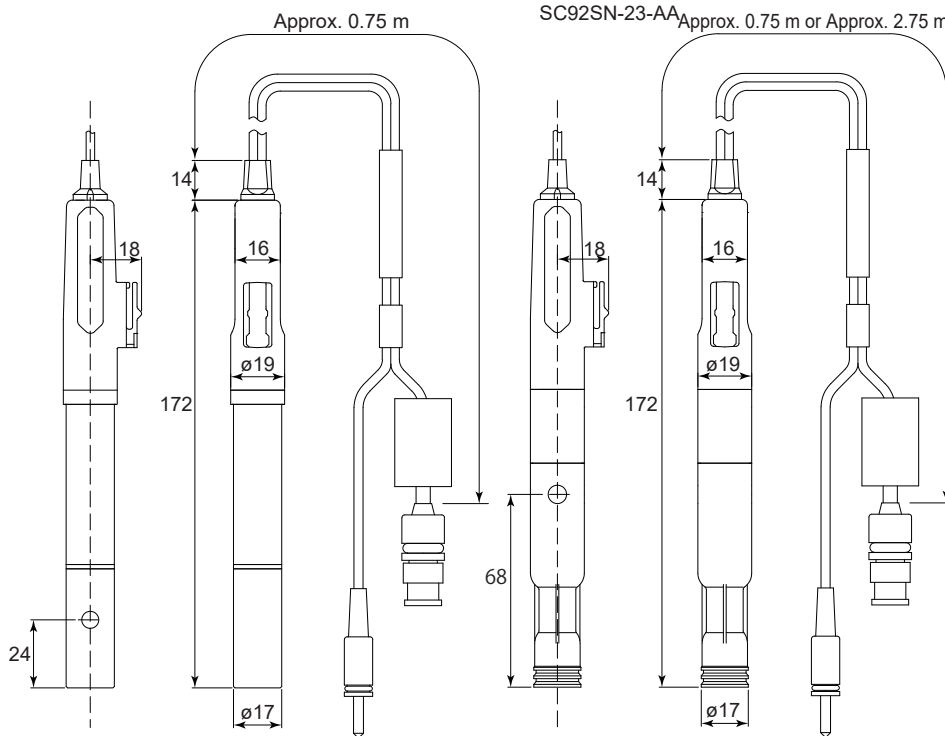

Chemical-resistant type sensor
SC92SN-31-AA

Sensor for high-conductivity measurement
SC92SN-41-AA

Unit: mm

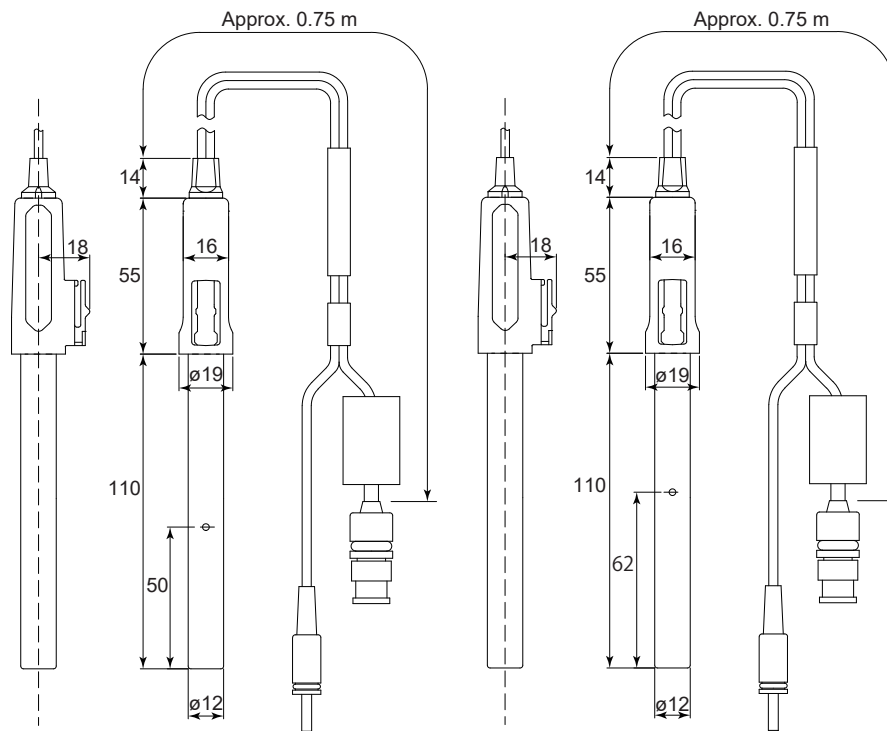

2. Basic Operations

Before use, put batteries in the meter and connect the sensor. Before starting a measurement (Chapter 3), set (Chapter 4) and calibrate (Chapter 5) to your preference as needed.

NOTE

Operate the keys with your fingers.

2.1 Inserting the Batteries

Put AA alkaline batteries into the meter.

- (1) Unscrew the battery cover on the back of the meter counter-clockwise to unlock the battery cover.
- (2) Remove the battery cover and set the batteries inside.
- (3) Put the cover back on.
- (4) Screw the battery cover on the back of the instrument clockwise to lock the battery cover.

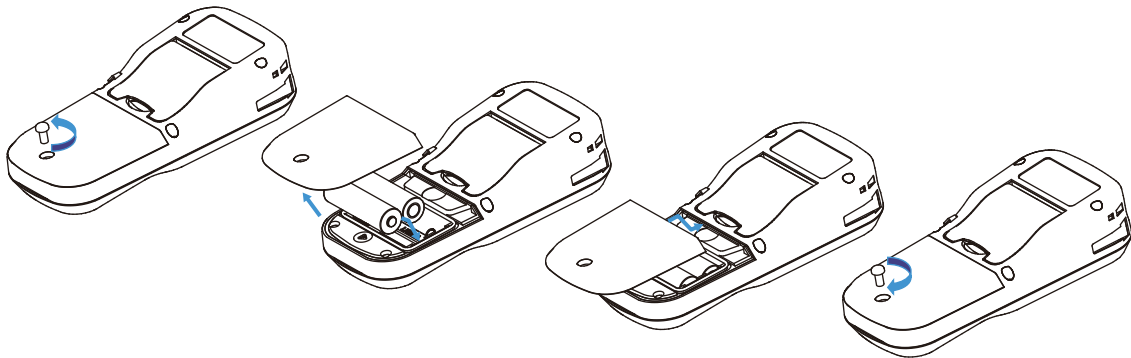



Figure 2.1 Insert battery into the meter

Power is turned on when batteries are inserted. To turn off the power, press and hold the power  key. To turn the power on again, press the power  key.



CAUTION

- When installing batteries, observe correct polarity: + (plus) - (minus). Failure to do so may damage to the meter.
- Do not use two different types of batteries or use new and old batteries at the same time.
- Do not replace the batteries in a dusty place or with wet hands. Dust or moisture could get inside the instrument and possibly cause an instrument malfunction.
- Prevent electrostatic damage when replacing batteries.
- Take care not to damage the gasket in the battery box to keep waterproof and dustproof.
- When a battery cover is replaced, make sure that the gasket is clean and correctly fitted in order to maintain the waterproof/dustproof.
- The screw for a battery cover shall be tightened with 1.2 N•m
- Loosen only the battery cover screws. Do not unscrew other screws to maintain waterproof and dustproof.

2.2 Connecting Sensor

Connect a conductivity sensor to CH2. Connectable one is SC92SN.
It is no problem to connect the sensor while the power is ON.

Connect the sensor to the meter properly as follows.

- (1) Align the slot of the electrode connector with the pin of the electrode connector on the meter and insert it. After firmly pushing it all the way in, turn the electrode connector all the way to the right.
- (2) Slide the connector cover over the connector and push the cover straight down until it lightly touches the meter body. Do not turn the cover.
- (3) Insert the temperature connector into the temperature connector on the meter. Insert the temperature connector firmly until the O-ring on the temperature connector is no longer visible.

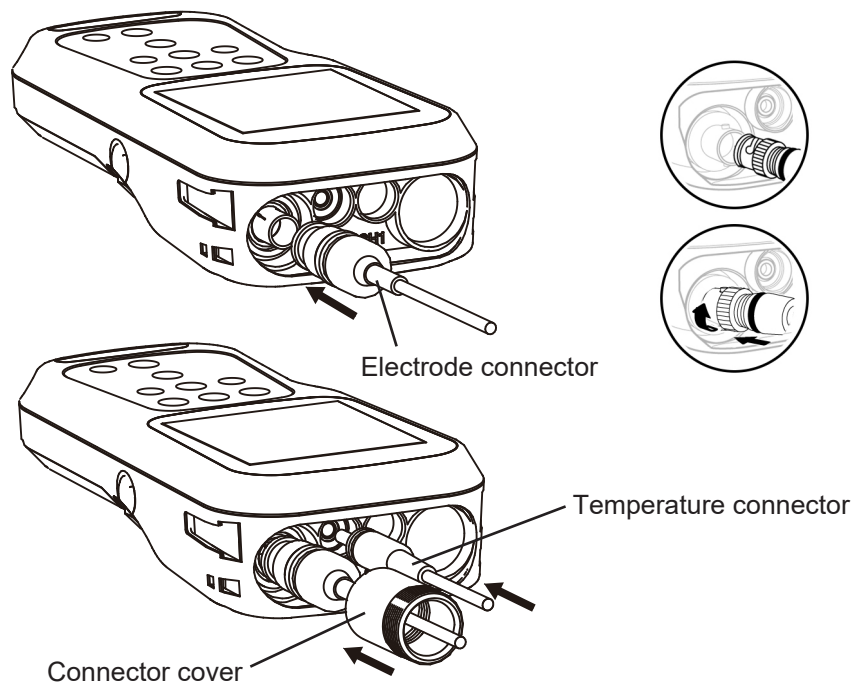

Figure 2.2 Connection with sensors



CAUTION

- Connect the sensor in a place free from moisture and dust.
- Take care not wet or contaminate the connector.
- When connecting sensors, be careful not to damage the equipment due to static electricity.
- To maintain waterproof and dustproof performance (IP67), use the cover and plug the connector properly.









Leave the sensor connected unless there is a particular need to disconnect it. When disconnecting the sensor, follow the reverse procedure of the connection. Never forcefully pull on the electrode connector. It is no problem to disconnect the sensor while the power is ON.

NOTE

- If the temperature connector is not plugged in, MTC is displayed; if it is, ATC is displayed. (page 3-3 ■ Temperature Compensation)
- IP67 is not guaranteed if the temperature connector is not plugged in.

2.3 Changing Operation Mode

You can change the operation mode to four available modes depending on the purpose of use. The status icon indicates the current mode.

Icon	Name	Function	Chapter
	Setup mode	Perform various setup Press the SET  key in the measurement mode to go to the setup mode. Press the SET  key in the setup mode to return to the previous screen.	4
	Calibration mode	Perform calibration. Press the CAL  key in the measurement mode to go to the calibration mode.	5
	Measurement mode	Perform measurement. Press the MEAS  key outside of the measurement mode to go to the measurement mode.	3
	Data mode	Display the saved data. Press the DATA  key in the measurement mode to go to the data mode.	6

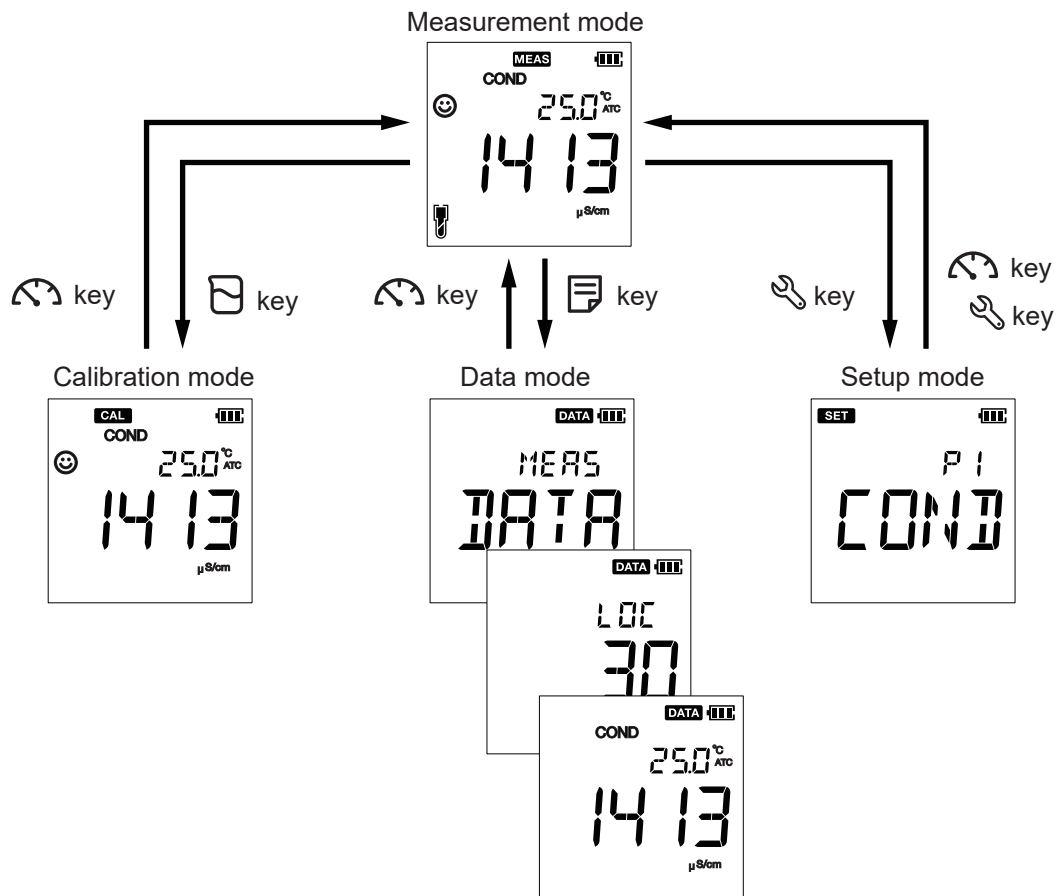

2.4 Saving Data

In a measurement mode, press the ENT ● key. **DATA** appears and the displayed data are saved. The measurement item, temperature, and measured value data are saved. The data number (LOC: location number) is displayed, then automatically the screen returns to the previous display.

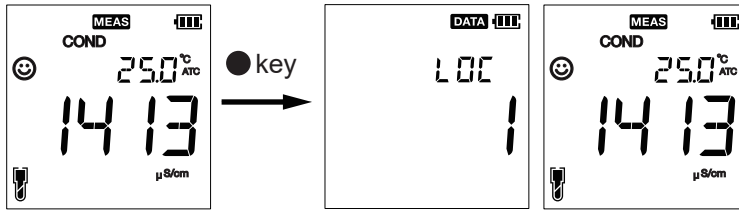

The data log function allows you to automatically save data at set time intervals. Press the ENT ● key to start/stop.(4.2.1 Data log interval setup (LOG))

NOTE

When the data storage limit (500 data) is reached, you cannot store data, an error occurs, MEM FULL :memory is full, is displayed. If you want to save new data, delete the stored data.(4.2.2 All data clear (D.Clr))

3. Measurement Mode (MEAS)

Performs measurements and **MEAS** is indicated on the screen.

If you are in any other mode, press the MEAS  key to switch to measurement mode.

To measure conductivity, cell constants must be entered into the meter. To set the cell constant, see 4.1.1 Cell constant (CELL).

In Auto Hold mode, press the MEAS  key during measurement mode to cancel HOLD **HOLD**.

● How to change the measurement parameter

SC92 can measure both conductivity and resistivity.

When in measurement mode, press the MODE  key to switch measurement parameters.

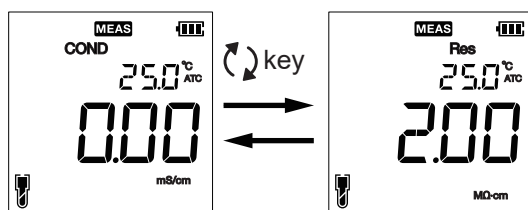

■ Precautions

- Be sure to check that the cell constants and temperature coefficients are set correctly. (Section 4.1.1)
- Make sure that the cover (for general-purpose type sensor) and the outer electrode (for sensor for high purity water measurement) are not warped.
- Do not use for measurement of solutions exceeding 80°C (50°C or lower in case of submerged above the grip section).
Do not use for measurement of highly corrosive solutions, such as solutions containing hydrofluoric acid.
- Wipe off any stains on the body with a soft object such as tissue paper. If it is extremely dirty, use neutral detergent.
- See 8. Trouble Shooting to find the cause if an abnormal phenomenon occurs during measurement.
- After the measurement is finished, wash off any dirt or measurement solution adhering to the sensor with water and store it. (Section 7.3)

If multiple sensors are in contact with each other while conducting a measurement, the measured value may not be stable. In this case, keep the sensors apart from each other.



CAUTION

The meter is made of solvent resistant materials but is not resistant to all chemicals. Do not immerse the instrument in strong acid or alkali solution, or wipe it with such solutions.

How to measure

- (1) Remove the cap of sensor when the sensor has one.
- (2) To avoid measurement errors, fully immerse the sensor in the sample until the liquid level reaches the air vent (bubble outlet).
Air bubbles on the electrode element may also cause measurement errors. Shake the sensor up and down a few times after immersing to remove bubbles.

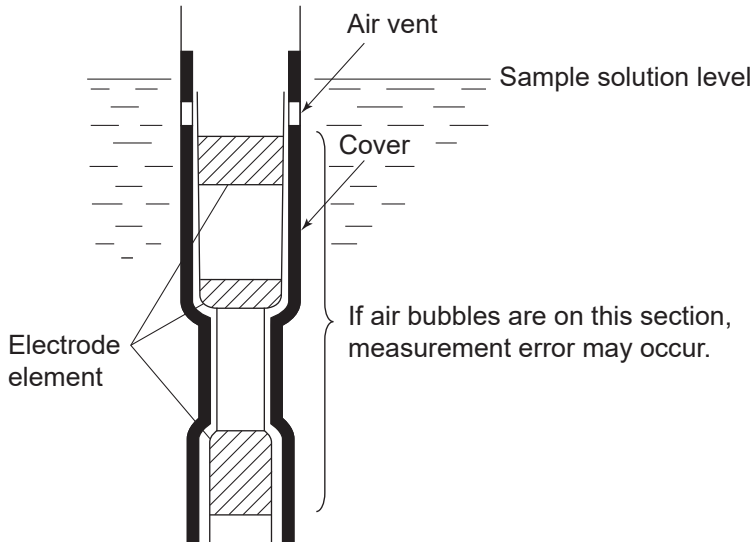

Figure 1 How to immerse sensor (general-purpose type)

- (3) In the default auto stable mode, an automatic stability check starts and ☺ flashes. When the measured value has stabilized, the ☺ switches from blinking to lit to indicate the stabilized measured value.

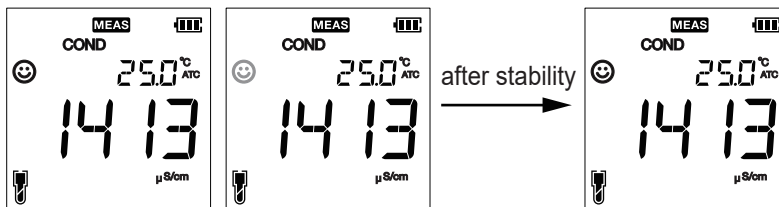

Figure 2 Conductivity measurement example (auto stable mode)

■ Temperature Compensation

There are two types of temperature compensation: automatic temperature compensation (ATC) and manual temperature compensation (MTC).

Automatic temperature compensation (ATC) measures the temperature of the solution and automatically compensates for it by connecting the temperature sensor (temperature connector) built into the sensor to the meter.

The instrument normally uses a temperature sensor built into the sensor to measure the temperature of the solution for automatic temperature compensation (automatic temperature compensation (ATC)), but manual temperature compensation (manual temperature compensation (MTC)) is also possible using a solution of known temperature.

When the temperature connector is disconnected, manual temperature compensation (MTC) is automatically activated.

Manual temperature compensation (MTC) is performed by measuring the temperature of the solution beforehand and manually entering the temperature value without connecting a temperature sensor (temperature connector) to the meter.

To manually input the temperature of the solution measured in advance, follow the same procedure as (2) to (6) in "5.2 Temperature Calibration". Be sure to disconnect the temperature connector, and in (4), input the temperature you wish to set instead of the temperature to be calibrated. It is not necessary to immerse the sensor in the solution.

4. Setup Mode (SET)

Set up various settings. Press the SET  key to go to the setup mode. **SET** is displayed.

NOTE

Press the MEAS  key to return to measurement mode after setting.

In the setup mode (**SET** is displayed), press the SET  key to return to the previous screen.

4.1 Conductivity Setup (COND)

Using Conductivity setup function, you can:

- Setting Cell Constants
You can set the cell constants shown on the conductivity electrode.
- Select conductivity unit
The unit of measurement for conductivity can be selected.
- Calibration mode setting
 - Automatic: Each standard solution is automatically detected and calibrated.
 - Manual: Calibration is performed by setting an arbitrary calibration value.
- Temperature compensation factor setting
Set the coefficient to convert to a conductivity value at a set reference temperature (default setting: 25°C).
- Reference temperature setting
Set the reference temperature of the measured value to be displayed when converting temperature.
- Clear Calibration Data
Delete calibration data.

4.1.1 Cell constant (CELL)

Set the cell constant. The setting range is 0.010 to 20.00 cm⁻¹.







The cell constant varies from sensor to sensor even if they are of the same type (standard cell constant is the same). So the unique cell constants of the sensor to be used must be set. Set the cell constant indicated in the model name and cell constant shown on the sensor cable.

Also, be sure to set the cell constants when replacing the sensor with a new one.

Once a cell constant is set, it is stored in memory even after the battery is replaced.

NOTE





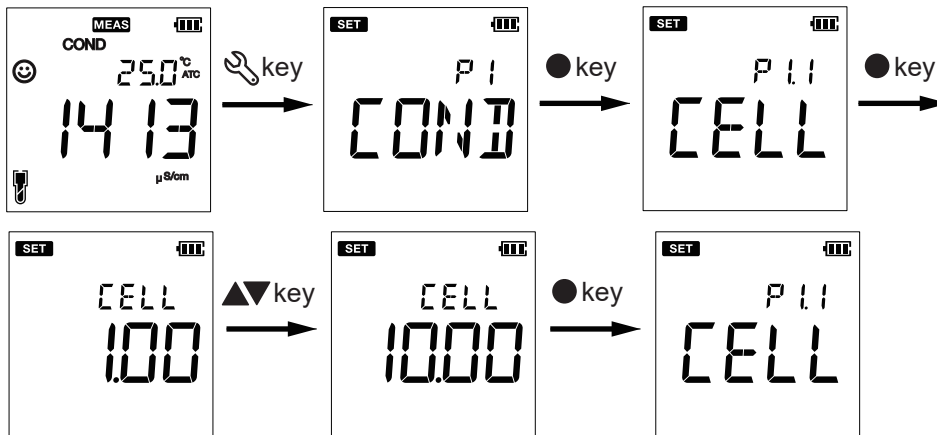

If calibration is performed without entering the correct cell constants, the calibration coefficients will not be correct.

- (1) Press the SET .key
- (2) When P1 COND screen appears, press the ENT  key.
- (3) When P1.1 CELL screen appears, press the ENT  key.
- (4) Use   to change the cell constants, press the ENT  key to confirm. P1.1 CELL screen appears.



4.1.2 Unit (UNIT)

Select the unit of conductivity. Select from S/cm (default) or S/m.

- (1) Press the SET  key.
- (2) When the P1 COND screen appears, press the ENT  key.
- (3) When the P1.1 CELL screen appears, press the up  key once to go to the P1.2 UNIT screen and press the ENT  key.
- (4) Select unit by pressing  , and press the ENT  key to confirm. P1.2 UNIT screen appears.

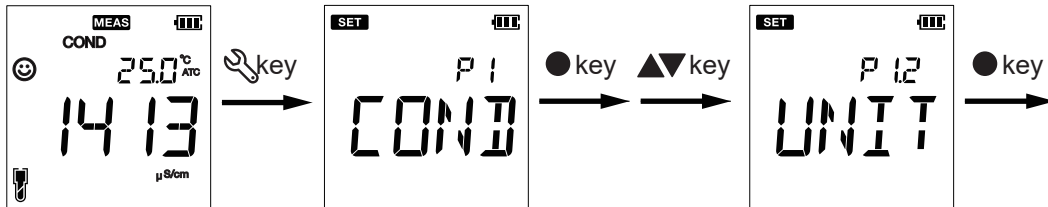



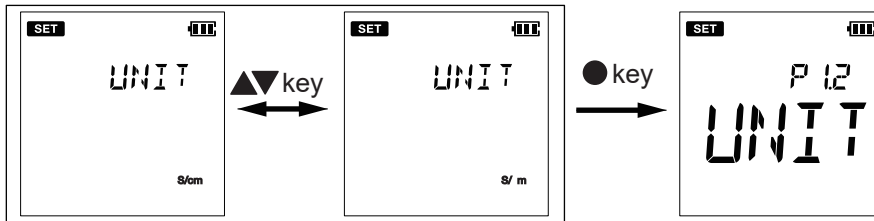



Select the unit



4.1.3 Auto calibration (A.CAL)

Set whether or not automatic calibration is performed.

The default setting is ON (automatic calibration). To perform manual calibration, the setting must be changed to OFF.

- (1) Press the set  key.
- (2) When the P1 COND screen appears, press the ENT  key.
- (3) When the P1.1 CELL screen appears, press the up  key two times to go to the A.CAL screen and press the ENT  key.
- (4) Press   to select ON/OFF and the ENT  key. The P1.3 A.CAL screen appears.

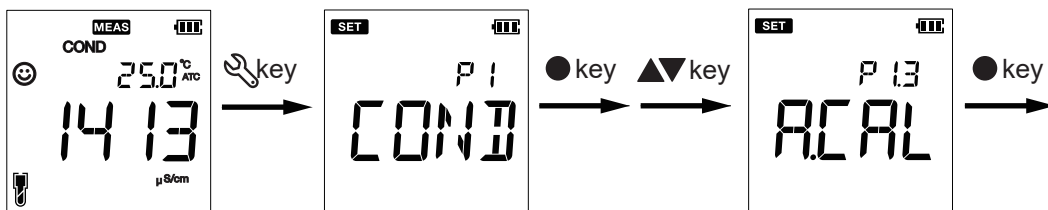

Select whether or not automatic calibration

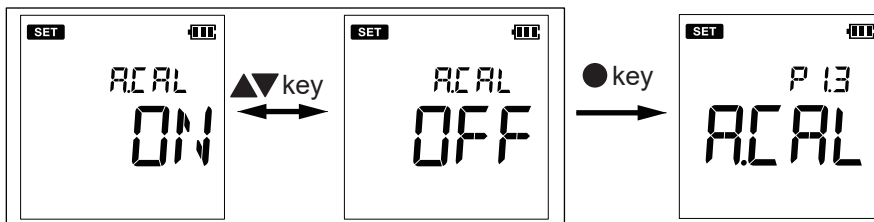

4.1.4 Temperature compensation factor (T.CFF)

Temperature characteristics of conductivity depend on solution.

The temperature compensation factor can be set according to the solution to be measured.

Set the temperature compensation factor. The setting range is 0.00 to 10.00 %°C. The default is 2.00 %°C.

When set to 0.00 %°C, a value without temperature compensation can be measured.

When using NaCl solution, the temperature compensation factor is 2.00 %°C, so use the default value.

Table 4.1 shows the conductivity ratio of NaCl (sodium chloride) solution at various temperatures when the conductivity at 25°C is set to 1.







Table 4.1 Conductivity ratio in NaCl solution at each temperature (25°C as 1)

0°C	25°C	50°C	75°C	100°C
0.542	1	1.531	2.103	2.677

The temperature compensation factors for various electrolyte solutions are shown in Table 4.2.

Table 4.2 Temperature Compensation Factors of Various Electrolyte Solutions

Type of electrolyte solution	Temperature compensation factor (%/°C)		
	1 mol/L	1/10 mol/L	1/1000 mol/L
Lithium benzoate solution	—	2.28	2.28
Sodium acetate solution	2.20	2.20	2.20
Potassium chloride solution	1.74	—	1.98
Sodium hydroxide solution	1.74	—	1.87
Sulfuric acid	1.07	—	1.38

- (1) Press the set  key.
- (2) When the P1 COND screen appears, press the ENT  key.
- (3) When the P1.1 CELL screen appears, press  three times to go to P1.4 T.CFF screen. Press the ENT  key.
- (4) Press  to set the temperature factor and press the ENT  key to confirm. The P1.4 T.CFF screen appears.

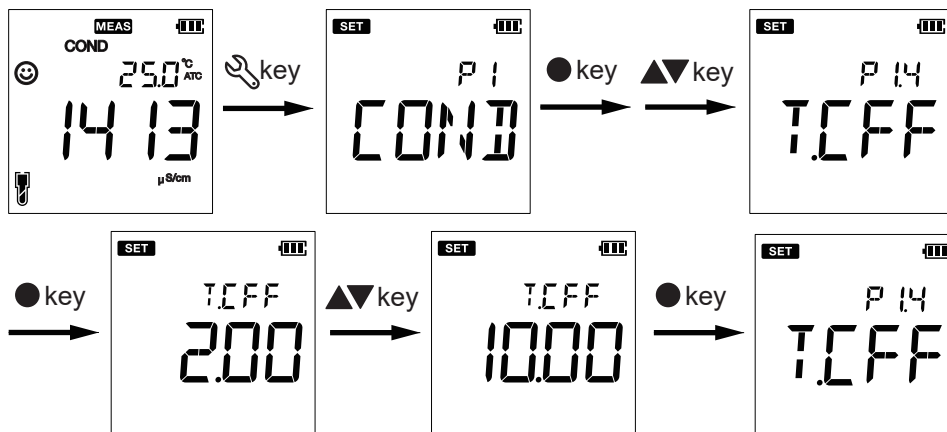

● **What is temperature compensation factor**

The conductivity of a solution varies depending on the temperature of the solution, even if it is the same solution.

Table 4.1 shows the conductivity ratios of NaCl (sodium chloride) solutions at various temperatures when the conductivity at 25°C is set to 1.

To compare concentrations, conductivity at a certain temperature (reference temperature) is required.

SC92 can measure the temperature of the solution with an embedded temperature sensor and automatically convert it to the reference temperature.

● **How to obtain temperature compensation factor**

If the temperature compensation factor of the solution to be measured is unknown, set the temperature compensation factor to 0.00, measure the conductivity at two liquid temperatures in the range of approximately 10 to 30°C, and approximate it by the following formula.

$$\text{T. CFF } \alpha = \frac{K_2 - K_1}{K_1(t_2 - 25) - K_2(t_1 - 25)} \times 100 \text{ (\%/}^\circ\text{C)}$$

where t_1, t_2 : liquid temperature (°C)
 K_1 : conductivity at t_1
 K_2 : conductivity at t_2

[Example calculations]

The following is the calculation to seek the temperature compensation factor for a solution that shows a conductivity of 124.5 μS/cm when the liquid temperature is 18.0°C and a conductivity of 147.6 μS/cm when the liquid temperature is 31.0°C.

Substituting $t_1 = 18.0$, $t_2 = 31.0$, $K_1 = 124.5$, and $K_2 = 147.6$ into the above equations,

$$\begin{aligned} \alpha &= \frac{147.6 - 124.5}{124.5 \times (31.0 - 25) - 147.6 \times (18.0 - 25)} \times 100 \\ &= \frac{23.1}{747.0 - (-1033.2)} \times 100 \\ &= 1.298 \end{aligned}$$

we obtain the value 1.298. Set the value to 1.298.

● **Confirmation of Good/Failure**

If the temperature compensation factor you set is accurate, the displayed conductivity should show a constant value regardless of the liquid temperature.

Change the temperature of the solution to check that the temperature compensation factor has been set almost accurately.







If the conductivity reading increases when the solution temperature is lowered, the temperature compensation factor is set too small. If the conductivity measurement value becomes smaller, it is because the temperature compensation factor is set higher.

In such cases, change the setting value so that the measured value does not change.

4.1.5 Reference temperature (T.rEF)

Set the reference temperature. The setting range is 15.0 to 30.0°C. The default is 25.0°C.





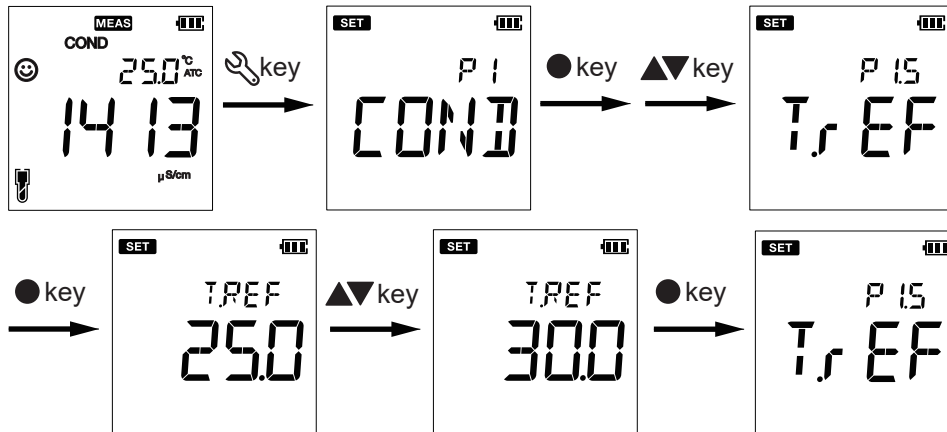

SC92 has a reference temperature conversion function that allows conversion to a set reference temperature.

- (1) Press the SET  key.
- (2) When the P1 COND screen appears, press the ENT  key.
- (3) When the P1.1 CELL screen appears, press the up  key four times to go to P1.5 T.rEF screen. Press the ENT  key.
- (4) Press   to set the reference temperature and press the ENT  key to confirm. The P1.5 T.rEF screen appears.



4.1.6 Calibration data clear (C.CLR)

Delete calibration data.

- (1) Press the SET  key.
- (2) When the P1 COND screen appears, press the ENT  key.
- (3) When the P1.1 CELL screen appears, press the up  key five times to the enter P1.6 C.CLR screen. Press the ENT  key.
- (4) A confirmation screen of (C.CLR) appears. If you want to delete, press   to go to YES screen and press the ENT  key to confirm. The P1.6 C.CLR screen appears immediately.

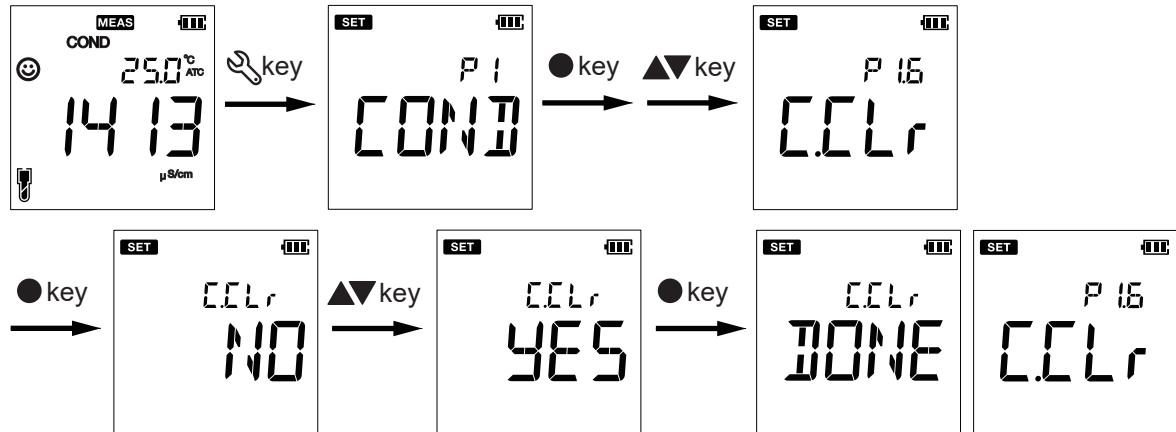

4.2 Data Setup (DATA)

Using Data setup function of the meter, you can:







- Set data log interval
- Erase data log

4.2.1 Data log interval setup (LOG)

The Data Log function allows you to automatically save data at time intervals set here. You can set the time interval from 2 to 999 seconds. The default value is “----” (no data logging interval set).

NOTE

If the data logging interval is set to a value other than “----”, auto power off (Section 4.3.2) is disabled. Power of the unit will remain on until the switch is turned off. Be aware of battery consumption.

- (1) Press the SET  key.
- (2) When the P1 COND screen appears, press the up  key once to enter the P2 DATA screen and press the ENT  key.
- (3) When the P2.1 LOG screen appears, press the ENT  key.
- (4) Press  to display the data log interval and press the ENT  key to confirm. The P2.1 LOG screen appears.

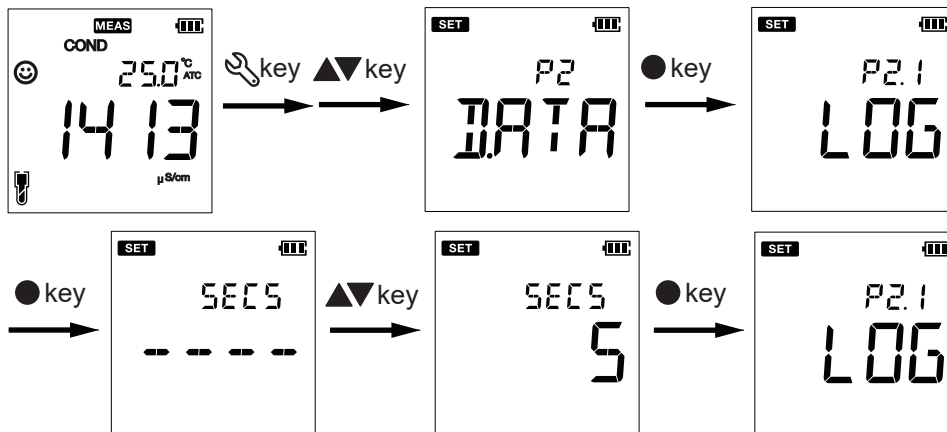









NOTE

Press the ENT  key in measurement mode to start the first data log. (DATA blinks) Press again to stop.

4.2.2 All data clear (D.CLr)

Erase all stored data.

- (1) Press the SET  key.
- (2) When the P1 COND screen appears, press the up  key once to go to P2 DATA screen and press the ENT  key.
- (3) When the P2.1 LOG screen appears, press the up  key once to go to P2.2 D.CLr screen, and press the ENT  key.
- (4) When the confirmation screen for deleting all stored data (D.CLr) appears, if you want to delete the data, press   to go to the YES screen and press the ENT  key. DONE is displayed and the P2.2 D.CLr screen appears immediately.

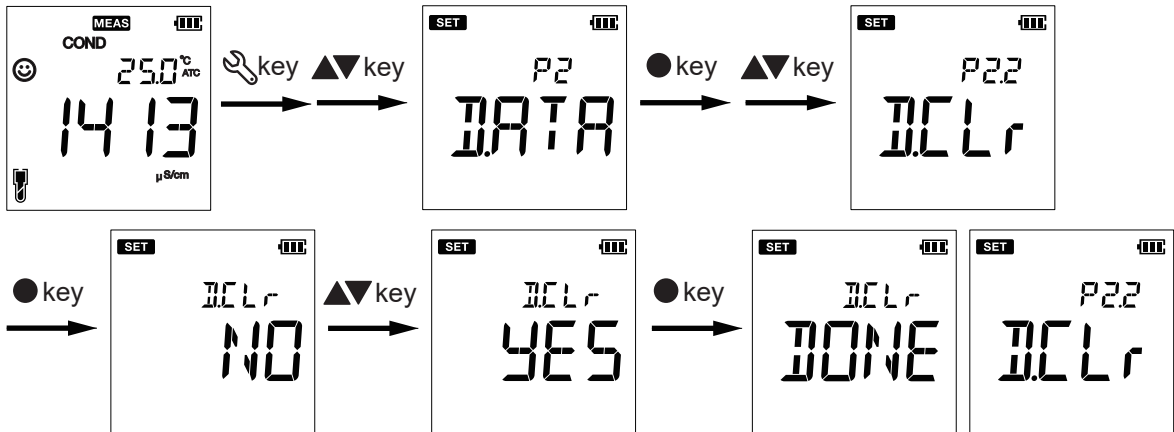

4.3 General setup (GEN)

Using the general setup function of the meter, you can:

- Set stability diagnostic mode
- Set auto power-off time
- Reset the meter

4.3.1 Stability check (STBL)

Set auto stable mode, auto hold mode, and real time mode for stability evaluation.

Mode	State
AS (Auto Stable)	When the measured value meets the stability criteria, the ☺ will change from blinking to lit and the measured value will be fixed. If the value falls outside the stability criteria, the ☺ will blink again.
AH (Auto Hold)	The measured value is fixed at the point of stability and is displayed until the hold is released. ☺ will blink until the measured value stabilizes, then HOLD and ☺ will light up. To cancel HOLD , press the MEAS  key. When the value become stabilized again, HOLD will be displayed. HOLD can also be cancelled if you proceed from the measurement mode to other modes such as the setting mode.
RT (Real Time)	Measured values are displayed in real time. Not perform stability check.

- (1) Press the SET  key.
- (2) When the P1 COND screen appears, press the up ▲ key twice to go to the P3 GEN screen and press the ENT ● key.
- (3) When the P3.1 STBL screen appears, press the ENT ● key.
- (4) Press ▲▼ to display AS (Auto Stable), AH (Auto Hold) or RT (Real Time) and press the ENT ● key to confirm. P3.1 STBL screen appears.

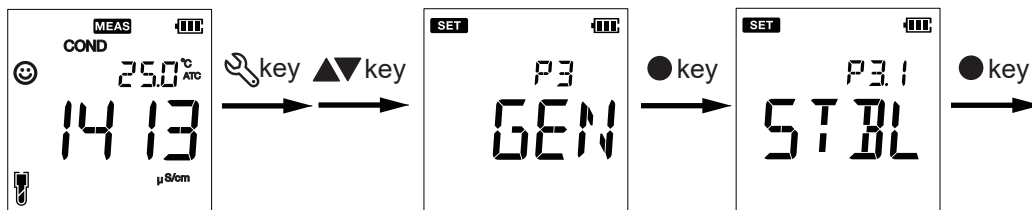

Select the Mode

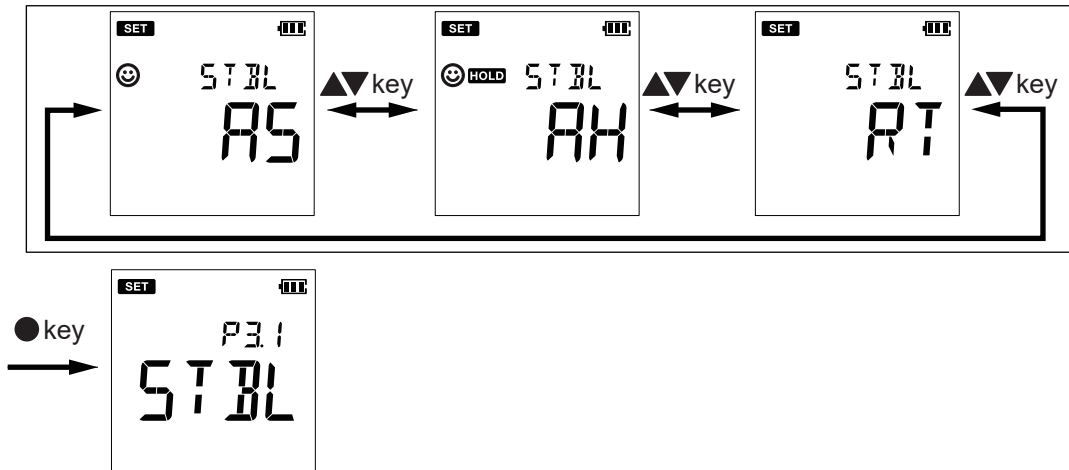

NOTE

The criteria for judging stability during Auto stable and Auto hold are as follows.

- Conductivity : change of displayed value within 2 digits in 10 sec.
- Resistivity : change of displayed value within 2 digits in 10 sec.

4.3.2 Auto power-off time setup (A.Off)







Set the time to automatically turn off the power (auto power off) when no key operation is performed for a certain period of time.

The time can be set from 1 to 30 minutes. The initial value is 30 minutes.

Setting "----" disables the auto power off function, but the power of the unit will remain on until the switch is turned off. Be aware of battery consumption.

NOTE

- If the data logging interval (4.2.1) is set to a value other than "----", auto power off (4.3.2) is disabled.
- When the data storage limit (500 data items) is reached, the data logging function automatically stops and the auto power off function is enabled.



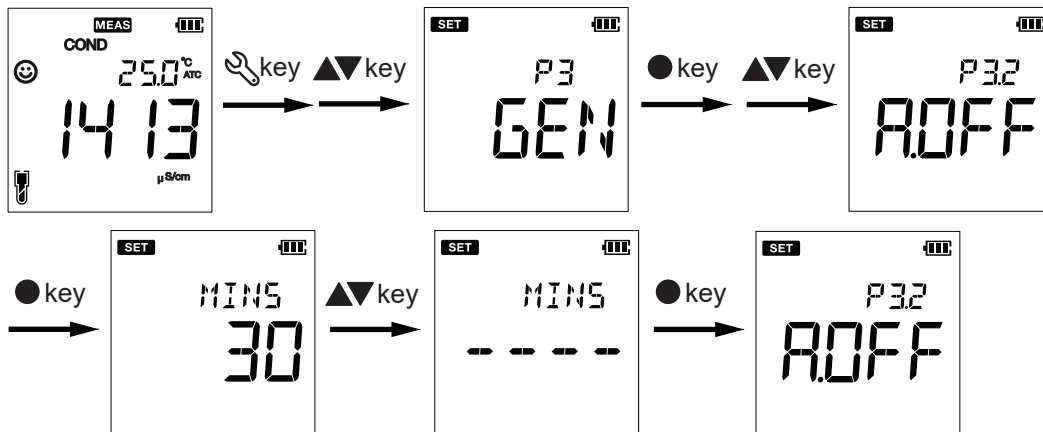





- (1) Press the SET  key.
- (2) When the P1 COND screen appears, press the up  key twice to go to the P3 GEN screen and press the ENT  key.
- (3) When the P3.1 STBL screen appears, press the key, then the P3.2 A.OFF screen appears. Press the ENT  key.
- (4) Press  to display the auto power-off time and press the ENT  key to confirm. P3.2 A.OFF screen is displayed.



4.3.3 Reset the meter (r.SET)

Reset to factory default settings.

The power is automatically turned off after the resetting.

- (1) Press the SET  key.
- (2) When the P1 COND screen appears, press the up  key twice to go to the P3 GEN screen and press the ENT  key.
- (3) When the P3.1 STBL screen appears, press the up  key twice to go to the P3.3 r.SET screen and press the ENT  key.
- (4) When the reset (RSET) confirmation screen appears, if you want to reset, press   to go to the YES screen and press the ENT  key. DONE is displayed and the power turns off automatically.

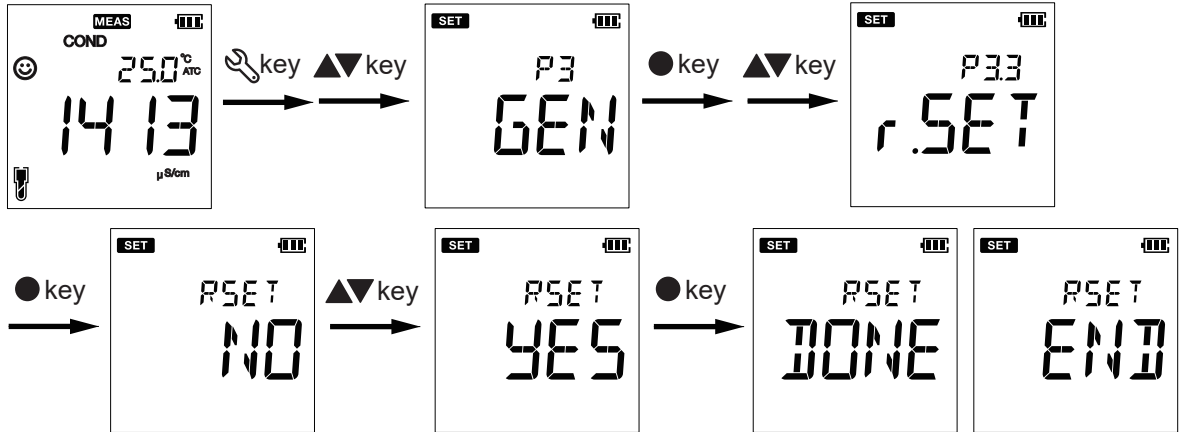

5. Calibration Mode (CAL)

In the calibration mode, Auto Stable mode (AS) is activated. Even when Stability check mode of the measurement mode is set to “Auto Hold” (AH) or “Real Time” (RT), the calibration mode forces the unit into the Auto Stable mode (AS).

NOTE

Press the MEAS  key during calibration (CAL on display) to suspend the calibration process in progress.

5.1 Standard Solution Calibration

If the sensor is no longer able to maintain normality after prolonged use, it is recommended to perform a calibration using standard solution to check if the cell constants have changed.

■ Notes on Standard Solution Calibration

For automatic calibration, prepare NaCl (sodium chloride) solution. 0.1 mol/L NaCl solution is available as an optional accessory. (Section 1.5)

For manual calibration, prepare a liquid with known conductivity, such as KCl (potassium chloride) solution.

● NaCl standard solution

When using NaCl standard solution, the temperature compensation factor is 2.00 %/°C. So use the default value. See 4.1.4 Temperature compensation factor (T.CFF).

If a sensor for high purity water measurement is used, dilute this solution 100 times with pure water at 1 μS/cm or less to make a 0.001 mol/L NaCl solution.

The conductivity is as follows

0.1 mol/L NaCl standard solution:	10.67 mS/cm at 25°C
0.001 mol/L NaCl standard solution:	123.9 μS/cm at 25°C

● KCl standard solution

KCl standard solution should be prepared by the method shown in Table 5.1.

Table 5.1 Preparation of KCl standard solution and its conductivity (according to JIS K 0102)

KCl standard solution	Preparation method	KCl standard solution (μS/cm)		
		0°C	18°C	25°C
A	Dissolve 74.2460g of KCl in water to 1 liter at 20±1°C.	65176	97838	111342
B	Dissolve 7.4365 g of KCl in water and make up to 1 liter at 20±1°C.	7138	11167	12856
C	Dissolve 0.7440 g of KCl in water to make 1 liter at 20 ± 1°C.	773.8	1220.5	1408.8
D	Dilute 100 mL of Standard Solution C with water to 1 liter at 20 ± 1°C.	—	—	146.93

● How to prepare for calibration

Prepare solution required for calibration.

It is recommended to erase previous calibration data before calibration. It is not necessary if the same calibration as the previous one is performed, as it will be overwritten. See 4.1.6 Calibration data clear (C.CLr) for information on how to erase calibration data.

See 6. Data Mode (DATA) on how to confirm the calibration data.

NOTE

When calibrating multiple points, first calibrate with a solution of low conductivity and then with one of high conductivity. Calibration in the reverse order may result in incorrect calibration, because if the sensor is not cleaned enough, the residual high conductivity solution will dissolve into the low conductivity solution and change the conductivity of the low conductivity solution.





■ **How to perform calibration**

NOTE

In conductivity calibration mode, the default setting of the calibration method is automatic calibration. For information on how to change to manual calibration, see 4.1.3 Auto calibration (A.CAL).

Set the meter to COND (conductivity measurement) mode. For resistivity measurements, the sensor is also calibrated using its conductivity.
See page 3-2 ■ How to measure on how to immerse the conductivity sensor into the solution.

● **Auto calibration**

1. After immersing the conductivity sensor in the solution, press the CAL  key.
2. The calibration method (AUTO) being set is displayed.  blinks, and the stability check of the measured value begins.
3. Wait until the value stabilizes:  goes from blinking to lit.
4. Press the ENT  key to confirm and save calibration data.
5. Meter displays DONE indicating end of the calibration procedure.
6. When calibrating two or more points, repeat steps 1 through 5 above as necessary.

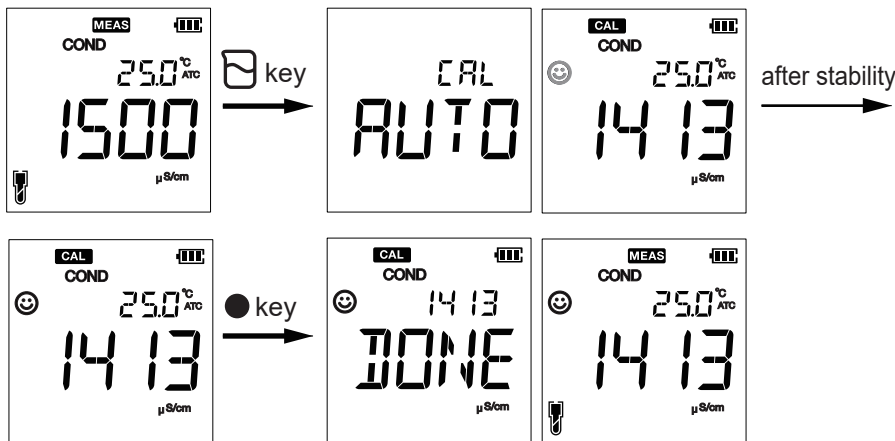





When automatically calibration is performed with a 0.1 mol/L NaCl solution (10.67 mS/cm), the calibration factor obtained from this calibration is used for all range measurements.
If calibration data are not erased and automatic calibration is performed with a 0.001 mol/L NaCl solution (123.9 µS/cm), the two calibration factors calculated for each solution are used for the measurement.

The two calibration factors used are automatically switched depending on the measured value. If the measured value is less than [2 mS/cm × cell constant (cm⁻¹)], the calibration factor obtained from the automatic calibration of 0.001 mol/L NaCl solution (123.9 µS/cm) is used, and if it is greater than [2 mS/cm × cell constant (cm⁻¹)], the calibration factor obtained from the calibration of 0.1 mol/L NaCl solution (10.67 mS/cm) is used. The calibration factor obtained from the calibration of 0.1 mol/LNaCl solution (10.67 mS/cm) is used.

If the calibration data is not erased and automatic calibration is performed again with either solution, it will be replaced by the calibration factor at that time.

● **Manual calibration**

1. After immersing the conductivity sensor in the solution, press the CAL  key.
2. The calibration method (MAN) being set is displayed. , and the stability check of the measured value begins.
3. Wait until the value stabilizes:  goes from blinking to lit.
4. Press  to enter the conductivity value (at reference temperature) of the standard solution to be used for calibration.
5. Press the ENT  key to confirm and save calibration data.
6. Meter displays DONE indicating end of the calibration procedure.
7. When calibrating two or more points (up to 5 points), repeat steps 1 through 6 above as necessary.

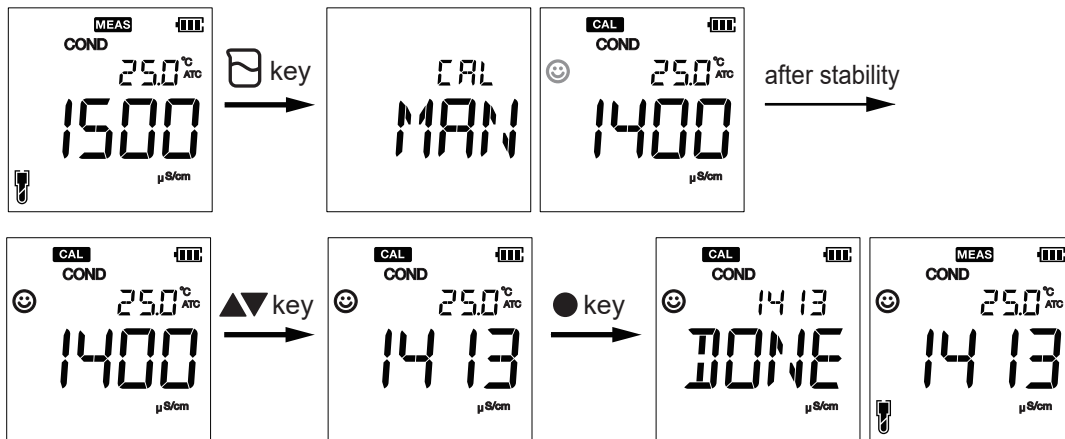





NOTE

Enter the conductivity value of the standard solution at the reference temperature. If the reference temperature is the default setting of 25°C, enter the conductivity value of the standard solution at 25°C. For setting the reference temperature, see 4.1.5 Reference temperature (T.rEF).

5.2 Temperature Calibration

Temperature calibration can be performed in automatic temperature compensation (ATC) mode. After immersing the sensor to be calibrated in temperature-controlled water in a thermostatic bath, adjust the sensor's temperature to match that of a reliable thermometer.

Always perform the temperature calibration with the temperature connector connected.

1. Immerse the conductivity sensor in the solution. Wait for 5 minutes until the temperature stabilizes.
2. Press the CAL  key to enter the calibration mode.
3. Press the MODE  key to display CAL TEMP and switch to temperature calibration mode. The current temperature is displayed on the upper line of the screen.
4. Press  to adjust the temperature shown in the lower part of the screen to the temperature to be calibrated.
5. Press the ENT  key to confirm.
6. DONE is displayed to indicate that the procedure has been completed.

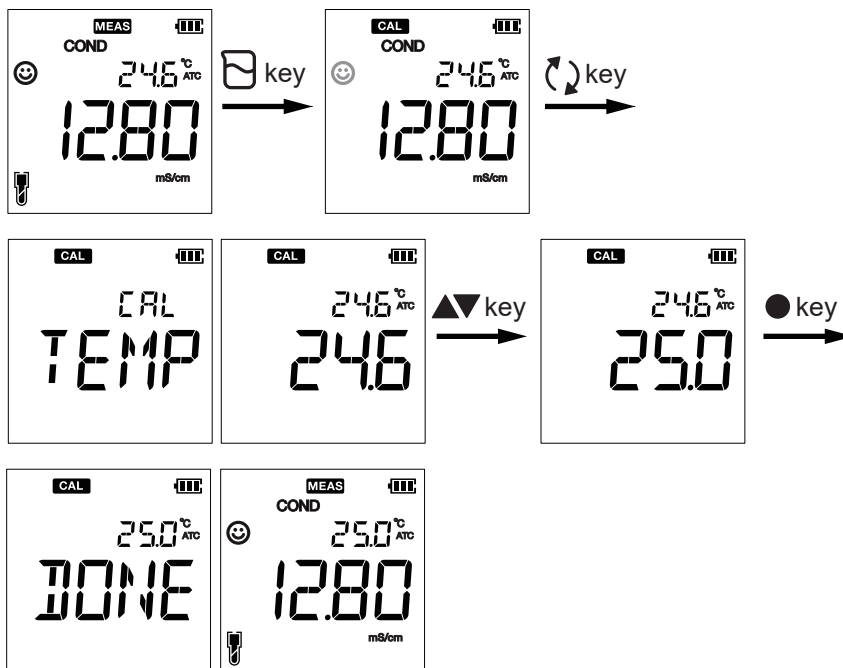

In the manual temperature compensation (MTC) mode, you can manually enter the pre-measured temperature of a solution using the above procedure. (page 3-3 ■ Temperature Compensation)

6. Data Mode (DATA)

In the data mode, you can check the data (measurement data and calibration data) stored in the internal memory.



See 2.4 Saving Data on how to save measurement data.

How to check saved data

Press the MEAS  key to return to the measurement mode.

Measurement data

Press the DATA  key during a measurement mode to display the saved data. You can check the data in order of data number (LOC: Location number).

The figure below shows that the latest stored data (LOC5) is displayed first. Press the down  key to see the previous data (LOC4). Press the up  key to see the first data (LOC1).

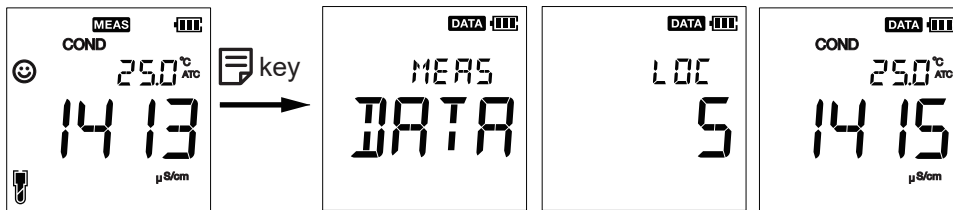

Figure 6.1 Confirmation on measurement data

Calibration data

Press the DATA **DATA** key during a calibration mode to check the calibration data.

The display switches to the calibration value display, showing the number of calibration points, calibration point*, calibration factor (CF).

*: Calibration points are indicated in order of ascending order of conductivity from low to high.

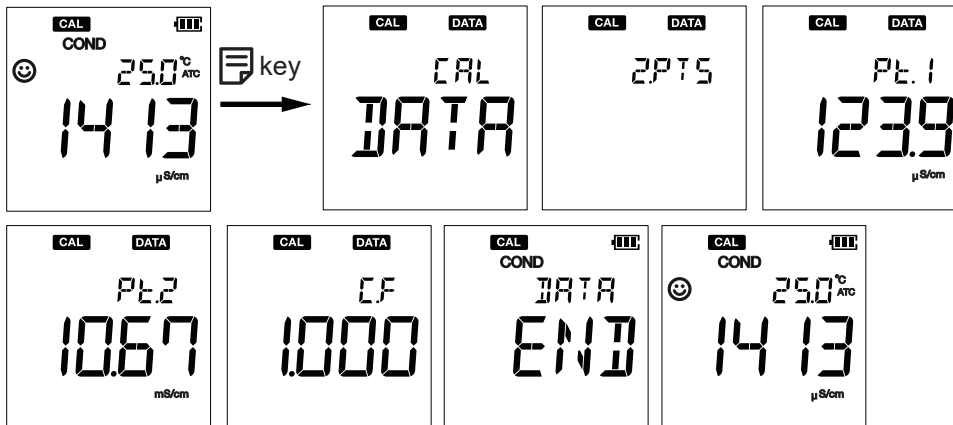

Figure 6.2 Confirmation on calibration data (example for 2 calibration points)

When no calibration data is stored, NO_CAL appears on display.

7. Storage and Maintenance

This section describes storage and maintenance of the meter and conductivity sensors.



CAUTION

- Do not leave expired batteries in the meter. The batteries may leak and cause the instrument to fail or not operate properly.
- Remove the batteries when storing the instrument unused for an extended period of time.
- Do NOT leave the instrument in direct sunlight or in a hot and humid place such as inside a car for a long period of time.

7.1 Storage

■ Storage location

Select a location where the ambient temperature and humidity are within the following equipment specifications.

Temperature: 0 to +45 °C

Humidity: under 80% relative humidity and free from condensation

Avoid the following conditions.

- Dusty area
- Strong vibration
- Direct sunlight
- Corrosive gas environment
- Locations close to an air-conditioner
- Direct wind

■ How to store

Improper storage may cause malfunction. Store with the following precautions.

- Do not leave the sensor with the sample solution stained on it. Wash off the sample solution before storing it.
- Keep the sensor connected to the meter as much as possible. This will prevent the degradation of insulation resistance at the connector and prevent contamination of the O-ring for water proofing.
- Do not place any objects on the sensor as well as the meter itself.

7.2 Meter Maintenance

■ How to clean the meter

- When the meter is dirty, wipe it off gently with a soft, dry cloth. If the stain is severe, wipe it off gently with a cloth moistened with alcohol.
- Although the body is made of solvent-resistant materials, it is not resistant to all chemicals. Do not immerse the instrument in solutions of strong acids, strong alkalis, etc., or wipe the instrument with such solutions.



CAUTION

Do not use abrasive powder or other polishing agents to wipe the instrument.

■ How to replace batteries

If  is displayed on the meter, the battery is low. Replace it with a new one as soon as possible (section 2.1).

When BATT LOW is displayed, the power turns off immediately.



CAUTION

When replacing batteries, do not mix new and old batteries or two different types of batteries.

7.3 Sensor Maintenance

This section describes general care and storage instructions for conductivity sensors.

■ How to clean the electrodes

Contamination adhering to the electrode area affects the cell constants, impairing accurate measurement.

Immediately after measurement, wash the electrode with clean water (e.g. tap water) to remove any adhering contaminant.

Even if the sensor appears clean, chemical contamination might impair sensitivity.

To remove this contamination, soak the tip in dilute hydrochloric acid solution (about 0.1 mol/L) or neutral detergent diluted in water and shake the electrode up and down. After cleaning, rinse off the cleaning solution with water.

For hard-to-remove contaminants on the electrode element of general-purpose type sensors and high purity water measurement sensors, use a cotton swab to gently remove the contaminants.

• Sensor for high purity water measurement

Remove the outer electrode section and clean the electrode element (shaded area) with a cotton swab or similar tool to ensure that there are no adhering contaminants.

If a neutral detergent is used, rinse well with water, and then wipe the electrode element (shaded area) well with tissue paper or a degreasing cotton ball.

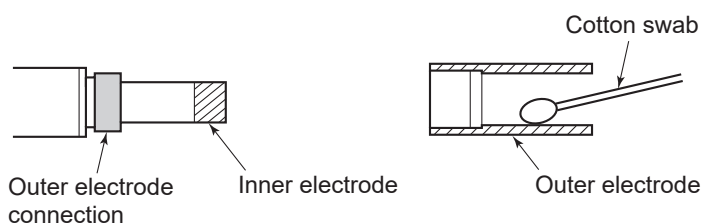

Figure 7.1 Sensor for high purity water measurement

• General-purpose type sensor

Remove the cover and clean the electrode element with a cotton swab or similar tool to ensure that there are no adhering contaminants.

Rinse well with water, especially when using neutral detergent, etc., and wipe the electrode element well with tissue paper or a degreasing cotton pad.

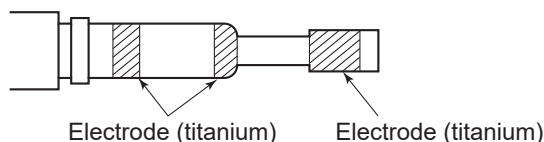

Figure 7.2 Sensor for general-purpose type

For chemical-resistant type sensors and sensors for high conductivity measurement, simply fill a beaker or other container with water, dilute hydrochloric acid solution, diluted neutral detergent, etc., immerse the sensor body up to the bubble outlet and let it rise and fall, or pour tap water, etc. through the bubble outlet.

CAUTION

Do not apply physical shock or excessive force to the glass sensor, or it may break.

Particularly, do not rub the glass membrane hard. It may damage or break the glass membrane.

8. Trouble Shooting

If the temperature measurement value is stable but the conductivity measurement value does not stabilize easily or shows an abnormal value, or if an error message is displayed, the followings are the three main causes of these problems.

- Consumables have reached their expiration date.
- Insufficient maintenance. Or not handled correctly.
- A malfunction has occurred.

If an error occurs, read this chapter to find the cause and take appropriate measures. Contact us for any malfunctions that cannot be resolved by this chapter.

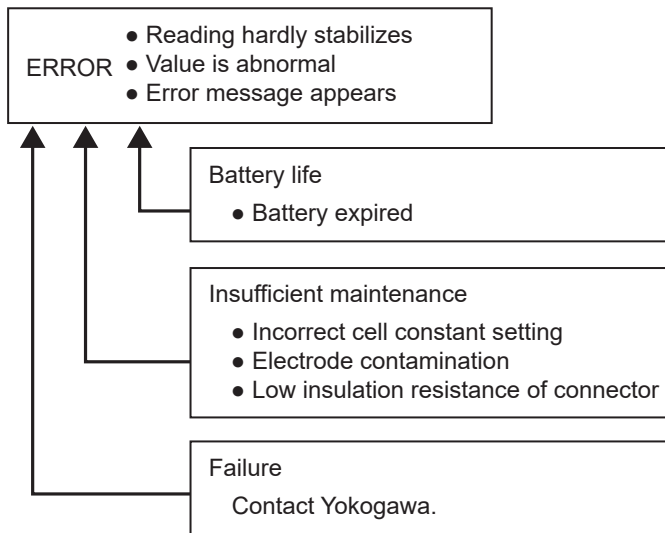

Figure 8.1 Causes of abnormalities

■ Error messages

If an error listed below appears during use, check the remedies in Table 8.1.

Table 8.1 Error messages

Meter display	Cause of error, How to solve the problem
BATT LOW	Battery power is low. Please replace with new batteries. (Section 2.1)
Std ERR	The conductivity factor (C.F) is out of the standard range. Clean the sensor (electrode), erase the calibration data (Section 4.1.6), and perform the calibration again. If the error persists, replace the sensor with a new one. When performing the manual calibration, Std ERR is not displayed.
	The standard solution cannot be automatically identified. Erase calibration data (Section 4.1.6), check the calibration solution, and use a new one if necessary. When performing the manual calibration, Std ERR is not displayed.
MEM FULL	The number of stored data exceeded 500. Delete the saved data (Section 4.2.2).
Ur, Or	The measured value is outside the measurement range (Table 8.2)
NOT STBL	The ENT ● key was pressed before the calibration value stabilized. Wait for the value to be stable and then press the ENT ● key. [ERR] also appears.
[ERR]	Indicates invalid operation was done.

Other trouble shooting

Table 8.2 shows common problems, their causes, and remedies.

Table 8.2 Other troubles

Troubles	Probable causes	How to solve problem
Measured values are unstable.	Sensor is not connected properly	Connect the sensor correctly.
	Electrode is not properly immersed in the measuring solution.	Immerse the sensor so that the liquid level comes up to the air bubble outlet.
	Air bubble at the electrode element	Shake the sensor to remove air bubbles.
	Sensor is broken.	Replace the sensor.
	Sensor is dirty.	Clean the sensor (Section 7.3)
The response is slow	There is an external induction motor nearby.	Conduct the measurement in a location that is not affected by external induction. Ground all equipment connected to the AC power source.
	Sensor is dirty.	Clean the sensor. (Section 7.3)
The response is slow	Sensor is broken.	Replace the sensor.
	Hold state.	Press the MEAS  key to release the hold state.
No change in measured value. No response	Sensor is not connected properly.	Connect the sensor correctly.
	Sensor is broken.	Replace the sensor.
	Instrument defect	Contact YOKOGAWA.
	Sample is out of the measurement range.	Use a sample within the measurement range.
The measured value is out of the measurement range*1	Sensor cable is disconnected.	Replace the sensor.
	Cell constant is not set.	Set cell constant.
	Uncalibrated or incorrectly calibrated	After clearing the calibration value, please perform the calibration correctly.
	Instrument defect	Contact YOKOGAWA.
	Repeatability of the measured value is poor.	Effect of the sample solution.
Effect of temperature		Differences in temperature between calibration and measurement will cause measurement errors.
Sensor is dirty.		Clean the sensor (Section 7.3)
Sensor is broken.		Replace the sensor.
Nothing appears when power is turned on	Power is not supplied.	Insert batteries.
	Battery polarity (+, -) is reversed.	Insert the batteries with the polarity (+, -) correctly oriented.
	Battery level is low	Replace the batteries.
	Instrument defect	Contact YOKOGAWA.
Part of the display is missing.	Instrument defect	Check the display by switching ON the instrument when all the LCD segments are lit.

*1 "Ur" is displayed when the measured value is below the display range.
 "Or" is displayed if the measured value exceeds the display range.

Revision Record

- Manual Title : SC92 Portable Conductivity Meter
- Manual No. : IM 12D03E02-02EN

Dec. 2024/2nd Edition

Compliant with KC marking product (pages v, vii)

Aug. 2024/1st Edition

Newly published

Yokogawa Electric Corporation
2-9-32 Nakacho, Musashino-shi, Tokyo 180-8750, JAPAN
<http://www.yokogawa.com/>



